



## Air Springs America 2022

Product Range | Gama de productos





# Contents | Índice

06 Introduction | Introducción

---

19 Product Overview | Listado de Productos

---

31 Rolling Lobe Air Springs | Bolsas de Aire Automotrices



215 Single Convoluted Air Springs | Bolsas de Aire de Una Cámara



221 Double Convoluted Air Springs | Bolsas de Aire de Dos Cámaras



265 Triple Convoluted Air Springs | Bolsas de Aire de Tres Cámaras



285 Sleeve Type Air Springs | Bolsas de Aire para Cabina y Asientos



309 Cross-reference | Referencias Cruzadas



310 Firestone > Continental

317 Firestone bellows > Continental

324 Goodyear > Continental

330 Goodyear bellows > Continental

---

337 Fitment Guide | Lista de Aplicaciones

























Manufacturer > Continental | Fabricante > Continental





# New | Nuevo

new

OE	OE #	CT	No.	 	 	
SAF Holland	90557290	AS 9 10SW-14 S 1574 CT	600932			107
Hendrickson	10214	FD 200-22A 908 CT	600929			240
		AS FT 430-35 1298	601025			275
		AS 9 10-21 P 1581 CT	601035			166
American Carrier	8003-023	9 9-12 P 1476 CT	79614			55
		AS 9 10-14 A 959 CT	601421			104
Freightliner	A16-21557-000	AS 9 10S-16 P 1600 CT	601538			122
Hendrickson	3318	AS FD 200-19A 730 CT	70120			238
Hendrickson	10343	AS FT 330-29 821 CT	70123			273
Reyco	702614-01	AS 9 10-16 P 1602 CT	601539			119
		AS 9 9L-10 P 1594 CT	601536			47
Tuthill	705951-01	AS 10 10-13 S 1614 CT	601634			168
Link	1101-0030	SC 29-P116 CT	601575			296
Kenworth	C81-1013	AS 9 10-19 P 1617 CT	601784			160
Freightliner	A16-20121-000	9 10S-16 P 1631	601986			123
Freightliner	A16-21556-000	9 10S-16 P 1634	601989			123
SAF Holland	90557213	9 10-17.5 P 573	70335			134
		11 10.5-21 A 1339	78046			208

# Introduction | Introducción

## **Continental Air Spring Systems - Maximum safety, maximum cost-efficiency, maximum comfort**

With components and constructions for self-regulating air springs, Continental Air Spring Systems is the development partner for O.E.M. supplied air spring assemblies to the commercial vehicle marketplace since 1955.

Continental, while the market leader within Europe, has worldwide representation in all key markets. Continental supplies these worldwide markets from various production sites in Europe, North America and Asia.

Continental maintains strategic alliances and an international sales network throughout the globe. Continental is recognized for the quality, reliability and long service life of its air springs and can provide the most cost-effective solutions that lead the way toward improved driving safety and comfort levels of all air suspended commercial vehicles.

### **The 'vital' advantages:**

- › Greater riding comfort resulting from low natural Frequency of air ride
- › Consistently superior suspension performance Resulting from load independent natural frequency
- › Consistent vehicle height resulting from a permanently Active height level control system.

This Continental air springs replacement guide for commercial vehicles presents a complete line of air spring assemblies for applications within the North American marketplace.

### **Contained within the Continental manual:**

- › Cross reference to competitor's designs
- › Direct O.E.M. cross reference
- › Suspension manufacturer's cross reference
- › Air spring assembly drawings
- › Technical data for each assembly

## **Continental Air Spring Systems - Máxima seguridad, máxima relación costo-eficiencia, máximo confort**

Con componentes y construcciones para bolsas de aire auto-regulables, Continental Air Spring Systems es socio en el desarrollo de sistemas de bolsas de aire para fabricantes de equipo original (O.E.M.) en el mercado de vehículos comerciales desde 1955.

Continental es el líder de mercado en Europa y está presente en los mercados más importantes a nivel mundial. Continental provee a estos mercados mundiales desde varios sitios de producción en Europa, Norte América y Asia. Continental mantiene alianzas estratégicas y una red de ventas internacionales en todo el mundo. Continental es reconocido por su calidad, confiabilidad y el largo periodo de vida de sus bolsas de aire y puede ofrecer las mejores soluciones con la mejor relación costo-eficiencia que son orientadas a ofrecer mayor seguridad y mayor nivel de confort en el manejo de todos los vehículos comerciales equipados con bolsas de aire.

### **Las ventajas 'vitales':**

- › Más confort en el manejo como resultado de la baja frecuencia natural de las suspensiones de aire
- › Desempeño consistentemente superior de la suspensión resultado de la frecuencia natural independientemente de la carga
- › Altura de vehículo constante debido a un sistema activo de control de nivel de altura

Esta guía de reemplazos de bolsa de aire Continental para vehículos comerciales presenta una gama completa de ensambles de bolsas de aire para aplicaciones del mercado Norte Americano.

### **El manual Continental contiene:**

- › Referencia cruzada con los modelos de la competencia
- › Referencia cruzada con fabricantes de vehículos O.E.M.
- › Referencia cruzada con fabricantes de suspensiones
- › Dibujos de ensambles de bolsas de aire
- › Datos técnicos para cada ensamble



## Engineering and product testing

Continental Air Spring Systems is one of the world's largest air spring manufacturers. Continental has been developing diverse solutions to meet our global customer's needs and requirements for over five decades. From this experience, Continental now offers the world's largest range of air springs. Continental's unique test facilities can simulate every suspension kinematics, plus cover all the significantly relevant force and frequency data developed in operational testing. The Continental durability tests can simulate the full service life of any commercial vehicle. Together with the results obtained in test drives, this enables Continental to supply reliable performance data on all suspension properties.

### The advantage

Sources of potential faults are continuously minimized.

## Production

The best product quality and maximum flexibility in responding to changing marketplace demands is ensured by Continental's State of the Art factories, which all work according to the same international quality standards. All production sites are certified according to IATF 16949, ISO 14001, ISO 9001.

### The advantage

Efficient production and a high degree of product availability.

## Customer Service

We nurture strong market ties by means of an ongoing dialog with all of our customers. Via our online product database [www.airspringapp.com](http://www.airspringapp.com), customers and dealers can directly obtain technical key data such as, drawings, cross references and corresponding OE part numbers for the complete Continental line of air springs.



## Ingeniería y pruebas de producto

Continental Air Spring Systems es uno de los más grandes fabricantes de bolsas de aire en el mundo. Continental ha estado desarrollado diversas soluciones para cubrir las necesidades de nuestros clientes globales durante cinco décadas. De esta experiencia, Continental ofrece la más grande gama de bolsas de aire en todo el mundo. Las instalaciones de prueba de Continental pueden simular la cinemática de cada suspensión, además de cubrir todos los datos relevantes de fuerza y frecuencia desarrollado en prueba de operación. Las pruebas de duración de Continental pueden simular la vida completa de servicio de cualquier vehículo comercial. Combinado con los resultados obtenidos en pruebas de manejo esto permite a Continental ofrecer datos confiables de las propiedades de operación de toda la suspensión.

### La ventaja

Fuentes potenciales de posibles fallas son disminuidos continuamente.

## La producción

La mejor calidad de productos y la máxima flexibilidad para responder a las demandas cambiantes de mercados está asegurado por las fabricas de ultima tecnología Continental las cuales trabajan según los mismos estándares internacionales de calidad. Todas plantas están certificadas según IATF 16949, ISO 14001, ISO 9001.

### La ventaja

Producción eficiente y alto nivel de productividad disponible.

## Servicio al cliente

Establecemos fuertes lazos con todos nuestros clientes a través de un dialogo continuo. A través de nuestro catalogo en línea [www.airspringapp.com](http://www.airspringapp.com), clientes, distribuidores y usuarios finales pueden obtener directamente información sobre nuestros productos como por ejemplo: dibujos, y datos técnicos importantes de toda la línea de Bolsas de Aire Continental.



# On the Road Worldwide | Alrededor del mundo

## Continental air spring systems for commercial vehicle applications.

### Air suspension for commercial vehicles

Air springs prove extremely successful in commercial vehicles of all kinds. They offer the most diverse possibilities for the front, rear and trailing axles as well as on the leading axle of semi-trailer tractors.

### Air suspension systems in buses

Nowadays, buses generally take advantage of air springs to ensure consistently high riding comfort and a constant boarding height regardless of the load. As a rule, two air springs are used on the front axle and four air springs on the rear axle. Newer "kneeling" buses are equipped with air springs that lower one side of the vehicle at stops, assisting passenger access.

### Cab suspension systems

Truck cabs and seats can be cushioned with air springs to enhance driver comfort, safety and working environment. Depending upon the design of the vehicle, the air spring is employed either as a separate suspension element alongside a shock absorber or combined as an integrated air spring / damper unit. In most cases, however, aftermarket demands are taken care of by the vehicle manufacturers themselves.

### Trailers/semi-trailers

Modern trailer and semi trailer are to a very great extent equipped with air suspension in order to save goods and vehicles and in order to provide more safety regarding road behavior of the vehicle. Normally, every axle assembly has two air springs behind the axle - one on each side. Where several axles are combined, one axle is often equipped with an axle lift device (lift or tag axle) to conserve the tires when the vehicle runs empty. Air springs exhibit high load carrying capacities with generous spring travel in these applications.

## Aplicaciones Continental para vehículos comerciales con suspensión neumática.

### Suspensión neumática para vehículos comerciales

Las bolsas de aire han tenido un éxito total y absoluto en todo tipo de vehículos comerciales. Estas ofrecen las más diversas posibilidades para los ejes frontal, trasero y el eje retráctil de semi-remolques.

### Sistema de suspensión neumática en autobuses

En la actualidad, los autobuses toman las ventajas de la suspensión neumática para asegurar una altura constante de confort y una altura constante no importando la carga del vehículo. Los más modernos autobuses están equipados con un sistema de bolsas de aire que permite bajar la altura del vehículo en la puerta cuando el vehículo esta parado para facilitar a los pasajeros el ascenso y descenso del mismo.

### Sistemas de suspensión para cabinas

Las cabinas y asientos de camiones pueden tener suspensión con bolsas de aire para mejorar el confort, seguridad y ambiente de trabajo del conductor. Dependiendo del diseño de vehículo, las bolsas de aire son usadas también como un elemento independiente de suspensión junto a un amortiguador de vibración o combinado como una unidad integral bolsas de aire / amortiguador.

### Remolques/Semi-remolques

Los remolques y semi-remolques modernos están equipados con un sofisticado equipo de suspensión neumática la cual ayuda entre otras cosas a proteger las mercancías transportadas, proteger el mismo vehículo, provee mayor seguridad respecto del comportamiento del vehículo en carretera. Donde se aplican varios ejes, frecuentemente uno de ellos esta equipado con un mecanismo de levante, este eleva el eje para que las ruedas queden suspendidas en el vehículo y esto permite conservar las llantas cuando el vehículo transita vacío. Las bolsas de aire permiten una alta capacidad de carga con generosas carreras de operación en estas aplicaciones.



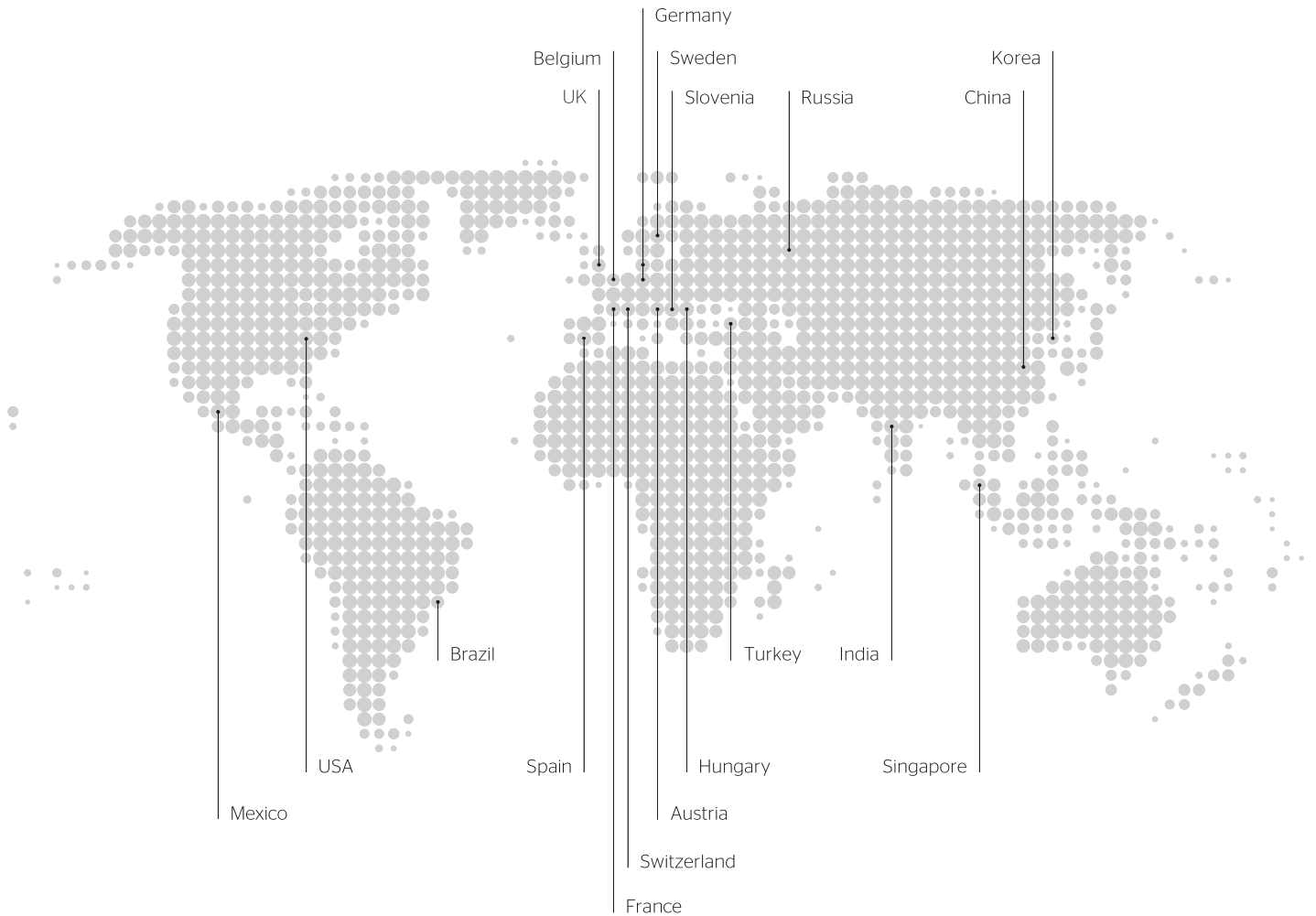

**Continental is present throughout the world with development, manufacturing, distribution and services geared to our customers’ needs.**

Continental’s follow the customer strategy is supported by our global presence in all major markets. Continental Air Spring Systems operates production and development centers in Germany (Headquarters), Turkey, Hungary, South Korea, China and Mexico as well as a worldwide distribution network. We see globalization as the continuous expansion of our capacities to make sure our products are available just-in-time wherever they are needed. Continental’s presence in North America is particularly supported by a state of the art air spring factory in San Luis Potosi, Mexico and sales offices and distribution centers throughout the United States.

**“Follow the customer” (Seguir al cliente) - tomando esta frase como nuestra estrategia mundial de expansión y atención, hemos creado plantas de producción, manufactura e investigación y desarrollo.**

Hannover representa nuestra matriz y centro de producción y atención para toda Europa, México representa nuestro centro de producción y atención para todo el mercado del continente Americano, Turquía representa nuestro punto de producción y atención para el mercado de Europa del Este y Medio Oriente, China y Korea representan nuestros puntos de producción y atención para el mercado Asiático y Oceanía. Todas ellas con sus correspondientes centros propios de distribución lo que nos proporciona una importante red internacional de ventas de Continental. Además cada planta participa de manera continua y novedosa en cada una de las ferias y expos más importantes de su región. Entendemos globalización como una expansión continúa de nuestras capacidades para asegurar que nuestros productos estén disponibles justo-a-tiempo donde quiera que sean necesarios. Continental desarrolla y produce la más avanzada tecnología en bolsas de aire para cualquier tipo de suspensión neumática, esta presente en el camino, en las vías y en la industria.

# Product Information | Información del producto

**1** 9 10S-18 P 1067 (BK) new

**2**

**3** 3746 **4**

**5** 12,6 lb **6** 9316239 **7** B19.5 P 889

**Cross-reference | Cruce de Referencia**

**8** Firestone No. W01-358-1191  
W01-358-9875  
Goodyear 1R12-432

**Manufacturer | Fabricante**

**9** Avistar/Fleetrite 350243C94  
3541731C1

**10** M12x1.75: max. 30 lb-ft  
1/4-18 NPTF: max. 22 lb-ft

- |   |  |
|---|--|
| <ol style="list-style-type: none"> <li>1. Continental part no.</li> <li>2. Cross section / top view / bottom view</li> <li>3. Continental order no.</li> <li>4. Application</li> <li>5. Weight</li> <li>6. Piston no.</li> <li>7. Replaces</li> <li>8. Cross-reference:<br/>Firestone or Goodyear part no.</li> <li>9. Manufacturer part no.</li> <li>10. Recommended torque</li> </ol> | <ol style="list-style-type: none"> <li>1. No. de parte Continental</li> <li>2. Vista de la sección transversal / superior / inferior</li> <li>3. No. de orden Continental</li> <li>4. Aplicación</li> <li>5. Peso</li> <li>6. No. de pistón</li> <li>7. Reemplazo</li> <li>8. Cruce de referencia:<br/>No. de parte Firestone o Goodyear</li> <li>9. No. de parte de fabricante</li> <li>10. Par de apriete recomendado</li> </ol> |
|---|--|

## Service | Servicio

Service for our partners | Servicio para nuestros socios

Services | Servicios:

- > News | Noticias
- > Services | Servicios
- > Products | Productos
- > Promotion | Promoción

Websites | Páginas web

- [www.airspringreplacement.com](http://www.airspringreplacement.com)
- [www.continental-industry.com](http://www.continental-industry.com)
- [www.continental-aftermarket.com](http://www.continental-aftermarket.com)



# Components | Componentes

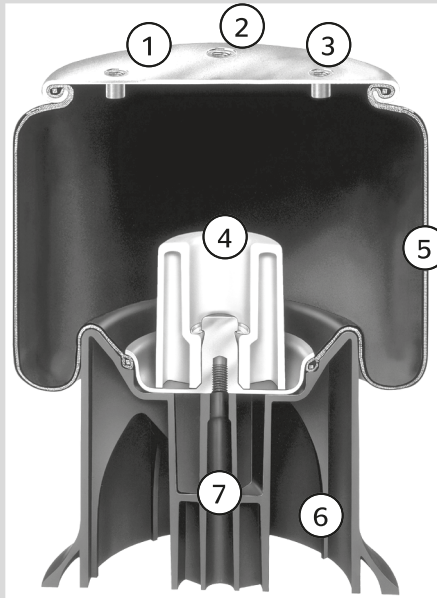

**Rolling lobe air springs** | Bolsas de Aire Automotriz

1. Top/bottom plate
2. Air inlet
3. Bolts or blind nuts
4. Bumper
5. Rolling lobe
6. Piston (steel or plastic)
7. Bump stop



**Convoluted air springs** | Bolsas de Aire de Cámaras

1. Plato superior/inferior
2. Entrada de aire
3. Perno con rosca o agujeros ciegos
4. Tope
5. Fuelle
6. Pistón (acero o plástico)
7. Soporte de tope
8. Fuelle de cámaras

# Online Catalogue | Catálogo en línea

Service for our partners | Servicio para nuestros socios

## Services | Servicios:

- > **Product Information** | Información sobre el producto
- > **Cross-Reference** | Referencias cruzadas
- > **Technical Drawing** | Dibujo técnico
- > **Fitment Guide** | Guía de ajuste

## Features | Características:

- > **Combining catalogue and app** | Combinación de catálogo y app
- > **European and American product range just one click apart** | Gama de productos europeos y americanos a un clic de distancia
- > **Product pictures** | Imágenes de los productos
- > **Comparison function** | Función de comparación

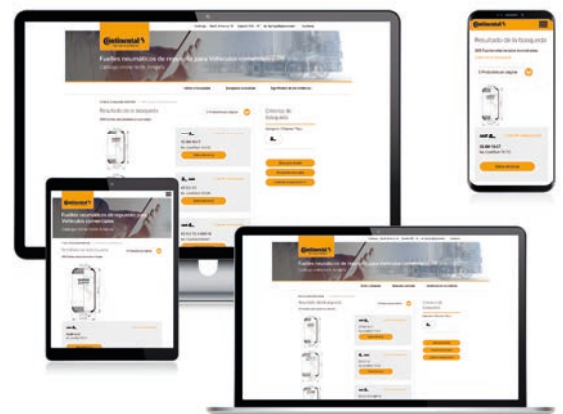

EN



ES

[www.airspringapp.com](http://www.airspringapp.com)

# General Information | Información general

Standard labels | Etiquetas estándar



## Warning

### Air spring construction

Continental air springs are specifically designed to meet the customers' needs in terms of carrying capacity, spring characteristics, spring deflection and space requirements among others. Continental air springs are made of high quality elastomer materials that have been developed, tested and proven throughout Continental's 135 year experience in the rubber industry.

The excellent dynamic behavior of Continental's elastomer materials combined with high performance plastic and metal components result in a maintenance free long service life of our air spring systems. To assure a trouble free operation we recommend the following:

### Warning

- Do not inflate the air spring unless it is properly secured in an appropriate structure.
- Operate the air spring only in the vehicle's suspension system or a suitable device.
- Do not allow the pressure to exceed 100 psi / 7 bar. Otherwise there is a risk of injury!
- Maintain a service temperature of max -40 °C (-44 °F) to 70 °C (154 °F)

### Preventive Maintenance

- Check clearance of complete circumference of the air spring to avoid contact between bellow and other vehicle parts.
- Check the torque of mounting fittings - do not over torque (see warning label for torque recommendations)

- Maintain components of pneumatic system as valves, regulators and lines clean and in good shape.
- Make sure appropriate shock absorbers are installed and in good condition. The shock absorber will limit the maximum rebound of an air spring and keep it from overextending.
- Keep the air springs clean (to wash use soap and water)
- Do not apply cleaning media based on mineral, hydraulic or lubricant oils, organic solvents, abrasives or open flames.

### Storage

Continental air springs should be kept in dark, dry storage at normal room temperature.



## Precaución

### Construcción de las bolsas de aire

Las bolsas de aire Continental son desarrolladas para proveer las propiedades demandadas en cada caso particular como la capacidad de carga, características de amortiguamiento y características de deflexión. Las bolsas de aire Continental son fabricadas con materiales elastómeros de alta calidad los cuales son insensibles a las influencias atmosféricas así como al ozono.

El excelente comportamiento dinámico de los materiales del elastómero resulta en una vida útil larga en las bolsas de aire Continental. Para asegurar una operación sin problemas recomendamos lo siguiente.

### Precaución

- No inflar a menos que esta completamente asegurada en una estructura adecuada.
- Operar la bolsa de aire solo en el sistema de la suspensión del vehículo o cualquier otra estructura adecuada a la altura de diseño.
- No permitir que la presión suba a más de 100 psi/7 bar. De lo contrario hay riesgo de lesión.
- Mantenga la temperatura de servicio de máx. -40 °C a 70 °C

### Inspección continúa

- Evite contacto entre la membrana y otras partes del vehículo.
- Revise el torque de los montajes - no los atorille demasiado (vea etiqueta de advertencia).
- Mantenga los componentes del sistema neu-

mático como válvulas, reguladores así como las líneas de aire limpios y en buen estado.

- Asegurarse de tener los amortiguadores apropiados. El amortiguador normalmente limitará la carrera máxima de una bolsa de aire y así no permitirá que se sobre extienda.
- Mantenga las bolsas de aire limpias (para lavado use agua y jabón).
- No aplicar limpiadores a base de aceites minerales, solventes, aceites hidráulicos, grasas lubricantes.

### Almacenamiento

Las bolsas de aire Continental deben permanecer almacenados en un lugar oscuro y seco a temperatura ambiente.

# Problem and Cause | Problema y causa

## Main causes for premature air spring failures - and how to prevent them

Principales Causas de Fallas prematuras en Bolsas de Aire y cómo prevenirlas



### Overtorque | Sobretorque

#### Cause of Failure | Causa de falla

Fittings can break or threads be damaged caused by over-torque. (Note: grease or lubrication on the threads can affect the torque and may cause damages) The Air spring system can be twisted.

Los montajes se pueden romper o las roscas se pueden dañar debido a sobretorque. (Nota: Aceites o lubricantes en las roscas puede afectar el torque y puede causar daños). Las bolsas de aire se pueden torcer lo cual reduce la vida útil de la membrana de manera considerable.

#### Recommendation | Recomendación

Apply general installation instructions. Review drawing or product warning label for proper assembly torque. Do not use an air wrench for installation.

Siga las instrucciones generales de instalación. Revise el dibujo o la etiqueta de advertencia del producto para aplicar un torque correcto. No use pistola de aire para la instalación.

### Overextension | Sobre extensión

#### Cause of Failure | Causa de falla

The air spring is operated outside the maximum rebound range as a result of unrestrained (missing end stop) or excessive axle travel (defective/improperly adjusted height levelling system or wrong air spring). The abuse may result in separation of the bellows from upper or lower mounting parts.

La bolsa de aire está operando fuera de la máxima altura recomendada como resultado de una carrera no restringida o excesiva del brazo de la suspensión (sistema de nivel defectuoso/impropio, o bolsa de aire incorrecta). El abuso de la carrera puede resultar en la separación de la membrana de las partes de montaje.

#### Recommendation | Recomendación

Check and/or adjust height levelling system, shocks, end stops and air spring specifications to prevent air spring travel of exceeding the max. recommended height.

Pruebe y/o ajuste el sistema de nivel de altura, verifique los amortiguadores de impacto, restrictores de carrera y especificaciones de la bolsa de aire para prevenir que la carrera de amortiguamiento no exceda la altura máxima.

# Problem and Cause | Problema y causa

## Main causes for premature air spring failures - and how to prevent them

Principales Causas de Fallas prematuras en Bolsas de Aire y cómo prevenirlas



### Abrasion | Abrasión

#### Cause of Premature Failure | Causa de falla

Bellows in contact with other components (e.g. defective parts) of the vehicle or foreign objects (e.g. dirt, rocks) that accumulate at the piston/ rolling part of the bellows. They may rub through the bellows during spring deflection.

La membrana tiene contacto con otros componentes del vehículo (Ej. Llantas, amortiguadores de impacto) u otros objetos extraños (ej. piedras o vidrios incrustados en el pistón) los cuales friccionan con la membrana y/o el pistón durante la carrera de operación.

#### Recommendation | Recomendación

Avoid contact between bellows and any other part of the vehicle. Check air springs periodically / remove foreign objects from the rolling part of bellows. (Warning: Do not use solvents for washing)

Evite contacto entre la membrana y otras partes del vehículo. Verifique el estado de las bolsas de aire periódicamente / quite objetos extraños adheridos o incrustados al pistón o a la membrana. (Advertencia: No use solventes para lavado)

### Overload | Sobrecarga

#### Cause of Failure | Causa de falla

When overloading the vehicle the height levelling valve will open to adjust vehicle height by increasing the pressure inside the air spring up to max. system pressure available. The improper usage of the air spring system outside the recommended pressure range may cause deformation or damage to the bellows, piston and/or bead plate.

Cuando un vehículo es sobrecargado la válvula de nivel de altura va a abrir para ajustar la altura del vehículo subiendo la presión dentro de la bolsa de aire al máximo de la presión disponible del sistema. El uso inadecuado de la bolsa de aire fuera del rango de presión recomendable podría causar daño a las bolsas, pistones y/o platos.

#### Recommendation | Recomendación

Avoid overloading of the vehicle. Check air spring specifications for max. load capacity.

Evite sobrecargar el vehículo. Verifique la capacidad máxima de carga y/o en las especificaciones de la bolsa de aire.

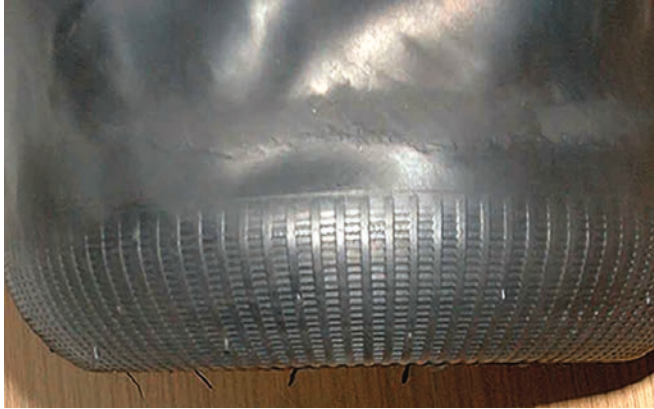

## Contamination | Contaminación

### Cause of Failure | Causa de falla

Air spring bellows are not resistant to solvents, hydraulic oils nor lubricants. A permanent exposure to chemicals will cause premature failure of air spring system.

La membrana de las bolsa de aire no es resistente a solventes, aceites hidráulicos ni lubricantes. El contacto permanente con productos químicos va a causar fallas prematuras a las bolsas de aire.

### Recommendation | Recomendación

Check the air spring system periodically. Avoid too much oil in the air supply lines. Remove lubricants from the bellows. Do not use mineral oil based cleaners. Do not use any solvents.

Verifique las bolsas de aire periódicamente. Evite el flujo de aceite a través de las líneas de suministro de aire. Retire el lubricante que se adhiera a la membrana. No use limpiadores a base de aceites minerales. No use ningún solvente.



## Low pressure | Presión baja

### Cause of Premature Failure | Causa de falla

When operating the air spring system without internal air pressure, it prevents the bellows from rolling uniformly over the piston/girdle hoop, instead it may fold. Permanent operation without internal air pressure will increase wear of the bellows significantly.

Operación de la bolsa de aire sin presión interna de aire permite que la membrana adopte formas uniformes sobre el pistón y/o arillo intermedio, en vez de mantenerse lisa se mantiene con pliegues. Esta condición de operación por largos periodos de tiempo reduce la vida útil de la membrana de lasbolsas de aire de manera considerable.

### Recommendation | Recomendación

Avoid operating air spring system without internal air pressure. (Inflate air springs before driving) Check periodically the air supply lines for leaks. Examine the bellows for development of folds.

Evite operar la bolsa de aire sin presión interna de aire. (Infla la bolsa de aire antes de manejar) Revise periódicamente las líneas de suministro de aire para verificar que no haya fugas de aire. Examine las membranas de las bolsas para ver que no tienen pliegues marcados.

# Identification System | Sistema de identificación

## Rolling Lobe Air Spring | Bolsas de Aire Automotriz

Rolling lobe type air springs consist of the rubber bellows, bead plate, piston, and an optional internal bumper. Rolling lobe air springs provide the maximum ride comfort and therefore are the most popular air spring designs for commercial vehicle suspensions.

Las Bolsas de Aire Automotrices consisten de una membrana de goma, un plato superior y un pistón. Las Bolsas de Aire Automotriz proveen el máximo confort al circular y por lo tanto son el diseño de bolsas de aire más populares para aplicaciones en suspensiones de vehículos comerciales.

9 10 (XX)-16 P 310

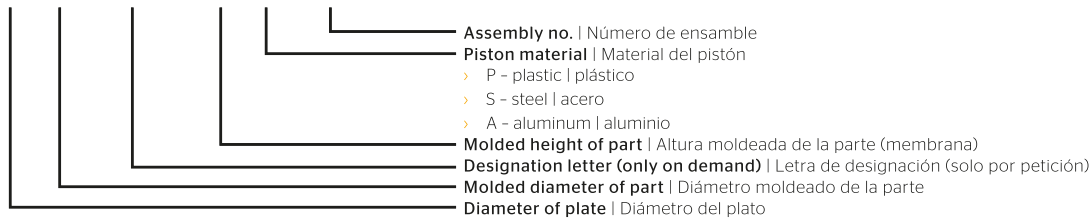

## Convuluted Air Spring | Bolsas de Aire de Cámaras

Convuluted type air springs consist of the rubber bellows, top and bottom bead plate, and an optional internal bumper. Convuluted air springs are used in both Vehicular suspensions and Industrial applications. In industrial applications, they are used as air actuators or vibration isolators.

Las Bolsas de aire de cámaras consisten de una membrana de goma, un plato superior y un plato inferior. Las bolsas de aire de cámaras son también ampliamente usadas en aplicaciones industriales como actuadores neumáticos y aisladores de vibración.

FD 200-19 320

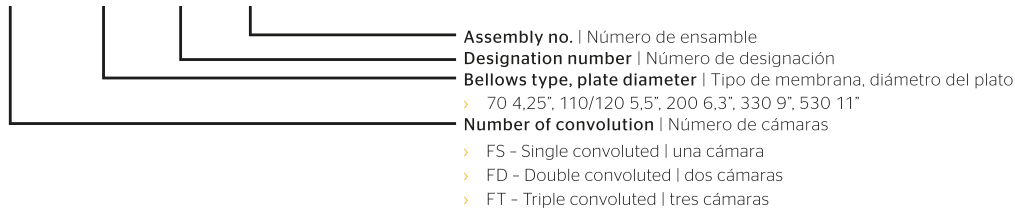

## Sleeve Type Air Springs | Bolsas de Aire tipo Manga

Sleeve type air springs consist of the rubber sleeve bellows, cap, piston, and an optional internal bumper. Sleeve type air springs provide the maximum ride comfort for cabin and driver seat suspensions as air actuators or vibration isolators.

Las Bolsas de aire tipo mangas consiste de una membrana de goma, un plato superior y un pistón. Las bolsas tipo manga proveen el máximo confort de manejo en la cabina y en el asiento del conductor.

SC 31-Y 215









# Product Overview

## Listado de Productos



No.	CT	2 3	
64245	FD 330-30 705	255	
64252	10 10-21 P 570	183	
64253	11 10.5-15 A 415	188	
64254	11 10.5C-16 A 320	191	
64255	9 9-12 P 314	48	
64256	9 9-12 P 515	51	
64258	9 10-14 P 345	94	
64259	9 10-16 P 408	113	
64260	9 10-10 P 311	70	
64262	9 10-16 P 407	113	
64265	9 10-18.5 P 519 (BK)	144	
64266	9 10S-16 A 382	120	
64267	FD 200-19 320	232	
64268	FD 330-22 331	246	
64269	9 10-16 P 310	108	
64270	FD 330-22 313	245	
64271	FD 200-19 319	231	
64272	11 10.5-17 A 317	197	
64273	11 10.5-21 A 313	206	
64274	9 10-14 P 312	93	
64275	9 10-16 P 409	114	
64276	9 10-16 P 410	114	
64278	9 10-17.5 P 429	129	
64279	9 10-19 P 315	150	
64280	9 10-19 P 321	150	
64281	9 10-19 P 383	153	
64283	FD 330-22 327	246	
64284	FD 331-26 480	256	
64285	FT 330-29 434	267	
64286	9 9-12 P 563	52	
64287	9 10-13.5 S 433	89	
64288	9 10-19 P 435	153	
64289	11 10.5-19 A 509	203	
64291	9 10-21 P 361	163	
64292	9 10-16 P 325	108	
64293	9 10-16 P 332	109	
64294	9 10-16 P 333	109	
64296	9 10-16 P 351	109	
64297	9 10-16 P 352	110	
64298	9 10-16 P 353	110	
64299	9 10-16 A 354	110	
64300	9 10-16 P 371	111	
64301	9 10-16 P 372	111	

No.	CT	2 3	
64302	9 10-16 P 376	111	
64304	9 10-16 P 391	112	
64305	9 10-16 P 392	112	
64306	9 10-16 P 393	112	
64307	9 10-16 P 394	113	
64308	9 10-16 P 441	115	
64314	9 10-16 P 497	115	
64315	9 10-16 P 498	115	
64317	9 10-16 P 500	116	
64318	9 10-16 P 510	116	
64323	9 10-19 P 326	150	
64324	9 10-19 P 355	151	
64325	9 10-19 P 356	151	
64326	9 10-19 P 357	151	
64327	9 10-19 A 358	152	
64328	9 10-19 P 359	152	
64331	9 10-19 P 390	153	
64334	9 10-17.5 P 418	128	
64335	9 10-19 P 438	154	
64338	9 10-19 P 470	154	
64339	9 10-19 P 472	155	
64340	9 10-19 P 552	155	
64341	9 10-19 P 553	156	
64342	11 10.5-17 A 316	196	
64343	11 10.5-17 A 364	197	
64344	11 10.5-17 A 365	197	
64346	11 10.5-17 A 367	198	
64347	11 10.5-17 A 377	198	
64348	11 10.5-17 A 388	199	
64349	11 10.5-17 A 405	199	
64350	11 10.5-17 A 507	199	
64351	11 10.5-17 A 556	200	
64352	11 10.5-21 A 318	206	
64354	11 10.5-21 A 370	207	
64356	11 10.5-21 A 558	207	
64357	11 10.5C-16 A 378	191	
64358	11 10.5C-16 A 380	192	
64359	11 10.5C-16 A 385	192	
64360	9 9-12 A 334	48	
64361	9 9-12 P 379	49	
64362	9 9-12 P 401	49	
64363	9 9-12 P 447	49	
64364	9 9-12 P 464	50	

No.	CT	2	3		
64365	9 9-12 P 477	50			
64366	9 9-12 P 478	50			
64367	9 9-12 P 479	51			
64368	9 9-12 P 516	51			
64369	9 9-12 P 524	52			
64371	9 10B-17.5 A 323	140			
64375	9 10D-21 A 324	166			
64376	9 10D-21 A 363	167			
64377	9 10D-21 A 555	167			
64378	9 9-14 P 322	60			
64379	9 9-14 A 337	60			
64381	9 9-14 P 517	60			
64382	9 10-21 P 360	162			
64383	9 10-21 P 448	163			
64384	9 10-21 P 505	164			
64385	9 10-21 P 511	164			
64386	9 9K-15 P 417	65			
64387	9 9K-15 P 423	65			
64388	9 9K-15 P 424	65			
64389	9 9K-15 P 425	66			
64390	9 9K-15 P 455	66			
64391	11 10.5-19 A 431	202			
64392	11 10.5-19 A 432	202			
64393	11 10.5-19 A 508	202			
64394	10 10-21 P 434	182			
64395	9 10-12 A 427	81			
64396	10 10-15 S 518	172			
64397	10 10-15 P 522	173			
64398	9 10-17.5 P 426	128			
64399	9 10-17.5 P 428	129			
64400	9 10-17.5 P 430	129			
64401	9 10-17.5 P 436	130			
64402	9 10-17.5 P 443	130			
64404	9 10-17.5 P 452	131			
64405	9 10-17.5 P 454	131			
64407	9 10-17.5 P 475	132			
64411	9 10-17.5 A 535	133			
64412	9 10-17.5 P 548	133			
64414	9 10-18.5 P 551	145			
64415	9 10-17.5 P 571	134			
64419	10 10-21 P 486	182			
64421	11 10.5A-16 P 523	190			
64422	11 10.5-22 A 530	209			

No.	CT	2	3		
64423	9 10-17.5 P 536	133			
64424	11 10.5-15 A 414	188			
64425	11 10.5-15 A 419	188			
64426	11 10.5-15 A 420	189			
64427	11 10.5-15 A 421	189			
64428	11 10.5-15 A 422	189			
64429	11 10.5-15 A 506	190			
64430	9 10-10 P 328	71			
64431	9 10-10 P 331	71			
64432	9 10-10 P 338	71			
64433	9 10-10 P 339	72			
64435	9 10-10 P 397	72			
64436	9 10-10 P 398	72			
64437	9 10-10 P 399	73			
64438	9 10-10 P 400	73			
64439	9 10-10 P 471	73			
64440	9 10-10 P 473	74			
64441	9 10-10 P 480	74			
64442	9 10-10 P 481	74			
64443	9 10-10 P 482	75			
64444	9 10-10 P 503	75			
64445	9 10-12 P 319	78			
64446	9 10-12 A 327	79			
64447	9 10-12 P 329	79			
64448	9 10-12 A 341	79			
64449	9 10-12 A 342	80			
64450	9 10-12 P 343	80			
64451	9 10-12 P 395	80			
64452	9 10-12 P 396	81			
64454	9 10-12 A 463	81			
64455	9 10-12 P 483	82			
64456	9 10-12 P 484	82			
64457	9 10-12 P 485	83			
64459	9 10-12 P 488	83			
64460	9 10-12 P 495	84			
64462	9 10-12 P 543	84			
64463	9 10-12 P 544	84			
64464	9 10-14 A 330	93			
64465	9 10-14 P 335	93			
64466	9 10-14 P 344	94			
64467	9 10-14 P 346	94			
64468	9 10-14 P 348	95			
64469	9 10-14 P 349	95			

Product Overview |  
Listado de Productos

No.	CT	2 3	
64470	9 10-14 P 381	96	
64471	9 10-14 P 437	96	
64472	9 10-14 P 450	96	
64473	9 10-14 P 461	97	
64474	9 10-14 P 462	97	
64477	9 10-14 P 469	98	
64478	9 10-14 P 489	98	
64479	9 10-14 P 490	98	
64480	9 10-14 A 491	99	
64482	9 10-14 P 493	99	
64483	9 10-14 P 494	100	
64484	9 10-14 A 496	100	
64486	9 10-14 A 545	101	
64487	9 10-14 A 546	101	
64488	FD 330-22 318	246	
64489	FD 330-22 334	247	
64490	FD 330-22 337	247	
64491	FD 330-22 343	247	
64492	FD 330-22 346	248	
64493	FD 330-22 363	248	
64494	FD 330-22 364	248	
64495	FD 330-22 365	249	
64496	FD 330-22 366	249	
64497	FD 330-22 367	249	
64498	FD 330-22 368	250	
64499	FD 330-22 471	250	
64500	FD 330-22 472	250	
64501	FD 330-22 500	251	
64502	FD 330-22 540	251	
64503	FT 530-32 325	276	
64504	FT 530-32 329	276	
64505	FT 530-32 333	276	
64506	FT 530-32 336	277	
64507	FT 530-32 535	277	
64508	FT 530-32 536	277	
64509	FD 200-19 310	231	
64510	FD 200-19 315	231	
64511	FD 200-19 362	232	
64512	FD 200-19 448	232	
64513	FD 200-19 450	233	
64514	FD 200-19 452	233	
64515	FD 200-19 499	233	
64516	FD 200-19 504	234	

No.	CT	2 3	
64517	FD 200-19 505	234	
64518	FD 200-19 506	234	
64519	FD 200-19 510	235	
64520	FD 200-19 539	235	
64521	FS 530-14 339	217	
64522	FS 530-14 361	217	
64523	FS 530-14 442	218	
64524	FS 530-14 446	218	
64525	FS 530-14 447	218	
64526	FS 530-14 515	219	
64527	FS 530-14 516	219	
64528	FS 530-14 517	219	
64529	FS 530-14 538	220	
64531	FD 330-30 323	252	
64532	FD 330-30 340	252	
64533	FD 330-30 369	252	
64534	FD 330-30 370	253	
64535	FD 330-30 371	253	
64536	FD 330-30 372	253	
64537	FD 330-30 373	254	
64539	FD 330-30 502	254	
64540	FD 330-30 512	254	
64541	FD 330-30 513	255	
64542	FD 330-30 549	255	
64543	FD 530-22 311	257	
64544	FD 530-22 316	257	
64545	FD 530-22 321	257	
64546	FD 530-22 342	258	
64547	FD 530-22 345	258	
64548	FD 530-22 374	258	
64549	FD 200-25 426	241	
64550	FD 200-25 427	241	
64551	FD 200-25 428	242	
64552	FD 200-25 429	242	
64553	FD 200-25 453	242	
64554	FD 200-25 454	243	
64555	FD 200-25 463	243	
64556	FD 200-25 507	243	
64557	FD 200-25 511	244	
64558	FD 200-22 529	239	
64560	FT 330-29 413	266	
64561	FT 330-29 430	266	
64562	FT 330-29 431	266	

No.	CT	2 3		
64563	FT 330-29 432	267		
64564	FT 330-29 433	267		
64565	FT 330-29 466	268		
64566	FT 330-29 469	268		
64567	FT 330-29 498	268		
64568	FT 330-29 503	269		
64570	FT 330-29 520	269		
64571	FT 330-29 525	269		
64572	FT 330-29 546	270		
64573	FT 330-29 547	270		
64574	FT 330-29 548	270		
64576	FT 530-35 436	278		
64577	FT 530-35 437	278		
64578	FT 530-35 438	279		
64579	FT 530-35 439	279		
64580	FT 530-35 441	279		
64581	FT 530-35 455	280		
64582	FT 530-35 456	280		
64583	FT 530-35 457	280		
64584	FT 530-35 521	281		
64585	FT 530-35 522	281		
64586	FT 530-35 523	281		
64587	FT 530-35 534	282		
64588	FT 530-35 537	282		
64589	FD 530-30 449	259		
64590	FD 530-30 451	259		
64591	FD 530-30 518	259		
64592	FD 530-30 519	260		
64593	FD 530-30 532	260		
64594	FS 330-11 467	216		
64595	FS 330-11 468	216		
64596	FS 330-11 474	216		
64597	FD 331-26 514	256		
64599	FD 331-26 541	256		
64601	FD 120-20 509	229		
64602	FD 200-22 524	239		
64604	FD 530-35 530	261		
64605	FD 530-35 543	261		
64606	FD 530-35 544	261		
64607	FD 530-35 545	262		
64615	9 10-19 P 358	152		
64621	9 10-14 PT75 (BK)	106		
64622	FD 200-25 721	244		

No.	CT	2 3		
64623	FD 530-35 720	262		
64624	10 10-15 P 453	172		
64625	10 10-14 S 736	169		
64627	9 9-12 P 705	52		
64628	11 10.5C-16 A 706	192		
64631	9 9-14 P 708	61		
64632	9 10-14 P 709	102		
64633	9 10-12 A 707	85		
64634	9 10-16 P 710	117		
64635	10 10-15 P 711	173		
64636	10 10-16 P 533	177		
64637	11 10.5-24 S 712	213		
64638	10 10-16 P 526	177		
64639	10 10-15 S 713	173		
64643	9 10-10 P 717	76		
64644	9 10-14 P 718 (BK)	102		
64645	10 10.5-15 P 460	185		
64646	9 10-12 P 720	85		
64648	FT 330-29 703	271		
64649	10 10-16 S 724	178		
64650	9 10-16 P 769	117		
64651	9 10-16 P 770	118		
64658	9 10-10 P 542	75		
64660	11 10.5C-16 A 729	193		
64664	9 9-12 P 730	53		
64665	FD 200-22 706	239		
64666	FD 120-20 715	230		
64667	9 10-13.5 S 734	89		
64668	9 10-17.5 P 731 (BK)	135		
64669	9 10-17.5 P 732 (BK)	135		
64670	9 10-17.5 P 733	136		
64676	FD 530-30 707	260		
64683	FD 200-23A 709	241		
64685	FD 200-19 712	235		
64688	11 10.5-22 S 750	210		
64689	11 10.5-16.5 A 751	194		
64690	11 10.5-22 A 752	210		
64692	9 9-16 P 568	68		
64693	9 10BP-16 P 569	120		
64694	9 10BP-20 P 738	162		
64695	9 10BP-22 P 739	167		
64696	9 9B-20 P 740	69		
64697	9 9B-22 P 741	69		

No.	CT	2 3	
64700	9 9-9 P 756	44	
64701	9 9-12 P 757	53	
64702	FD 200-25 717	244	
64707	11 10.5-13 A 761	187	
64708	9 10-19 P 762	156	
64709	FT 330-29 722	272	
64710	FT 330-29 723	272	
64711	9 10-19 P 765	156	
64712	FD 200-19 724	236	
64713	9 9-9 P 767	45	
64714	9 9-14 P 768	61	
64715	9 10-21 A 361	162	
64716	9 10-21 A 505	163	
64725	10 10-15 S 773	174	
64728	10 10-21 P 774	183	
64729	9 10-17.5 P 779	136	
64730	FD 70-15 733	222	
64731	FD 110-15 734	224	
64732	FD 110-15 735	225	
64733	FD 120-20 736	230	
64734	FD 110-15 737	225	
64735	FD 70-15 738	223	
64736	FD 110-15 739	225	
64737	FD 70-15 740	223	
64738	FD 110-15 741	226	
64739	FD 70-15 742 (4ply)	223	
64740	FD 110-15 743 (4ply)	226	
64741	FD 70-15 744 (4ply)	224	
64742	FD 110-15 745 (4ply)	226	
64743	FD 110-15 746 (4ply)	227	
64746	10 10-16.5 S 783	180	
64752	9 9-12 P 786	53	
64754	9 9K-12 P 790	56	
64756	9 10-17.5 P 793	136	
64761	9 10-19 A 552	155	
64762	9 10-17.5 A 802	137	
64767	9 10-17.5 P 807 (BK)	137	
65218	11 10.5F-17.5 P 800	200	
65356	9 10-19 P 439	154	
65358	11 10.5-17 A 368	198	
65359	9 10B-17.5 A 362	140	
65360	11 10.5-19 A 557	203	
65361	9 10-14 P 575	101	

No.	CT	2 3	
65364	9 10-14 P 347	95	
65368	11 10.5B-18 P 743	201	
65382	9 10-19 P 796	157	
65387	9 10-19.5 A 801	161	
65391	FD 110-15 758	227	
65396	9 10-19 P 809	157	
65520	9 10-19 P 814	157	
65537	9 10LP-17.5 P 815 (BK)	141	
65540	9 10LP-17.5 P 806 (BK)	141	
65593	11 10.5F-17 P 745	200	
65649	9 10-21 P 817	164	
65772	11 10.5-22 A 824	210	
65796	11 10.5F-17.5 P 829	201	
65807	9 10-19 A 830	158	
65828	FT 530-35 726	282	
65831	9 10-17.5 P 831	137	
65906	11 10.5C-16 A 834	193	
65908	9 9-12 P 835	54	
65912	9 10-14 P 825	103	
65978	FT 330-29 773	272	
65990	9 10-14 P 577	102	
66005	9 10-16 P 841	118	
66029	9 10-12 A 848	86	
66083	10 10-16.5 S 854	180	
66084	11 10.5-21 A 855	207	
66085	11 10.5-22 A 856	211	
66091	FS 330-11 771	217	
66092	FD 110-15 763	227	
66094	FD 110-15 766	228	
66117	9 10-12 P 839	86	
66141	5S 8-15.5 (644N)	32	
66300	FD 330-22 780	251	
66325	10 100-14 P 838	171	
66340	10 10-15 S 871	174	
66447	9 10-13.5 S 881	90	
66521	9 10-14 P 882	103	
66522	FT 330-29 554	271	
66660	FD 70-13 796	222	
66661	FD 120-20 795	230	
66662	FD 200-22 765	240	
66666	9 10-19 P 898	158	
66700	9 10-17.5 P 904	138	
66978	9 10-18.5 P 935 (BK)	146	



No.	CT	2	3		
67442	11 10.5CT-16 A 943	193			
67447	11 10.5A-16 P 934	191			
67448	9 9K-15 P 945 (BK)	66			
67449	9 10-14 P 875	103			
67450	9 10-16 P 876	118			
67452	SC31-W206	306			
67473	9 10S-16 P 382	121			
67479	9 10-19 P 946	159			
67480	9 10-19 A 946	159			
67490	9 10-10.5 P 883	76			
67491	9 10P-18.5 P 886	148			
67492	9 9-14 P 895	62			
67507	10 10-21 P 949	183			
67547	11 10.5-19 A 960	203			
67553	FD 110-17A 789	228			
67572	FT 530-35 808	283			
67573	9 10-18.5 P 939 (BK)	146			
67577	9 10-12 P 463	82			
67586	9 10-17.5 A 930	138			
67588	9 10-14 P 959	105			
67600	10 10-15 S 962	174			
67602	FD 110-19 815	229			
67624	10 10-21 P 964	184			
67625	11 10.5-21 A 965	208			
67636	SC29-W087	300			
67637	SC29-O100	293			
67638	SC31-Y205	306			
67667	FD 110-17A 775	228			
67696	9 10-12 P 932	86			
67700	FD 70-17 820	224			
67703	9 10-19 P 973	159			
67705	FD 200-19 713	236			
67706	FD 200-20 785	238			
67766	SC29-O201	295			
67767	SC29-B200	289			
67768	SC29-Y064	302			
67770	SC29-O001	290			
67810	9 10B-17.5 P 870 (BK)	141			
67851	SC29-W035	297			
67852	SC29-Y108	303			
67853	SC29-Y082	302			
67854	SC29-B092	288			
67858	SC29-O086	293			

No.	CT	2	3		
67859	SC29-W075	300			
67860	SC29-W103	301			
67861	SC29-W061	299			
67862	SC29-B152	289			
67870	9 9-12 P 974	54			
67882	SC29-YG01	304			
67904	FT 330-29 714	271			
67905	FD 200-25 797	245			
67951	10 10-21 P 015	181			
68009	9 10-12 P 024	77			
68010	11 10.5-21 A 025	205			
68108	6 6.5B-11 S 027	37			
68109	6 6.5-11 S 028	33			
68110	6 6.5-11 S 029	33			
68111	6 6.5-11 S 030	33			
68112	6 6.5-11 S 031	34			
68113	6 6.5-11 S 032	34			
68115	6 6.5D-11 S 034	38			
68116	6 6.5B-11 S 035	37			
68118	6 6.5D-11 S 037	38			
68119	6 6.5D-11 S 525	38			
68120	6 6.5-13 S 038	39			
68121	6 6.5-13 S 039	39			
68122	6 6.5-13 S 040	39			
68123	6 6.5-13 S 446	42			
68124	6 6.5-13 S 041	40			
68125	6 6.5-13 S 042	40			
68126	6 6.5-13 S 043	40			
68127	6 6.5-13 S 559	43			
68128	6 6.5-13 S 044	41			
68129	6 6.5-13 S 045	41			
68130	6 6.5-13 S 046	41			
68131	6 6.5-13 S 047	42			
68132	6 6.5-11 S 048	34			
68133	6 6.5-11 S 051	35			
68134	6 6.5-11 S 052	35			
68135	6 6.5B-11 S 054	37			
68136	6 6.5-13 S 056	42			
68151	9 10-13.5 P 874	89			
68152	9 10-13.5 P 978	90			
68153	9 10-14 P 905 (BK)	104			
68154	9 10-14 P 906 (BK)	104			
68155	9 10P-16.5 A 926	124			

Product Overview |  
Listado de Productos

No.	CT	2 3	
68156	9 10P-18.5 A 888	148	
68158	9 10-17.5 P 023	126	
68159	11 10.5-22 A 931	211	
68160	FD 110-17A 804	229	
68161	SC31-Y215	306	
68162	SC29-Y036	301	
68207	9 10S-16 A 999	121	
68208	9 10S-16 P 999	122	
68355	9 9-14 P 053	59	
68357	9 9-10 P 861 (BK)	46	
68358	9 9-9 P 859 (BK)	45	
68359	9 9-9 P 537 (BK)	44	
68360	9 9-10 P 538 (BK)	46	
68361	9 9-10 P 576 (BK)	46	
68406	9 9K-15 P 049	64	
68407	9 9K-15 P 079	64	
68461	6S 9.5-15.5 (661 N)	32	
68534	11 10.5-16.5 A 976	195	
68589	11 10.5-21 A 062	205	
68608	9 9K-12 P 093	56	
68612	9 10-18.5 P 095 (BK)	142	
68613	9 10-18.5 P 096 (BK)	143	
68614	9 10-18.5 P 097	143	
68615	9 10-18.5 P 406 (BK)	144	
68616	9 10-18.5 P 451 (BK)	144	
68617	9 9K-12 P 100	56	
68620	9 10-14 A 103	91	
68638	9 10-12 A 104	77	
68660	9 10-12 A 118	78	
68675	9 9-12 P 937 (BK)	54	
68792	11 10.5-16.5 A 129	194	
69416	SC29-W074	300	
69417	SC29-O041	291	
69437	SC29-B110	288	
69493	9 10-14 P 188	91	
69494	10 10U-13 P 189	169	
69495	9 10-12 P 190	78	
69511	9 9-14 P 191	59	
69541	9 10-12 P 707	85	
69624	SC29-Y109	303	
69625	9 10-10 P 204	70	
69627	9 9-12 P 206	48	
69629	11 10.5-17 A 208	196	

No.	CT	2 3	
69630	FT 330-29 874	273	
69641	FT 330-29 875	274	
69643	9 10-16 P 416 (BK)	114	
69644	9 10-14 P 465 (BK)	97	
69645	9 10-12 P 487 (BK)	83	
69646	9 10-18.5 P 521 (BK)	145	
69647	9 10-17.5 P 501 (BK)	132	
69648	9 10-17.5 P 502 (BK)	132	
69649	9 10-17.5 P 467 (BK)	131	
69650	9 10-17.5 P 445 (BK)	130	
69651	9 10-14 P 492 (BK)	99	
69652	9 10B-17.5 P 554 (BK)	140	
69653	9 10-16 P 547 (BK)	116	
69654	9 10-17.5 P 574 (BK)	135	
69656	9 9-9 P 860 (BK)	45	
69657	9 9-10 P 862 (BK)	47	
69658	9 10-16 P 549 (BK)	117	
69659	9 10-18.5 P 550 (BK)	145	
69662	9 10-17.5 P 572 (BK)	134	
69690	11 10.5E-18 A 213	201	
69701	11 10.5E-16 A 214	194	
69746	11 10.5-21 A 219	206	
69747	FT 330-29 790	273	
69767	9 10-10 S 221	70	
69774	9 10-14 P 220	92	
69800	9 10-13.5 P 232	88	
69801	9 10-18.5 P 111 (BK)	143	
69914	6 6.5B-11 P 235	36	
69915	6 6.5B-11 P 236	36	
69916	6 6.5B-11 P 237	36	
69923	SC29-O054	291	
69924	SC29-O098	293	
69925	SC29-O049	291	
69926	SC29-O055	292	
69927	SC29-O073	292	
69928	SC29-W032	297	
69929	SC29-W045	298	
69930	SC29-W056	299	
69931	SC29-W067	299	
69932	SC29-Y043	301	
70010	10 10-16.5 S 262	180	
70014	SC29-R007	296	
70017	SC29-W037	298	

































No.	CT	2	3		
70019	SC29-0040	290			
70020	SC29-W042	298			
70021	SC29-O150	294			
70023	9 10S-13 P 264	88			
70115	9 10-16 A 310	108			
70118	11 10.5-24 S 276	212			
70119	11 10.5-24 S 277	213			
70120	FD 200-19A 730	238			
70121	FD 200-19 836	237			
70123	FT 330-29 821	273			
70129	6S 9.5-13	32			
70335	9 10-17.5 P 573 (BK)	134			
70658	FD 200-19 894	237			
70659	FD 200-19 895	237			
70771	11 10.5-22 S 1009	211			
70825	SC29-YG02	304			
72729	10 10-15 S 1015	175			
72932	11 10.5-13 A 168	187			
73071	10 10K-13 S 1025	169			
73310	FD 70-13 918	222			
73607	SC29-OG05	295			
73745	9 10S-18 P 1066 (BK)	142			
73746	9 10S-18 P 1067 (BK)	142			
73770	9 10S-16 P 1068 (BK)	122			
73833	11 10.5-19 A 1069	204			
73913	10 10.5V-24 S 1060	186			
74205	9 10-17.5 P 169	127			
74324	SK 37-6 P02	307			
74328	99-14 P 1094	62			
74618	11 10.5-13 A 1132	187			
74663	9 10-19 P 1138	160			
74762	9 10-18.5 P 1139 (BK)	146			
74765	10 10-15 P 1140	175			
74766	11 10.5-15 A 1141	190			
74767	99-14 P 1142	62			
74768	9 10-14 P 1143	105			
74769	99-14 P 1144	63			
74790	9 10-12 P 1145	87			
74791	99-14 P 1146	63			
74792	99K-15 P 1147	67			
74843	99L-10 P 1150	47			
74882	9 10S-17 P 1152 (BK)	125			
74883	9 10S-17 P 1153 (BK)	125			



No.	CT	2	3		
74884	9 10S-17 P 1154 (BK)	126			
74911	99-12 P 1155	55			
74915	6602 N P02	43			
74916	6603 N P01	44			
75007	99M-13 P 1156	57			
75142	FT 330-29 1007	274			
75179	99M-13 P 1181	57			
75180	99M-13 P 1182	57			
75183	9 10-18.5 P 1183	147			
75184	FD 200-25 1008	245			
75221	9 10-21 A 1187	165			
75266	9 10BS-17 P 1192 (BK)	124			
75267	9 10BS-17 P 1193	124			
75268	10 10.5V-22 S 1179	186			
75269	11 10.5D-21 S 1063	209			
75313	SC29-B093	288			
75314	SC29-O155	294			
75315	SC29-O132	294			
75410	99M-13 P 1197	58			
75412	99M-13 P 1196	58			
75464	11 10.5-24 S 1200	213			
75465	11 10.5-22 S 1199	212			
75561	9 10S-17 P 1206	126			
75562	9 10-17.5 A 1205	139			
75626	9 10-14 A 312	92			
75707	SC29-YC07	303			
75741	10 10.5C-13 P 1226	184			
75972	10 10-16 S 1239	178			
75973	9 10-16 P 1240	119			
75977	FD 200-19 761	236			
76150	11 10.5-19 A 1250	204			
76151	9 10-19 P 1251	160			
77093	9 10AS-21 P 1280	166			
77120	FD 200-19 1148	238			
77199	FD 530-35 1165	263			
77202	99M-13 P 1283	58			
77203	9 10-12 A 1284	87			
77340	FT 430-35 1178	274			
77391	9 10P-18.5 P 195	147			
77427	99M-13 P 1290	59			
77432	99-12 P 1292	55			
77433	9 10-12 P 1291	87			
77546	SC17-WC08	286			

Product Overview | Listado de Productos

No.	CT	2 3	
77547	SC17-WC09	286	
77548	SC17-WC10	286	
77549	SC17-WC11	287	
77550	SC26-WC12	287	
77593	9 10BS-17 P 1193 (BK)	125	
77614	9 10S-16 S 382	121	
77616	9 9K-15 P 1298	67	
77618	9 9K-15 P 1299	67	
77699	9 10-16 P 1309	119	
77705	9 9-14 P 1308	63	
77754	11 10.5-17 A 133	195	
77797	9 9-14 P 1319	64	
77809	9 10-21 P 900	165	
77833	11 10.5E-19 S 1320	205	
77861	9 10-18.5 P 1322	147	
77963	10 10A-12 P 1330	168	
78015	9 10-17.5 P 136 (BK)	127	
78046	11 10.5-21 A 1339	208	
78074	9 10-21 A 1332 (BK)	165	
78139	10 10.5-15 P 1036	185	
78161	10 10-21 P 1000	184	
78162	10 10-21 P 299	182	
78163	10 10B-16 P 162	179	
78164	10 10K-13 P 163	168	
78165	11 10.5-17 A 170	196	
78166	11 10.5-19 A 1047	204	
78170	11 10.5D-21 S 788	208	
78171	6 6.5F-15 S 211	43	
78172	9 10-10.5 P 122 (BK)	76	
78176	9 10-14 P 297	92	
78177	9 10-14 P 1029	105	
78178	9 10-14 P 1189	106	
78179	9 10-17.5 P 892 (BK)	138	
78181	9 10-17.5 P 173	127	
78183	9 10-14 P 534	100	
78220	9 10-17.5 P 175	128	
78221	9 10-17.5 P 1056	139	
78223	9 10-19 P 901	158	
78224	9 10-19 A 084	149	
78225	9 10C-13.5 P 1082	91	
78226	9 10P-16.5 P 194	123	
78227	9 10P-18.5 A 998	148	
78228	9 10P-18.5 P 1113	149	

No.	CT	2 3	
78229	9 10P-18.5 P 1207	149	
78230	9 10P-19 P 1362	161	
78231	10 10K-14 S 1022	171	
78232	9 9-14 P 737	61	
78233	9 9A-20 P 1363	68	
78234	9 9J-20 P 776	69	
78235	FD 530-35 912	262	
78236	FT 530-35 924	283	
78237	11 10.5-22 S 1221	212	
78238	10 10.5AV-16 P 1222	186	
78239	10 10.5AV-16 P 1219	185	
78241	10 10K-14 S 1024	171	
78242	9 10JS-13 S 1104	88	
78243	9 10BS-14 S 1096	107	
78244	10 10BS-14 S 1124	170	
78245	FT 530-32 1088	278	
78246	FD 200-22A 1062	240	
78247	6 6.5-11 S 1259	35	
78248	10 10S-14 S 1095 (BK)	172	
78249	9 10SW-14 S 1208 (BK)	107	
78311	10 10A-16 P 1106	179	
78312	10 10A-16 P 1105	179	
78313	10 10A-16 P 1102	178	
78314	10 10B-14 P 165	170	
78315	10 10B-15 P 166	175	
78316	10 10K-14 P 167	170	
78317	10 10K-15 P 164	176	
78318	10 10K-15 P 1033	176	
78319	10 10K-15 P 1034	176	
78328	9 10-14 P 1359	106	
78330	10 10K-15 P 1035	177	
78331	10 10K-20 P 1114	181	
78332	10 10K-20 P 1059	181	
78333	11 10.5-22 A 020	209	
78334	9 10-12 P 022	77	
78360	SK 125-101 P01	307	
78379	SC29-OG13	295	
78405	SC29-BG07	289	
78410	SC29-YG14	304	
78411	SC29-O076	292	
78412	SC29-R080	297	
78413	SC29-Y044	302	
78414	SC29-B083	287	

No.	CT	2 3	 
78417	SC29-BG08	290	
78418	SC29-PG09	296	
78421	SC31-BG10	305	
78422	SC31-OG11	305	
78423	SC31-BG12	305	
78601	9 10-17.5 P 1388	139	
78638	9 10-13.5 P 1394	90	
78687	FT 430-35 1188	275	
79093	11 10.5B-16.5 P 279	195	
79614	9 9-12 P 1476	55	 
600554	FD 530-35 1316	263	
600568	9 10-19.5 P 801	161	
600688	9 10J-16 S 1551	120	
600720	FT 430-35 1314	275	
600804	9 9K-16 P 1568	68	
600929	FD 200-22 A 908	240	
600932	9 10SW-14 S 1574 (BK)	107	 
601025	FT 430-35 1298	275	
601035	9 10-21 P 1581	166	
601421	9 10-14 A 959	104	
601536	9 9L-10 P 1594	47	
601538	9 10S-16 P 1600	122	
601539	9 10-16 P 1602	119	
601575	SC29-P116	296	
601634	10 10-13 S 1614	168	
601784	9 10-19 P 1617	160	
601986	9 10S-16 P 1631	123	
601989	9 10S-16 A 1634	123	

No.	CT	2 3	 
-----	----	-----	---



# Rolling Lobe Air Springs

Bolsas de Aire Automotrices



### 5S 8-15.5 (644N)

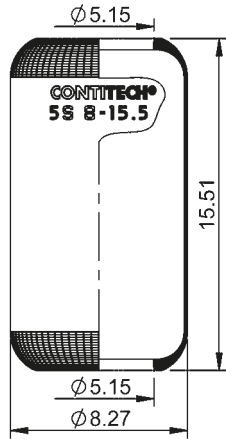

66141



3.4 lb

**Cross-reference | Cruce de Referencia**

Firestone	W01-095-0118
	W01-358-5139
Goodyear	8017

**Manufacturer | Fabricante**

EvoBus	A 327 328 00 01
Kässbohrer	4771441000
EvoBus	A 613 327 00 01
Neoplan	AA 10-01-300
Van Hool	624319-420
	624319-610
Volvo	1 134 445
	1 199 893
and more	

### 6S 9.5-13

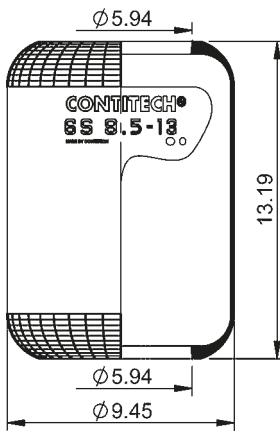

70129



3.4 lb

**Cross-reference | Cruce de Referencia**

Firestone	W01-095-0087
	W01-358-5158
Goodyear	8015

**Manufacturer | Fabricante**

MAN	81436010083
	81436010113
	81436010117
Mercedes	A 363 328 00 01
Renault	5000819517
Volvo	6885533
IRISBUS	5000819517
IVECO Bus	4763473
and more	

### 6S 9.5-15.5 (661 N)

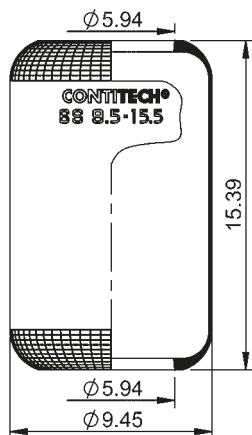

68461



3.8 lb

**Cross-reference | Cruce de Referencia**

Firestone	W01-095-0021
	W01-358-5150
Goodyear	8018

**Manufacturer | Fabricante**

EvoBus	A 410 327 00 01
IVECO Bus	41822247
	4746733
Kässbohrer	4731012000
	4771440000
MB Tuerk	A 613 327 02 01
Neoplan	AA 10-01-001
Van Hool	624319-670
and more	



### 66.5-11 S 028

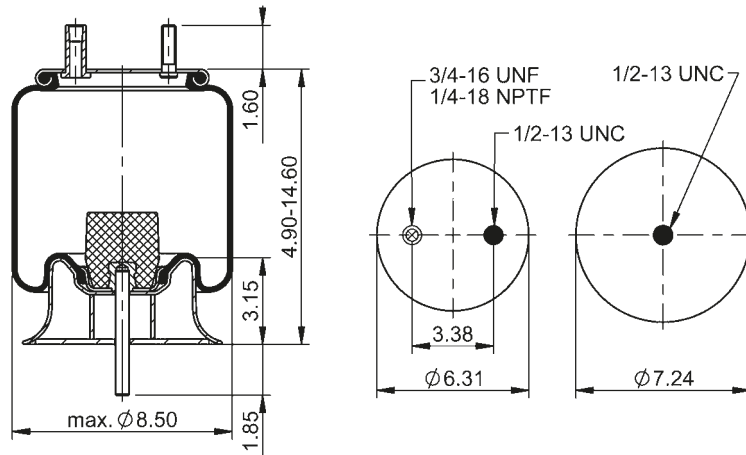

68109



**lb** 8.3 lb **No.** 9312910

**Cross-reference | Cruce de Referencia**  
Firestone W01-358-2120

**Manufacturer | Fabricante**  
Granning 5691  
6104  
Rowe Truck ASCS2000

1/4-18 NPTF: max. 22 lb-ft  
1/2-13 UNC: max. 35 lb-ft  
3/4-16 UNF: max. 50 lb-ft

### 66.5-11 S 029

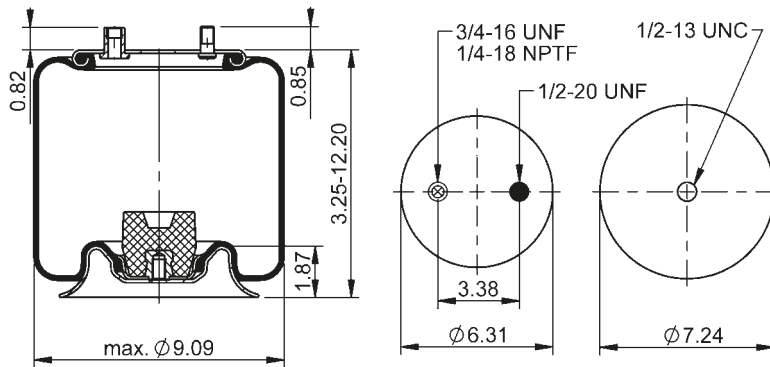

68110



**lb** 7.2 lb **No.** 9312902

**Cross-reference | Cruce de Referencia**  
Firestone W01-358-2131

1/4-18 NPTF: max. 22 lb-ft  
1/2-20 UNF: max. 35 lb-ft  
3/4-16 UNF: max. 50 lb-ft

### 66.5-11 S 030

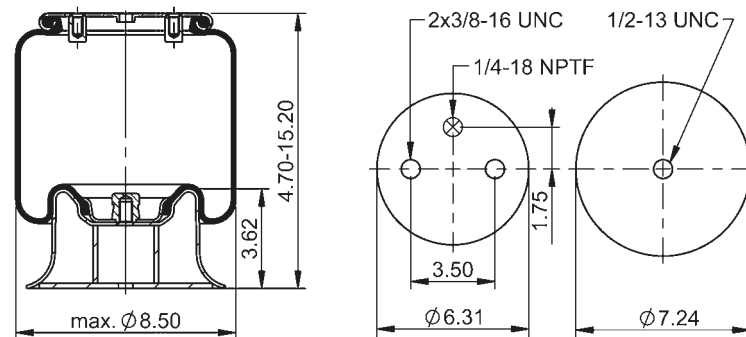

68111



**lb** 7.5 lb **No.** 9312900

**Cross-reference | Cruce de Referencia**  
Firestone W01-358-5310

**Manufacturer | Fabricante**  
American Carrier 9003-001  
Flexible 6-336-2  
Hendrickson S-8832  
Ridewell 1003585310C

1/4-18 NPTF: max. 22 lb-ft  
3/8-16 UNC: max. 20 lb-ft  
1/2-13 UNC: max. 35 lb-ft

### 66.5-11 S 031

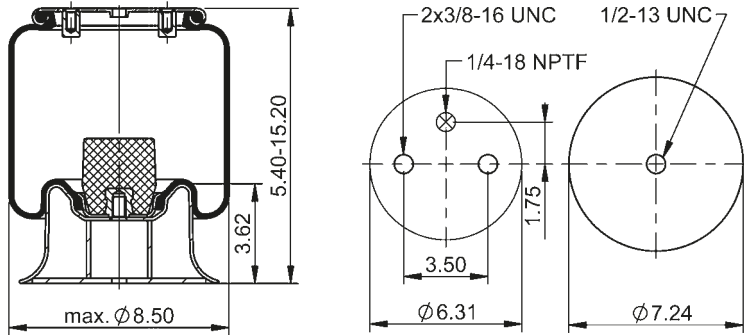

### 68112

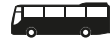

**lb** 8.2 lb **No.** 9312900

**Cross-reference | Cruce de Referencia**  
Firestone W01-358-5311

**Manufacturer | Fabricante**  
American Carrier 8003-017  
Flexible 6-379-1  
Ridewell 1003585311C

1/4-18 NPTF: max. 22 lb-ft  
3/8-16 UNC: max. 20 lb-ft  
1/2-13 UNC: max. 35 lb-ft

### 66.5-11 S 032

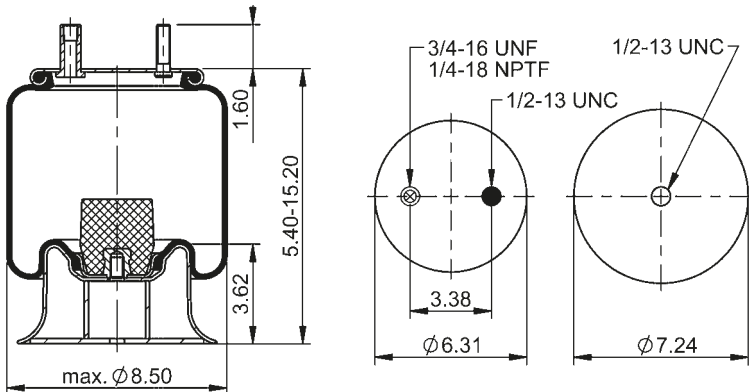

### 68113



**lb** 8.3 lb **No.** 9312900

**Cross-reference | Cruce de Referencia**  
Firestone W01-358-5323

**Manufacturer | Fabricante**  
Granning 7504  
Ridewell 1003585323C

1/4-18 NPTF: max. 22 lb-ft  
1/2-13 UNC: max. 35 lb-ft  
3/4-16 UNF: max. 50 lb-ft

### 66.5-11 S 048

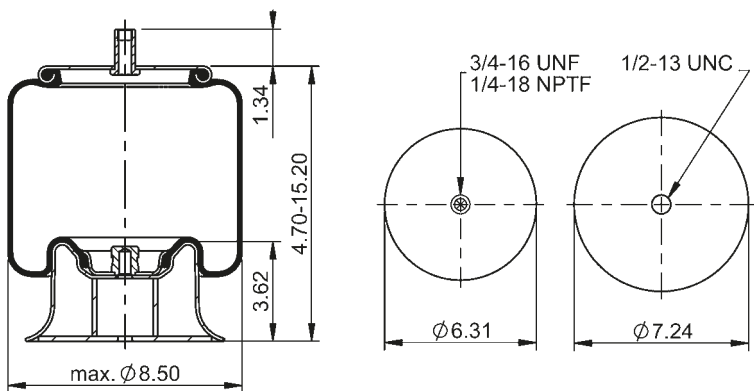

### 68132



**lb** 7.5 lb **No.** 9312900

**Cross-reference | Cruce de Referencia**  
Firestone W01-358-5300

**Manufacturer | Fabricante**  
Flexible 6-336-4

### 66.5-11 S 051

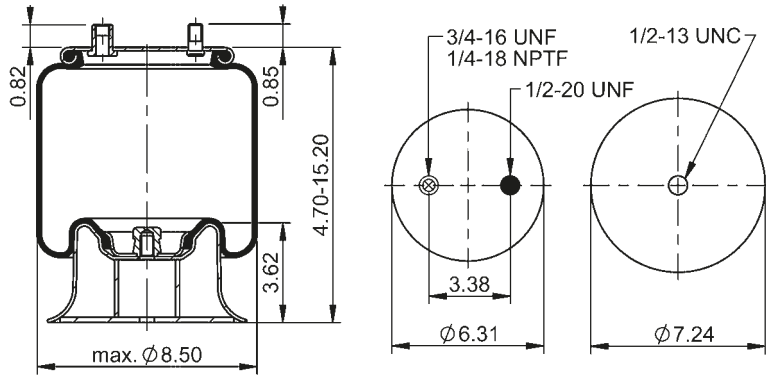

68133



**lb** 7.5 lb **No.** 9312900

**Cross-reference | Cruce de Referencia**  
Firestone W01-358-5315

**Manufacturer | Fabricante**  
Flxible 6-379-6

**1/4-18 NPTF:** max. 22 lb-ft  
**1/2-20 UNF:** max. 35 lb-ft  
**3/4-16 UNF:** max. 50 lb-ft

### 66.5-11 S 052

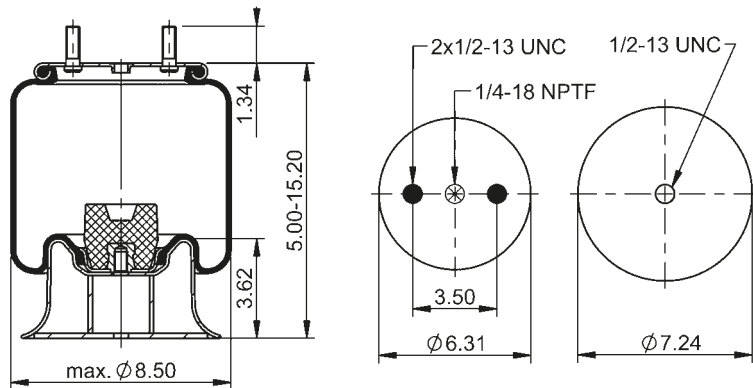

68134



**lb** 8.1 lb **No.** 9312900

**Cross-reference | Cruce de Referencia**  
Firestone W01-358-5316

**Manufacturer | Fabricante**  
New Flyer 6160104

**1/4-18 NPTF:** max. 22 lb-ft  
**1/2-13 UNC:** max. 35 lb-ft

### 66.5-11 S 1259

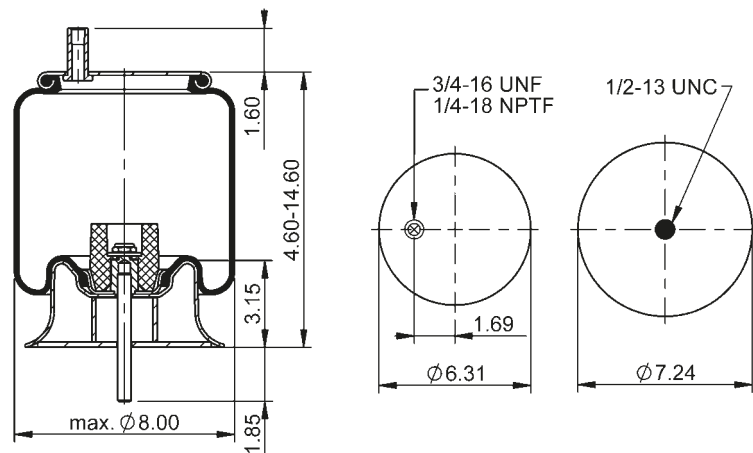

78247



**lb** 11.0 lb **No.** 9312910

**Manufacturer | Fabricante**  
Hendrickson 78824-000

**1/4-18 NPTF:** max. 22 lb-ft  
**1/2-13 UNC:** max. 35 lb-ft  
**3/4-16 UNF:** max. 50 lb-ft

### 6 6.5B-11 P 235

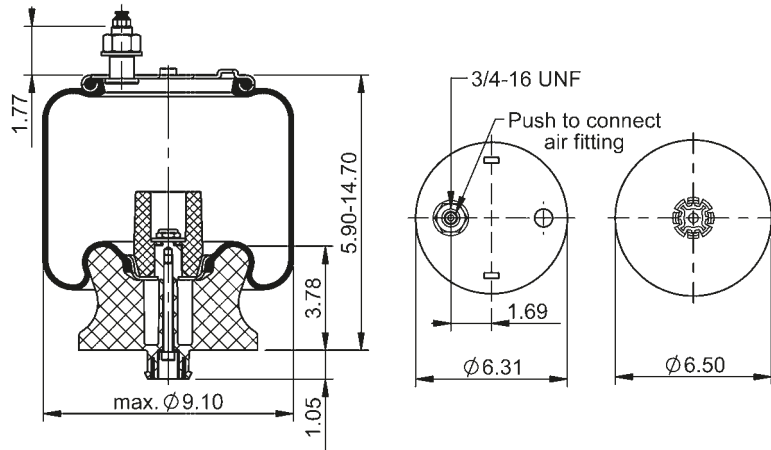

69914



**lb** 7.5 lb **No.** 9314165

**Cross-reference | Cruce de Referencia**  
Firestone W26-358-9911

**Manufacturer | Fabricante**  
Hendrickson 59823-2C  
69782-002

1/4-18 NPTF: max. 22 lbft  
3/4-16 UNF: max. 50 lbft

### 6 6.5B-11 P 236

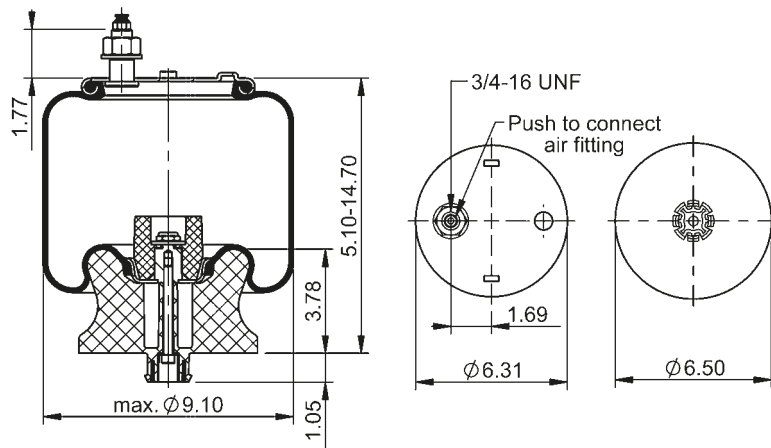

69915



**lb** 7.4 lb **No.** 9314165

**Cross-reference | Cruce de Referencia**  
Firestone W26-358-9912  
W26-358-9913

**Manufacturer | Fabricante**  
Hendrickson 60750-2  
60750-2E  
64075-2  
66349-2  
Mack 57QL55M  
Volvo 20462934  
20897204

1/4-18 NPTF: max. 22 lbft  
3/4-16 UNF: max. 50 lbft

### 6 6.5B-11 P 237

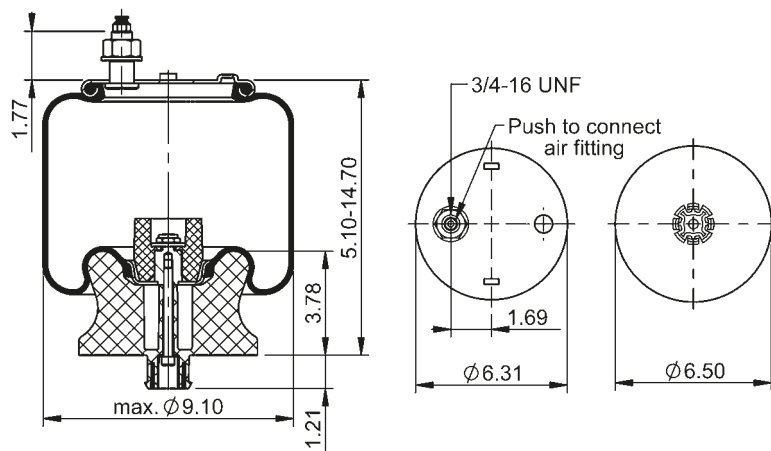

69916



**lb** 7.5 lb **No.** 9314166

**Manufacturer | Fabricante**  
Hendrickson 67304-2

1/4-18 NPTF: max. 22 lbft  
3/4-16 UNF: max. 50 lbft

### 66.5B-11 S 027

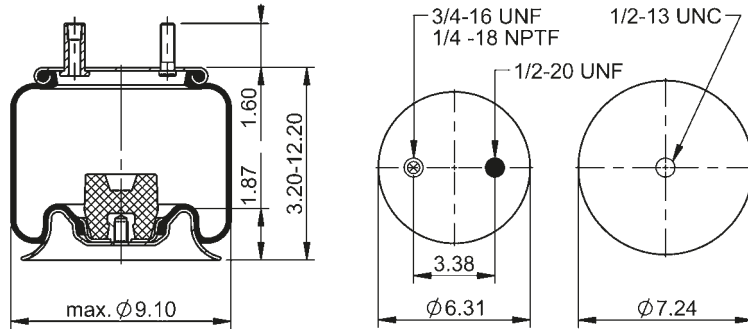

68108



**lb** 7.2 lb **No.** 9312902

**Cross-reference | Cruce de Referencia**

Firestone W01-358-2119  
Goodyear 1R9-065

**Manufacturer | Fabricante**

Granning 5122  
Hendrickson S-2394  
Rowe Truck ASC1400HL

1/4-18 NPTF: max. 22 lbft  
1/2-20 UNF: max. 35 lbft  
3/4-16 UNF: max. 50 lbft

### 66.5B-11 S 035

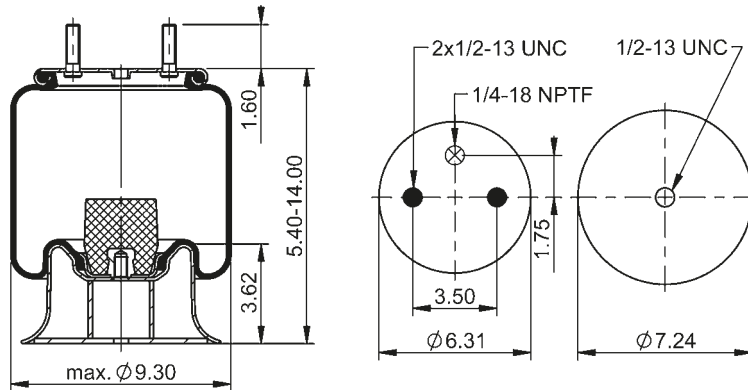

68116



**lb** 8.2 lb **No.** 9312900

**Cross-reference | Cruce de Referencia**

Firestone W01-358-5319

**Manufacturer | Fabricante**

Monaco Coach 8618

1/4-18 NPTF: max. 22 lbft  
1/2-13 UNC: max. 35 lbft

### 66.5B-11 S 054

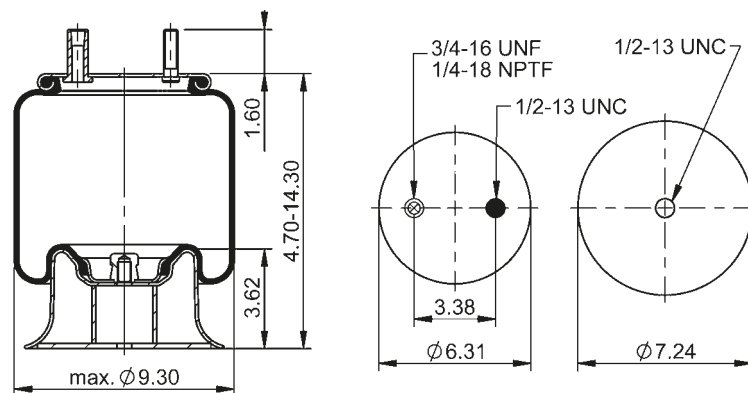

68135



**lb** 7.4 lb **No.** 9312900

**Cross-reference | Cruce de Referencia**

Firestone W01-358-5298

**Manufacturer | Fabricante**

Gillig 0837209-000N

1/4-18 NPTF: max. 22 lbft  
1/2-13 UNC: max. 35 lbft  
3/4-16 UNF: max. 50 lbft

### 6 6.5D-11 S 034

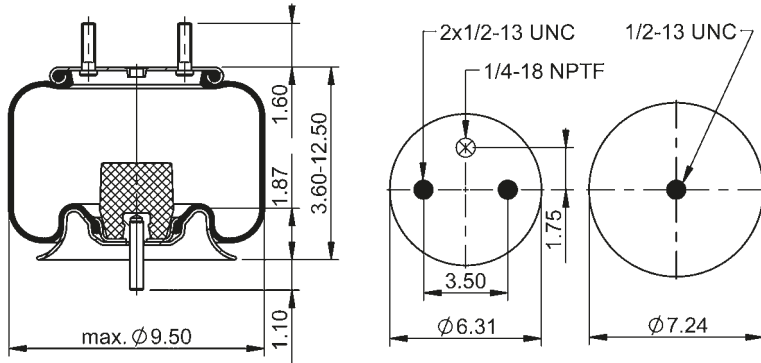

### 68115



**lb** 7.4 lb **No.** 9312902

**Cross-reference | Cruce de Referencia**  
Firestone W01-358-5297

**Manufacturer | Fabricante**  
Watson & Chalin AS-0106

1/4-18 NPTF: max. 22 lb-ft  
1/2-13 UNC: max. 35 lb-ft

### 6 6.5D-11 S 037

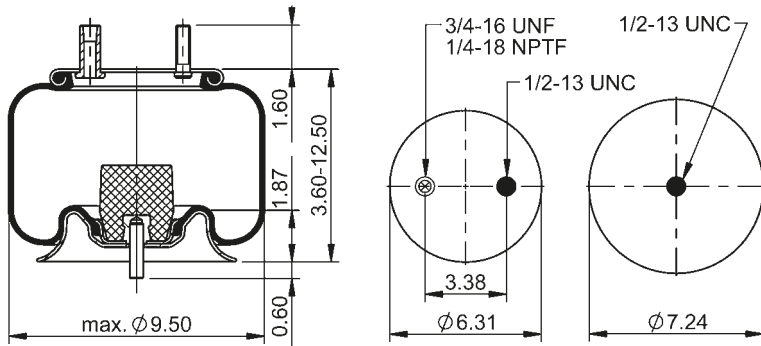

### 68118



**lb** 7.4 lb **No.** 9312902

**Cross-reference | Cruce de Referencia**  
Firestone W01-358-8992

**Manufacturer | Fabricante**  
Ridewell 1003588992C

1/4-18 NPTF: max. 22 lb-ft  
1/2-13 UNC: max. 35 lb-ft  
3/4-16 UNF: max. 50 lb-ft

### 6 6.5D-11 S 525

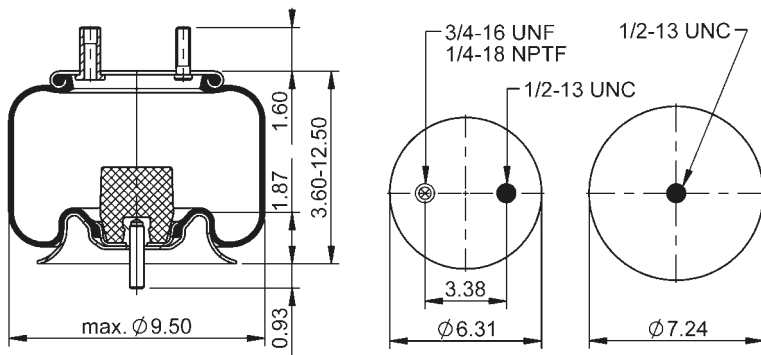

### 68119



**lb** 7.5 lb **No.** 9312902

**Cross-reference | Cruce de Referencia**  
Firestone W01-358-8997  
Goodyear 1R9-065

**Manufacturer | Fabricante**  
Bluebird 300-961425  
1263581  
Flexible 6-336-196  
SAF Holland 90557029  
90557034  
Watson & Chalin AS-0026

1/4-18 NPTF: max. 22 lb-ft  
1/2-13 UNC: max. 35 lb-ft  
3/4-16 UNF: max. 50 lb-ft

### 66.5-13 S 038

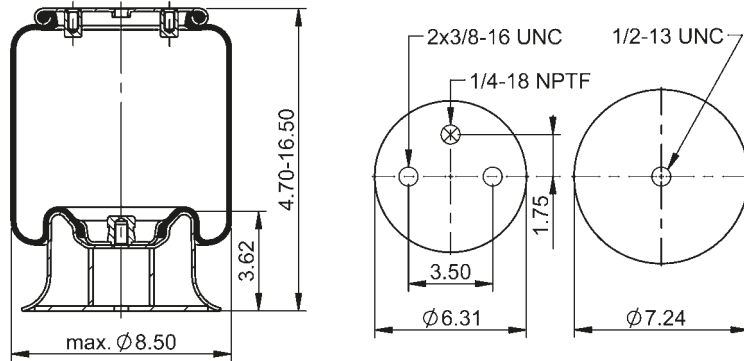

68120



**lb** 7.5 lb **No.** 9312900

**Cross-reference | Cruce de Referencia**  
Firestone W01-358-5405

**Manufacturer | Fabricante**  
Hendrickson S-9346

1/4-18 NPTF: max. 22 lb-ft  
3/8-16 UNC: max. 20 lb-ft

### 66.5-13 S 039

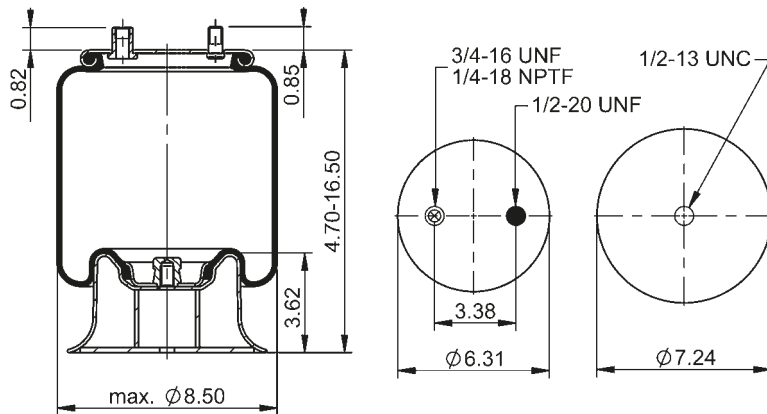

68121



**lb** 7.6 lb **No.** 9312900

**Cross-reference | Cruce de Referencia**  
Firestone W01-358-5406  
Goodyear 1R9-038

**Manufacturer | Fabricante**  
GMC 662743  
716111  
8865456  
Granning 1971  
15765

1/4-18 NPTF: max. 22 lb-ft  
1/2-20 UNF: max. 35 lb-ft  
3/4-16 UNF: max. 50 lb-ft

### 66.5-13 S 040

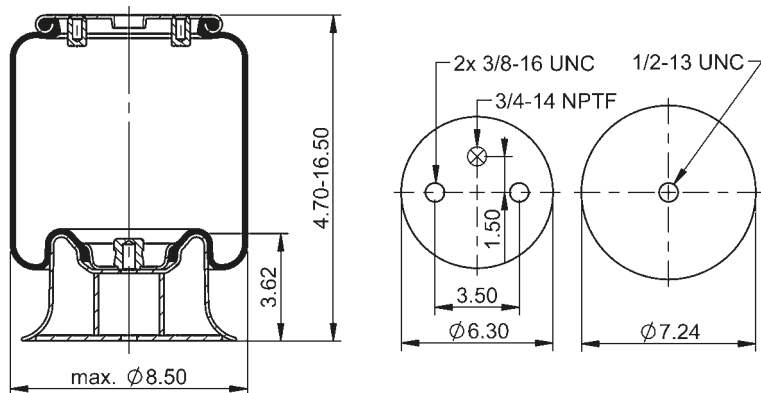

68122



**lb** 7.7 lb **No.** 9312900

**Cross-reference | Cruce de Referencia**  
Firestone W01-358-5408

3/8-16 UNC: max. 20 lb-ft  
3/4-14 NPTF: max. 22 lb-ft

### 66.5-13 S 041

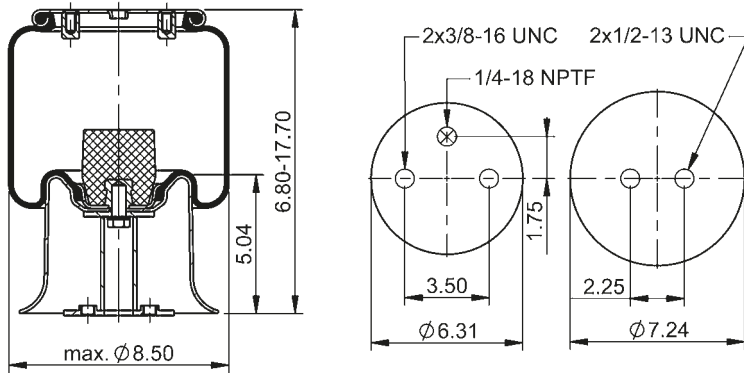

### 68124



**lb** 10.2 lb **No.** 9312935

**Cross-reference | Cruce de Referencia**  
Firestone W01-358-5412

**Manufacturer | Fabricante**  
American Carrier 8003-011  
Ridewell 1003585412C  
SAF Holland 90057057

- 1/4-18 NPTF: max. 22 lb-ft
- 3/8-16 UNC: max. 20 lb-ft
- 1/2-13 UNC: max. 35 lb-ft

### 66.5-13 S 042

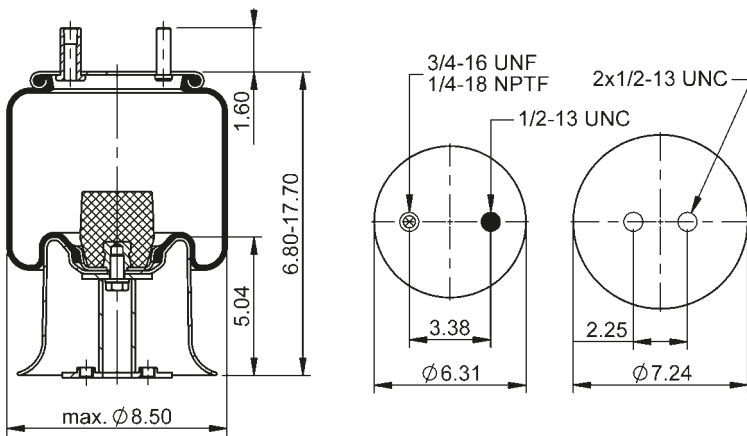

### 68125



**lb** 10.3 lb **No.** 9312935

**Cross-reference | Cruce de Referencia**  
Firestone W01-358-5414

**Manufacturer | Fabricante**  
Eldorado Bus 7113D000  
Hendrickson S-13155  
Ridewell 1003585414C

- 1/4-18 NPTF: max. 22 lb-ft
- 1/2-13 UNC: max. 35 lb-ft
- 3/4-16 UNF: max. 50 lb-ft

### 66.5-13 S 043

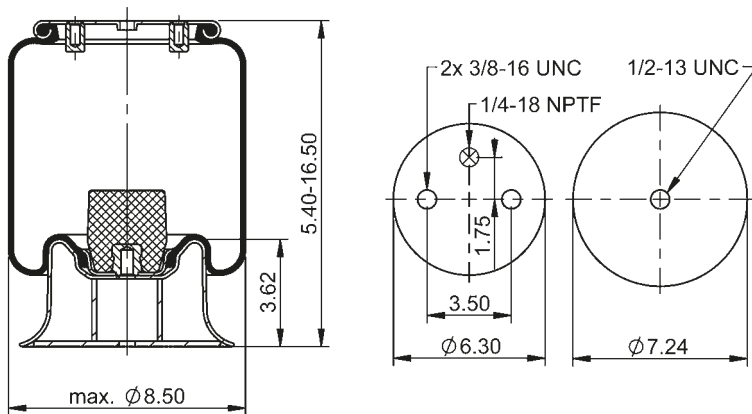

### 68126



**lb** 8.4 lb **No.** 9312900

**Cross-reference | Cruce de Referencia**  
Firestone W01-358-5422

- 1/4-18 NPTF: max. 22 lb-ft
- 3/8-16 UNC: max. 20 lb-ft



### 66.5-13 S 044

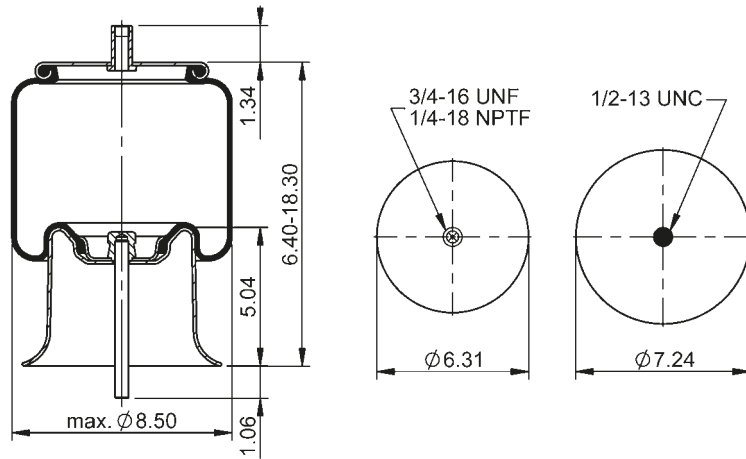

68128



**lb** 8.5 lb **No.** 9312901

**Cross-reference | Cruce de Referencia**  
Firestone W01-358-5433

**Manufacturer | Fabricante**  
Watson & Chalin AS-0069

1/4-18 NPTF: max. 22 lb-ft  
1/2-13 UNC: max. 35 lb-ft  
3/4-16 UNF: max. 50 lb-ft

### 66.5-13 S 045

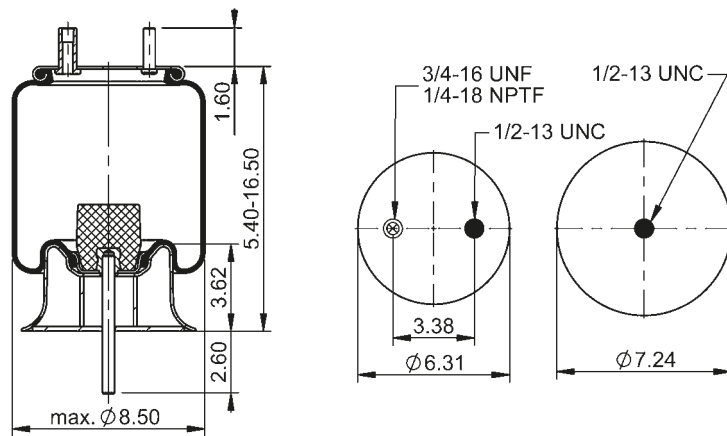

68129



**lb** 8.6 lb **No.** 9312900

**Cross-reference | Cruce de Referencia**  
Firestone W01-358-5434

**Manufacturer | Fabricante**  
Granning 7765

1/4-18 NPTF: max. 22 lb-ft  
1/2-13 UNC: max. 35 lb-ft  
3/4-16 UNF: max. 50 lb-ft

### 66.5-13 S 046

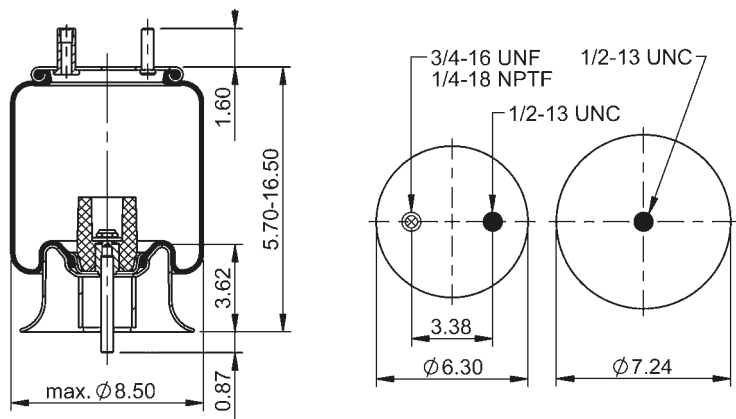

68130



**lb** 8.8 lb **No.** 9312900

**Cross-reference | Cruce de Referencia**  
Firestone W01-358-5436

**Manufacturer | Fabricante**  
Granning 7831  
Tuthill

1/4-18 NPTF: max. 22 lb-ft  
1/2-13 UNC: max. 35 lb-ft  
3/4-16 UNF: max. 50 lb-ft

### 66.5-13 S 047

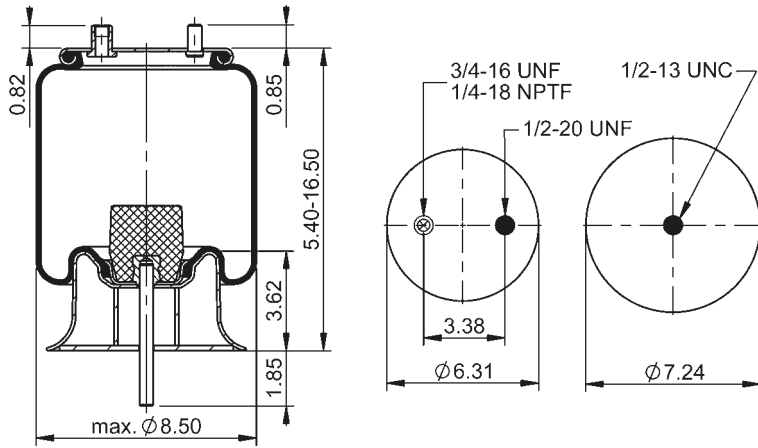

### 68131



**lb** 8.6 lb **No.** 9312900

**Cross-reference | Cruce de Referencia**  
Firestone W01-358-9478

**Manufacturer | Fabricante**  
Granning 6250

- 1/4-18 NPTF: max. 22 lb-ft
- 1/2-13 UNC: max. 35 lb-ft
- 3/4-16 UNF: max. 50 lb-ft

### 66.5-13 S 056

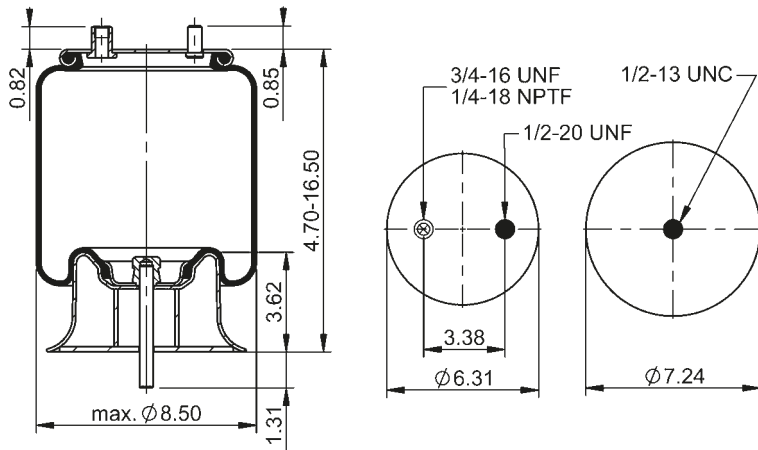

### 68136



**lb** 7.7 lb **No.** 9312900

**Cross-reference | Cruce de Referencia**  
Firestone W01-358-5409  
W01-358-5435  
Goodyear 1R9-003

**Manufacturer | Fabricante**

- Flxible 6-336-11
- GMC 662743
- New Flyer 5920815
- 5973877
- 5973923
- 5993113

- 1/4-18 NPTF: max. 22 lb-ft
- 1/2-13 UNC: max. 35 lb-ft
- 3/4-16 UNF: max. 50 lb-ft

### 66.5-13 S 446

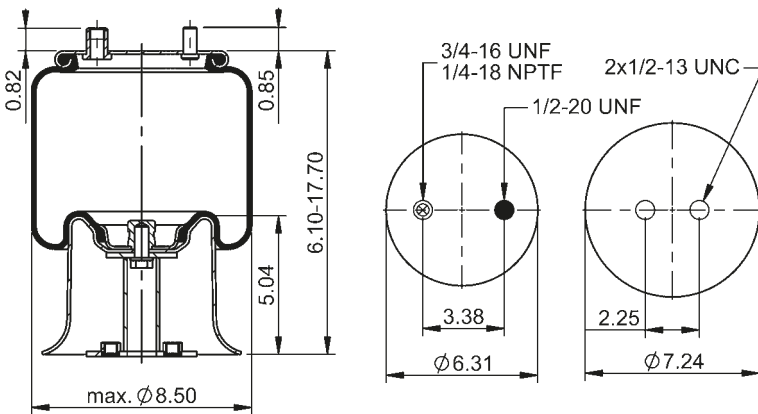

### 68123



**lb** 8.8 lb **No.** 9312935

**Cross-reference | Cruce de Referencia**  
Firestone W01-358-5410  
Goodyear 1R9-070

**Manufacturer | Fabricante**

- Granning 2112
- Ridewell 1003585410C
- SAF Holland 57005410
- Watson & Chalin AS-0029

- 1/4-18 NPTF: max. 22 lb-ft
- 1/2-13 UNC: max. 35 lb-ft
- 3/4-16 UNF: max. 50 lb-ft

### 66.5-13 S 559

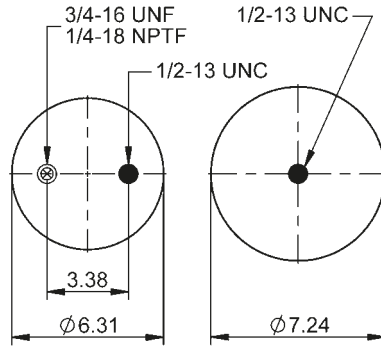
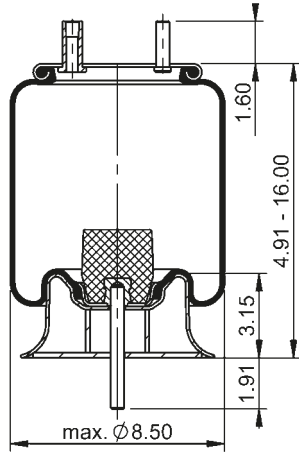

68127



**lb** 9.9 lb **No.** 9312910

**Cross-reference | Cruce de Referencia**  
Firestone W01-358-5423

**Manufacturer | Fabricante**  
Granning 5235  
5307

1/4-18 NPTF: max. 22 lb-ft  
1/2-13 UNC: max. 35 lb-ft  
3/4-16 UNF: max. 50 lb-ft

### 66.5F-15 S 211

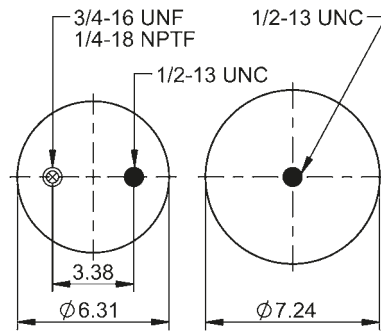
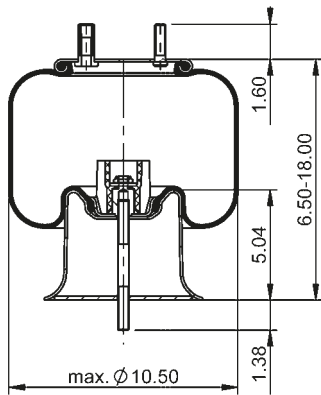

78171



**lb** 8.8 lb

**Manufacturer | Fabricante**  
SAF Holland 90557412

1/4-18 NPTF: max. 22 lb-ft  
1/2-13 UNC: max. 35 lb-ft  
3/4-16 UNF: max. 50 lb-ft

### 6602 N P02

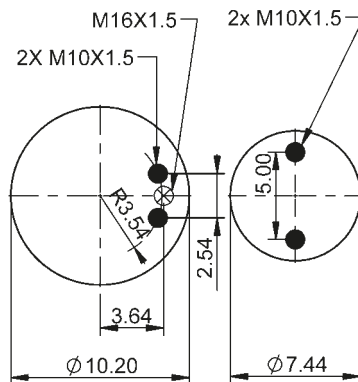
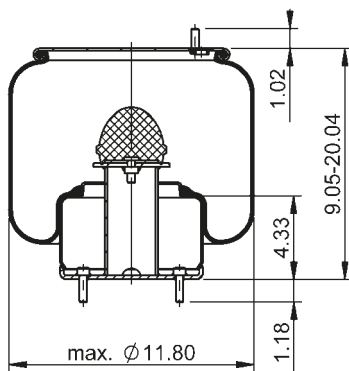

74915



**lb** 17.2 lb **No.** 9311801 6602 N P01

**Cross-reference | Cruce de Referencia**  
Goodyear 1R12-843

**Manufacturer | Fabricante**  
Volvo 21 041 697  
20 573 113  
20 480 202  
70 313 734  
21 097 453  
70 397 453  
70 321 079

M10: max. 20 lb-ft  
M16x1.5: max. 22 lb-ft

### 6603 N P01

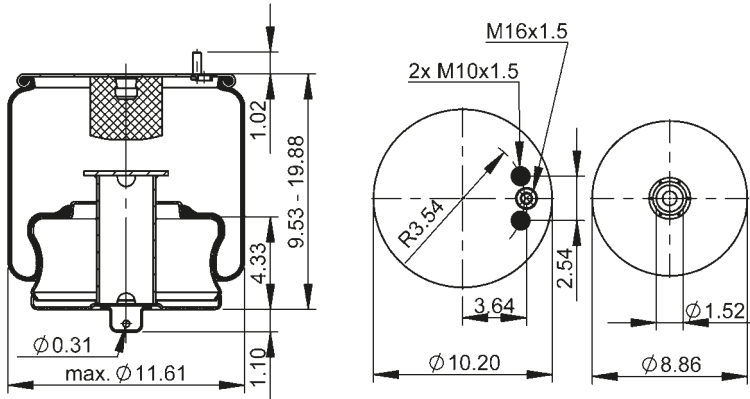

### 74916



**lb** 18.5 lb **No.** 9309795

**Cross-reference | Cruce de Referencia**  
Goodyear 1R11-893

**Manufacturer | Fabricante**  
Volvo 20 573 312  
3 171 693  
3 178 706  
3 195 240

M10: max. 20 lb-ft  
M16x1.5: max. 22 lb-ft

### 99-9 P 537 (BK)

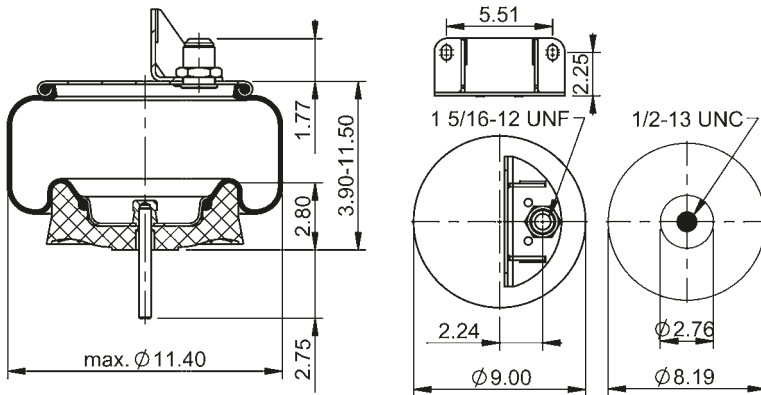

### 68359



**lb** 11.3 lb **No.** 9311561

**Cross-reference | Cruce de Referencia**  
Firestone W01-358-9622  
Goodyear 1R11-221

**Manufacturer | Fabricante**  
Kenworth K-303-22

1/2-13 UNC: max. 35 lb-ft  
1 5/16-12 UNF: max. 35 lb-ft

### 99-9 P 756

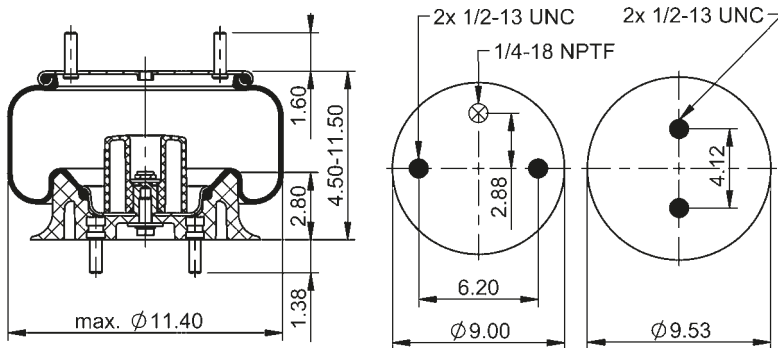

### 64700



**lb** 9.8 lb **No.** 9308624

**Cross-reference | Cruce de Referencia**  
Firestone W01-358-9651

**Manufacturer | Fabricante**  
Monaco Coach 0180 6160

1/4-18 NPTF: max. 22 lb-ft  
1/2-13 UNC: max. 35 lb-ft

### 99-9 P 767

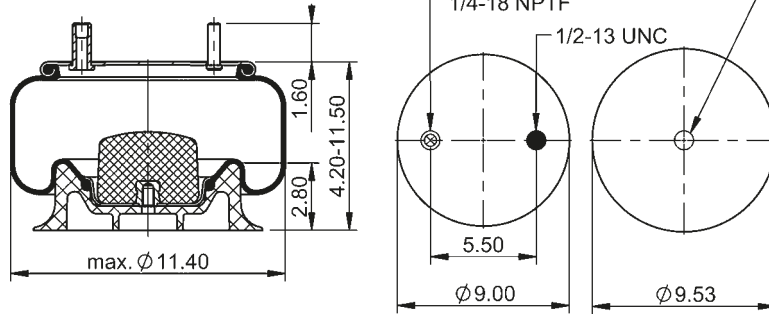

64713



**lb** 10.3 lb **No.** 9308127

**Cross-reference | Cruce de Referencia**  
 Firestone W01-358-5789

**Manufacturer | Fabricante**  
 Link 1103-0503

1/4-18 NPTF: max. 22 lb-ft  
 1/2-13 UNC: max. 35 lb-ft  
 3/4-16 UNF: max. 50 lb-ft

### 99-9 P 859 (BK)

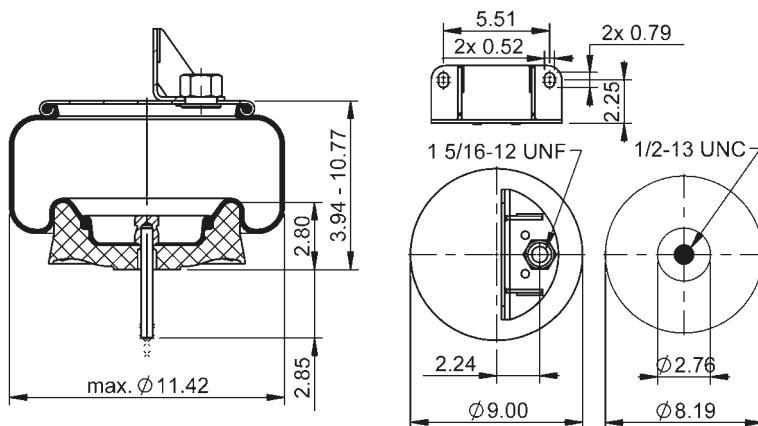

68358



**lb** 11.9 lb **No.** 9311561

**Cross-reference | Cruce de Referencia**  
 Firestone W01-358-9547  
 Goodyear 1R11-268

**Manufacturer | Fabricante**  
 Kenworth C81-1004

1/2-13 UNC: max. 35 lb-ft  
 1 5/16-12 UNF: max. 35 lb-ft

### 99-9 P 860 (BK)

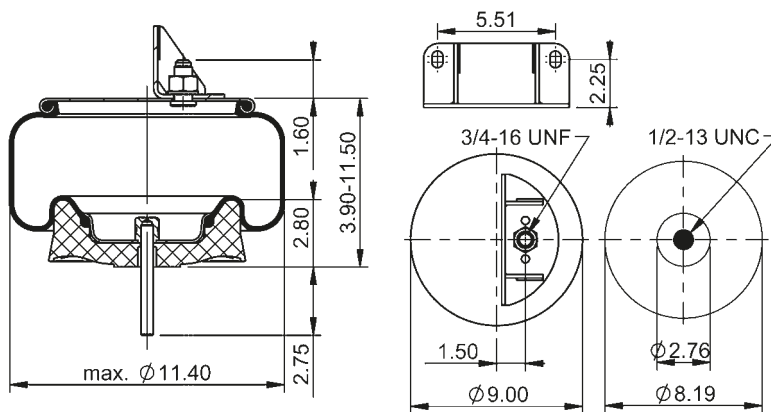

69656



**lb** 8.9 lb **No.** 9311561

**Cross-reference | Cruce de Referencia**  
 Firestone W01-358-9617  
 Goodyear 1R11-219

**Manufacturer | Fabricante**  
 Kenworth K-303-18

1/2-13 UNC: max. 35 lb-ft  
 3/4-16 UNF: max. 50 lb-ft

### 99-10 P 538 (BK)

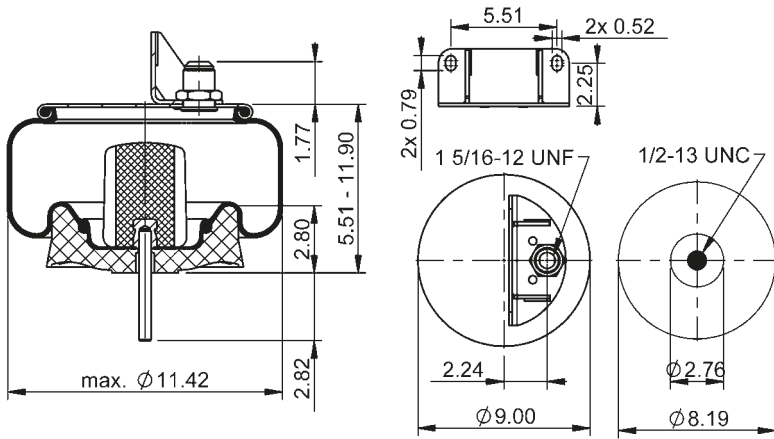

68360



**lb** 13.5 lb **No.** 9311561

**Cross-reference | Cruce de Referencia**  
 Firestone W01-358-9625  
 Goodyear 1R11-222

**Manufacturer | Fabricante**  
 Kenworth K-303-23  
 K-303-25

1/2-13 UNC: max. 35 lbft  
 1 5/16-12 UNF: max. 35 lbft

### 99-10 P 576 (BK)

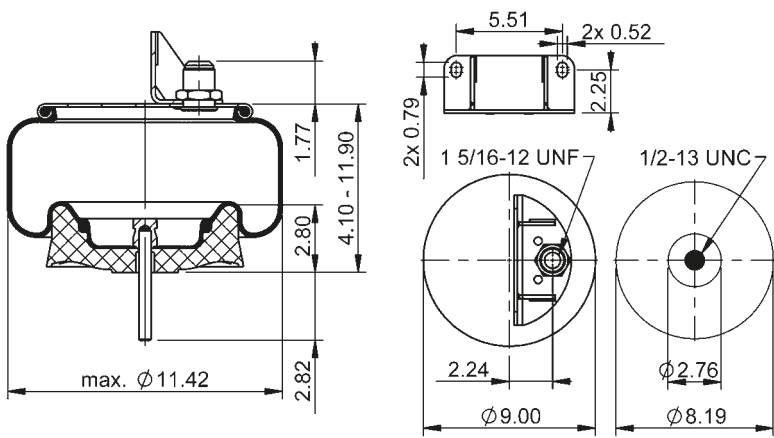

68361



**lb** 11.6 lb **No.** 9311561

**Cross-reference | Cruce de Referencia**  
 Firestone W01-358-9675  
 Goodyear 1R11-221

**Manufacturer | Fabricante**  
 Kenworth K-303-28

1/2-13 UNC: max. 35 lbft  
 1 5/16-12 UNF: max. 35 lbft

### 99-10 P 861 (BK)

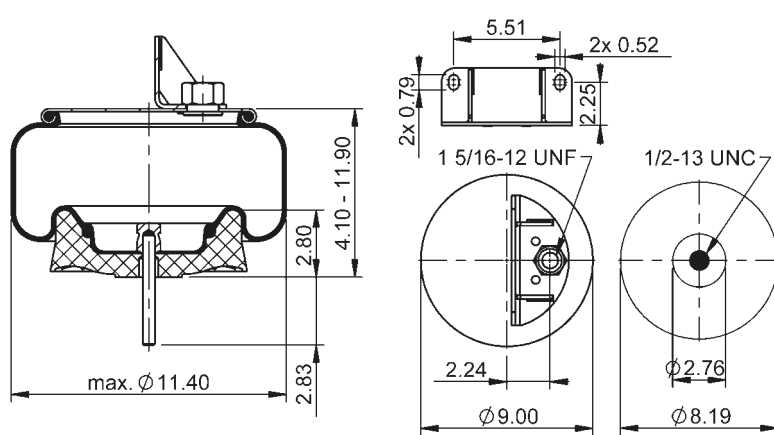

68357



**lb** 12.2 lb **No.** 9311561

**Cross-reference | Cruce de Referencia**  
 Firestone W01-358-9541

**Manufacturer | Fabricante**  
 Kenworth C81-1005

1/2-13 UNC: max. 35 lbft  
 1 5/16-12 UNF: max. 35 lbft

### 99-10 P 862 (BK)

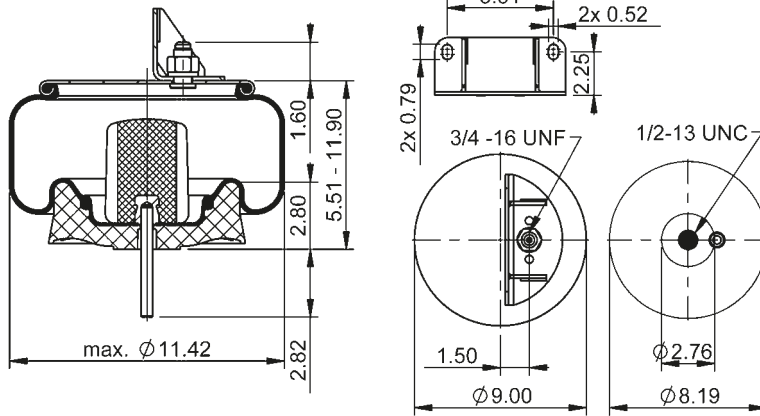

69657



**lb** 11.1 lb **No.** 9311561

**Cross-reference | Cruce de Referencia**  
 Firestone W01-358-9618  
 Goodyear 1R11-220

**Manufacturer | Fabricante**  
 Kenworth K-303-19

1/2-13 UNC: max. 35 lb-ft  
 3/4-16 UNF: max. 50 lb-ft

### 99L-10 P 1150

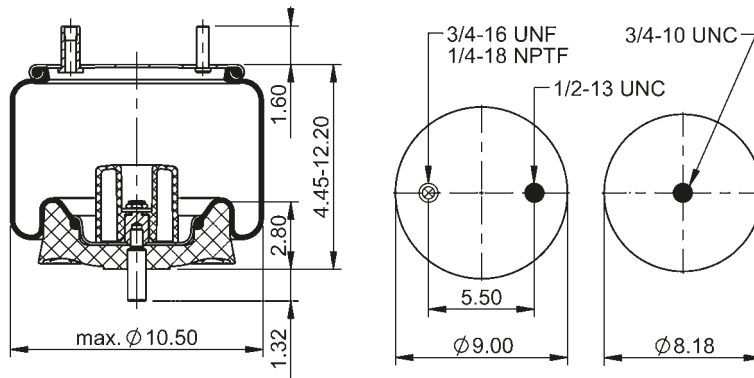

74843



**lb** 13.0 lb **No.** 9308623

**Cross-reference | Cruce de Referencia**  
 Firestone W01-358-5770  
 Goodyear 1R10-101

**Manufacturer | Fabricante**  
 MCI 393902468  
 Ridewell 1003535770C  
 Watson & Chalin AS-0042

1/4-18 NPTF: max. 22 lb-ft  
 1/2-13 UNC: max. 35 lb-ft  
 3/4-10 UNC: max. 50 lb-ft

### 99L-10 P 1594

**new**

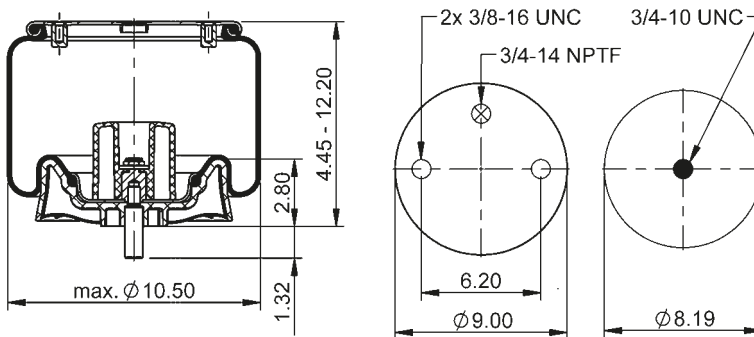

601536



**lb** 10.1 lb **No.** 9311561

**Cross-reference | Cruce de Referencia**  
 Firestone W01-358-5748

3/4-10 UNC: max. 50 lb-ft  
 3/4-14 NPTF: max. 22 lb-ft

### 99-12 P 206

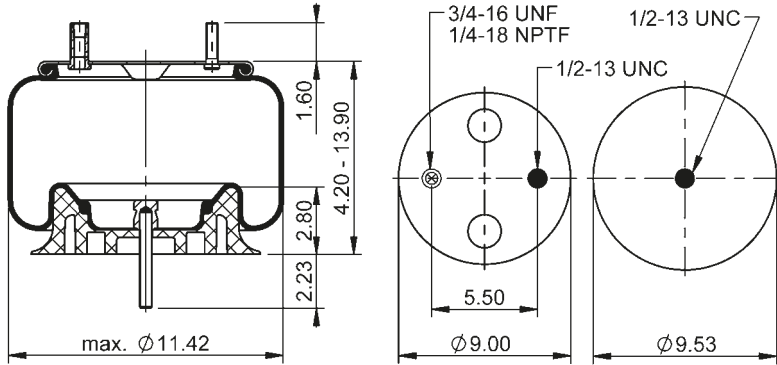

69627



**lb** 9.3 lb **No.** 9308127

**Cross-reference | Cruce de Referencia**

Firestone W01-358-9565  
Goodyear 1R12-324

**Manufacturer | Fabricante**

Navistar/Fleetrite 2027912C1

1/4-18 NPTF: max. 22 lbft  
1/2-13 UNC: max. 35 lbft  
3/4-16 UNF: max. 50 lbft

### 99-12 P 314

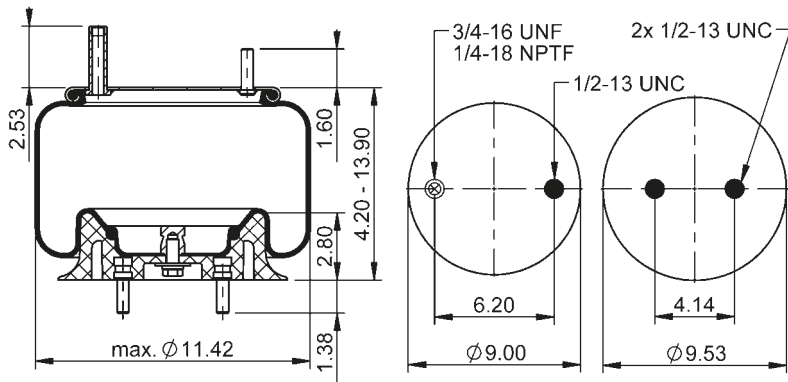

64255



**lb** 9.5 lb **No.** 9308624

**Cross-reference | Cruce de Referencia**

Firestone W01-358-9422  
Goodyear 1R11-028

**Manufacturer | Fabricante**

Hendrickson S-13032  
Kenworth K-303-6  
K-303-14  
K-303-15  
Navistar/Fleetrite 554762C1  
SAF Holland 57009422  
Watson & Chalin AS-0017  
Volvo 85101148  
and more

1/4-18 NPTF: max. 22 lbft  
1/2-13 UNC: max. 35 lbft  
3/4-16 UNF: max. 50 lbft

### 99-12 A 334

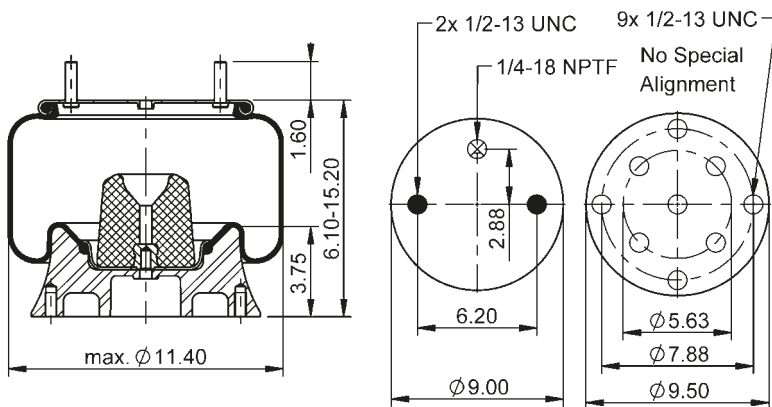

64360



**lb** 15.5 lb **No.** 9309183

**Cross-reference | Cruce de Referencia**

Firestone W01-358-9075

**Manufacturer | Fabricante**

Brake & Wheel M3536  
Hutchens H-2007  
Ridewell 1003589075C  
SAF Holland 90557030

1/4-18 NPTF: max. 22 lbft  
1/2-13 UNC: max. 35 lbft



### 99-12 P 379

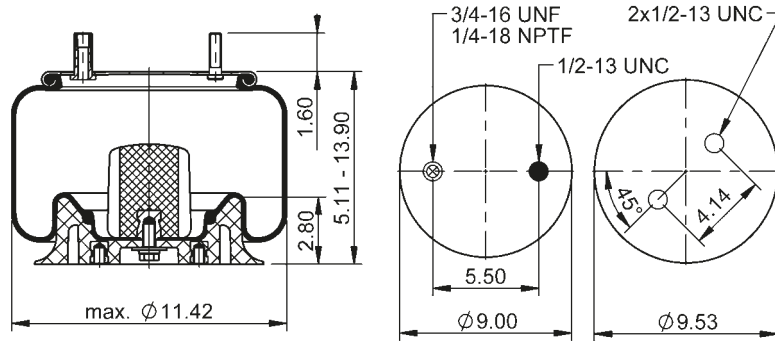

64361



**lb** 11.5 lb **No.** 9308625

**Cross-reference | Cruce de Referencia**

Firestone	W01-358-9379
Goodyear	1R12-178

**Manufacturer | Fabricante**

Loadguard	SC2110
Navistar/Fleetrite	1660694C1
SAF Holland	57009379

- 1/4-18 NPTF: max. 22 lb-ft
- 1/2-13 UNC: max. 35 lb-ft
- 3/4-16 UNF: max. 50 lb-ft

### 99-12 P 401

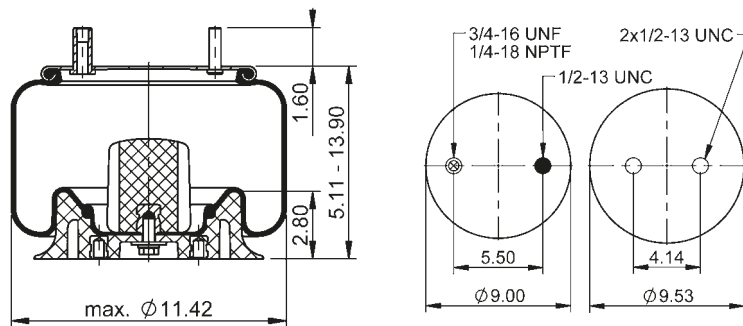

64362



**lb** 11.5 lb **No.** 9308625

**Cross-reference | Cruce de Referencia**

Firestone	W01-358-8900
Goodyear	1R11-204

**Manufacturer | Fabricante**

Reyco	17361-01
Watson & Chalin	AS-0143

- 1/4-18 NPTF: max. 22 lb-ft
- 1/2-13 UNC: max. 35 lb-ft
- 3/4-16 UNF: max. 50 lb-ft

### 99-12 P 447

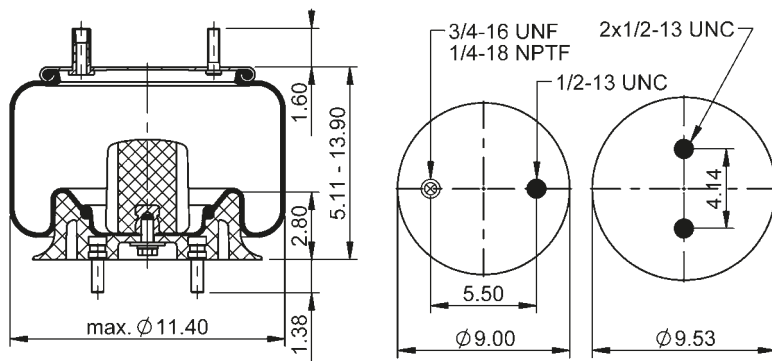

64363



**lb** 11.7 lb **No.** 9308624

**Cross-reference | Cruce de Referencia**

Firestone	W01-358-9378
Goodyear	1R11-202

**Manufacturer | Fabricante**

Ridewell	1003589378C
----------	-------------

- 1/4-18 NPTF: max. 22 lb-ft
- 1/2-13 UNC: max. 35 lb-ft
- 3/4-16 UNF: max. 50 lb-ft

### 99-12 P 464

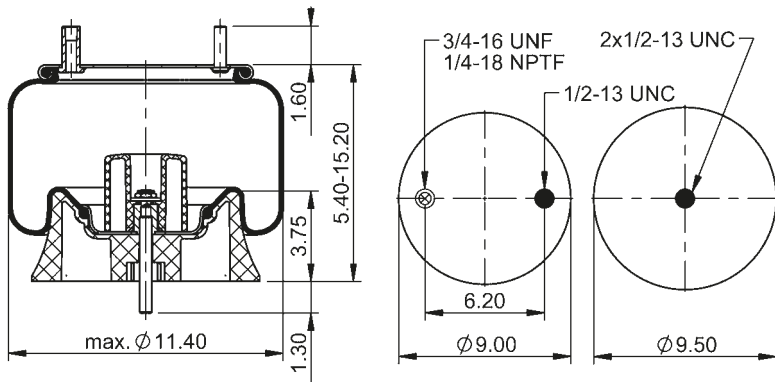

### 64364



**lb** 10.3 lb **No.** 9311939

#### Cross-reference | Cruce de Referencia

Firestone	W01-358-8901
Goodyear	1R11-149

#### Manufacturer | Fabricante

Ridewell	1003588901C
----------	-------------

- 1/4-18 NPTF: max. 22 lb-ft
- 1/2-13 UNC: max. 35 lb-ft
- 3/4-16 UNF: max. 50 lb-ft

### 99-12 P 477

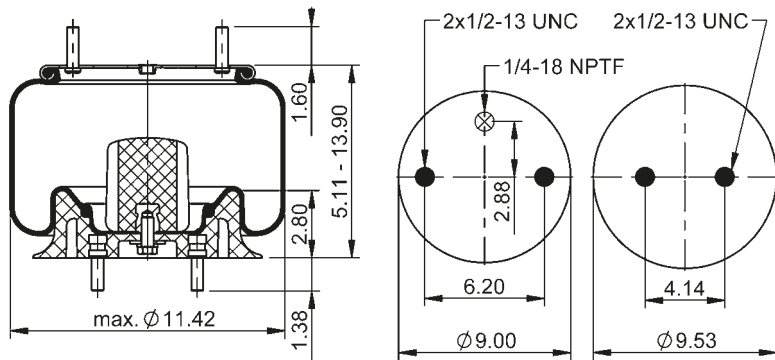

### 64365



**lb** 11.6 lb **No.** 9308624

#### Cross-reference | Cruce de Referencia

Firestone	W01-358-9376
Goodyear	1R11-200

#### Manufacturer | Fabricante

Monaco Coach	8108
	8619
	14002

- 1/4-18 NPTF: max. 22 lb-ft
- 1/2-13 UNC: max. 35 lb-ft

### 99-12 P 478

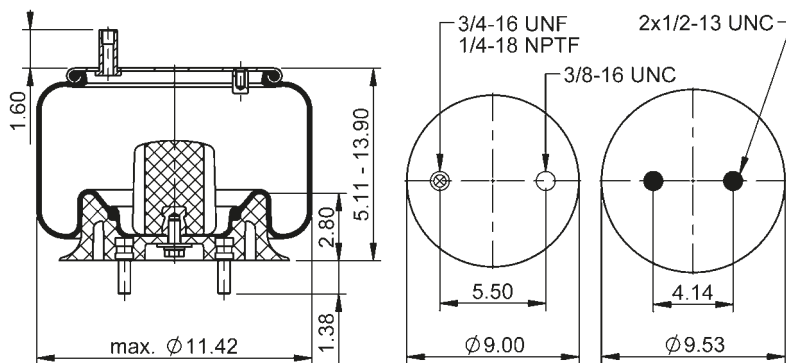

### 64366



**lb** 11.6 lb **No.** 9308624

#### Cross-reference | Cruce de Referencia

Firestone	W01-358-9377
Goodyear	1R11-201

#### Manufacturer | Fabricante

Reyco	21054-01
-------	----------

- 1/4-18 NPTF: max. 22 lb-ft
- 1/2-13 UNC: max. 35 lb-ft
- 3/4-16 UNF: max. 50 lb-ft

### 99-12 P 479

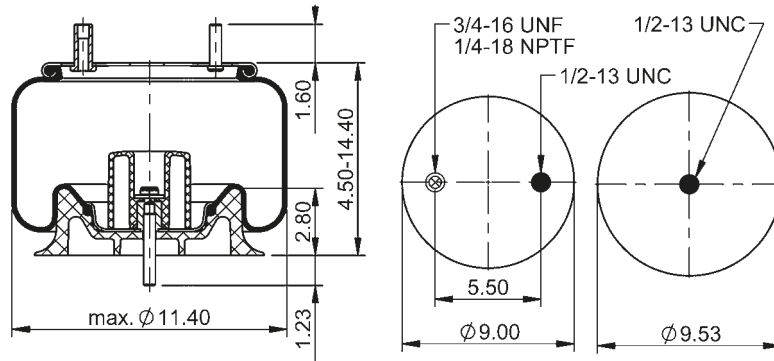

64367



**lb** 9.8 lb **No.** 9308127

**Cross-reference | Cruce de Referencia**

Firestone	W01-358-9387
Goodyear	1R11-159
	1R11-203

**Manufacturer | Fabricante**

Ridwell	1003589387C
---------	-------------

1/4-18 NPTF: max. 22 lb-ft  
 1/2-13 UNC: max. 35 lb-ft  
 3/4-16 UNF: max. 50 lb-ft

### 99-12 P 515

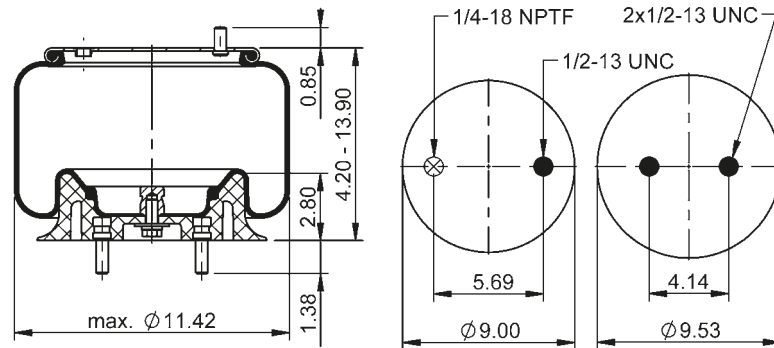

64256



**lb** 9.4 lb **No.** 9308624

**Cross-reference | Cruce de Referencia**

Firestone	W01-358-9616
Goodyear	1R11-242

**Manufacturer | Fabricante**

Kenworth	K-303-16
----------	----------

1/4-18 NPTF: max. 22 lb-ft  
 1/2-13 UNC: max. 35 lb-ft

### 99-12 P 516

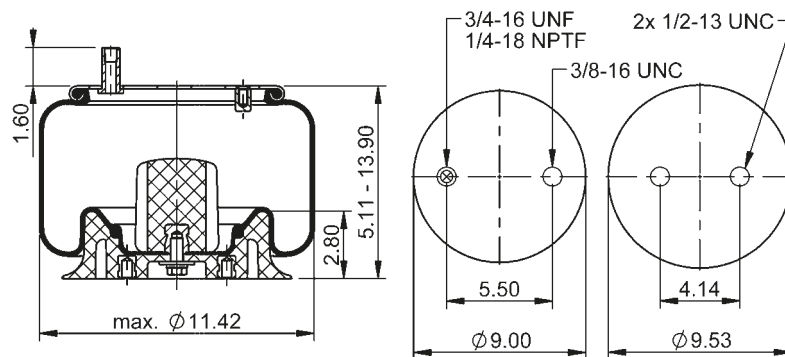

64368



**lb** 11.4 lb **No.** 9308625

**Cross-reference | Cruce de Referencia**

Firestone	W01-358-9476
Goodyear	1R11-205

**Manufacturer | Fabricante**

Tuthill	20446-01
---------	----------

1/4-18 NPTF: max. 22 lb-ft  
 1/2-13 UNC: max. 35 lb-ft  
 3/4-16 UNF: max. 50 lb-ft

### 99-12 P 524

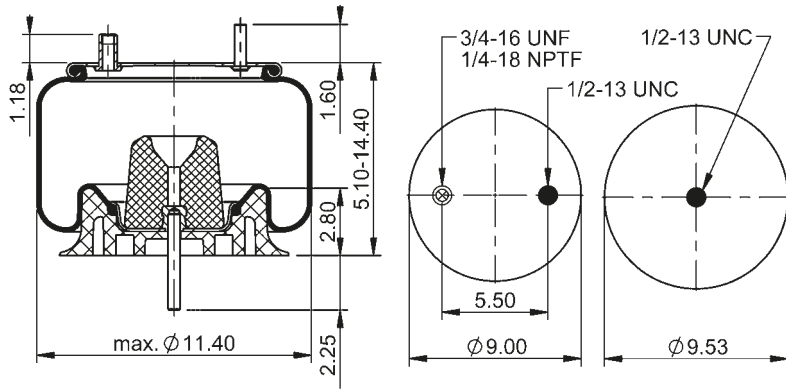

64369



**lb** 11.3 lb **No.** 9308127

**Manufacturer | Fabricante**  
Raydan 211-00-040

- 1/4-18 NPTF: max. 22 lb-ft
- 1/2-13 UNC: max. 35 lb-ft
- 3/4-16 UNF: max. 50 lb-ft

### 99-12 P 563

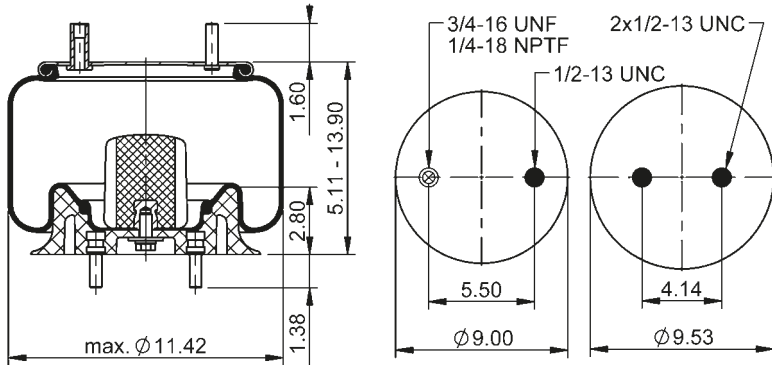

64286



**lb** 11.7 lb **No.** 9308624

**Cross-reference | Cruce de Referencia**  
Firestone W01-358-9448  
Goodyear 1R11-150

**Manufacturer | Fabricante**  
Eldorado Bus 7089  
Ridewell 1003589448C

- 1/4-18 NPTF: max. 22 lb-ft
- 1/2-13 UNC: max. 35 lb-ft
- 3/4-16 UNF: max. 50 lb-ft

### 99-12 P 705

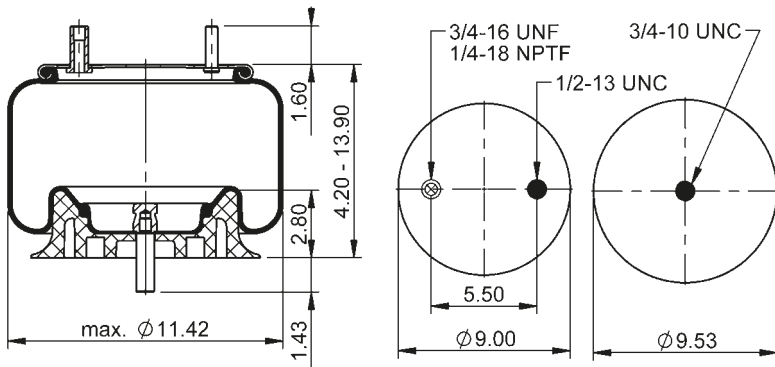

64627



**lb** 9.3 lb **No.** 9308623

**Cross-reference | Cruce de Referencia**  
Firestone W01-358-9421  
Goodyear 1R11-171

**Manufacturer | Fabricante**  
American Carrier 8003-003  
Brake & Wheel M3547  
Ridewell 1003589421C  
SAF Holland 57009421  
TOYO TRL200E  
Tuthill 6429

- 1/4-18 NPTF: max. 22 lb-ft
- 1/2-13 UNC: max. 35 lb-ft
- 3/4-10 UNC: max. 50 lb-ft

### 99-12 P 730

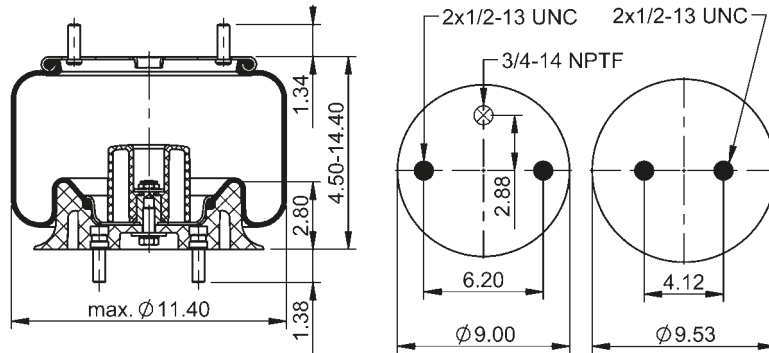

64664



**lb** 10.3 lb **No.** 9308624

**Cross-reference | Cruce de Referencia**  
Firestone W01-358-8897

**Manufacturer | Fabricante**  
Monaco Coach 0180 4591

1/2-13 UNC: max. 35 lb-ft  
3/4-14 NPTF: max. 22 lb-ft

### 99-12 P 757

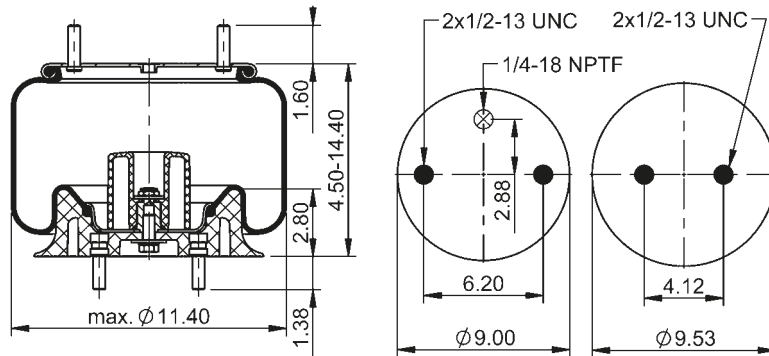

64701



**lb** 10.5 lb **No.** 9308624

**Manufacturer | Fabricante**  
Monaco Coach 0180 7467

1/4-18 NPTF: max. 22 lb-ft  
1/2-13 UNC: max. 35 lb-ft

### 99-12 P 786

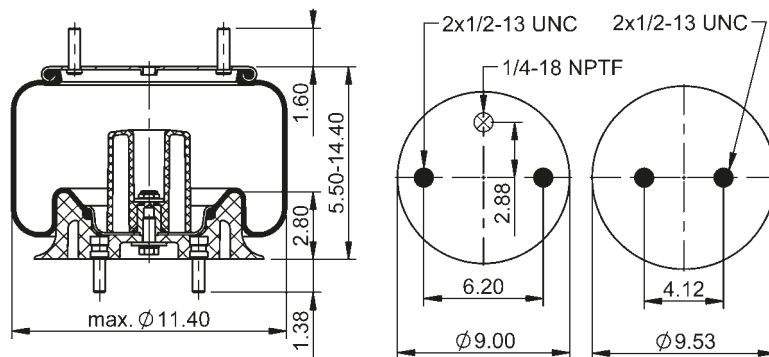

64752

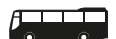

**lb** 10.8 lb **No.** 9308624

**Manufacturer | Fabricante**  
Monaco Coach 0180 8670

1/4-18 NPTF: max. 22 lb-ft  
1/2-13 UNC: max. 35 lb-ft

### 99-12 P 835

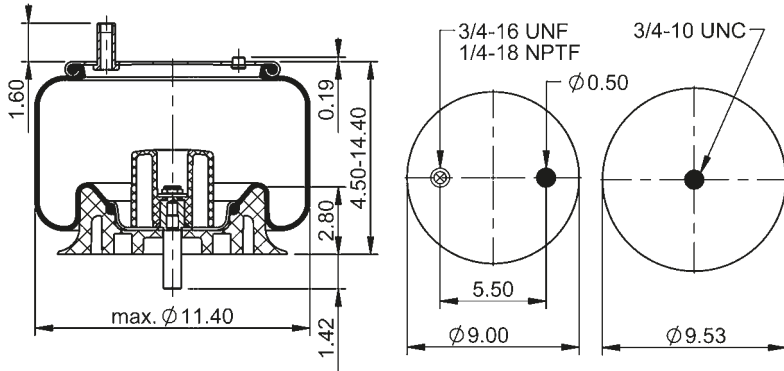

65908



**lb** 10.3 lb **No.** 9308623

**Manufacturer | Fabricante**  
SAF Holland 90557361

**1/4-18 NPTF:** max. 22 lb-ft  
**3/4-10 UNC:** max. 50 lb-ft  
**3/4-16 UNF:** max. 50 lb-ft

### 99-12 P 937 (BK)

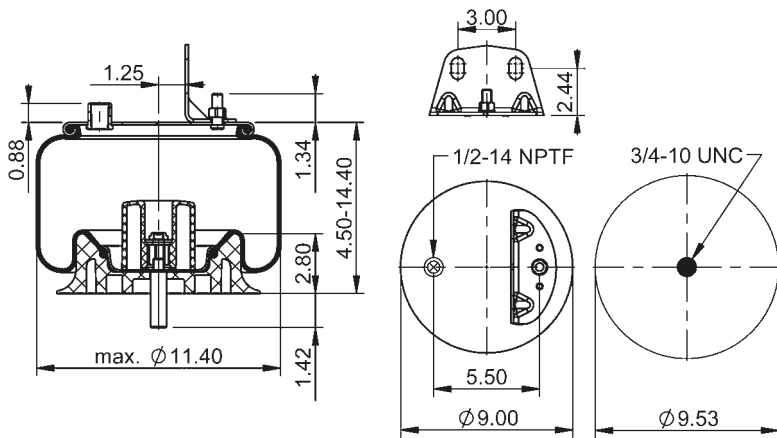

68675



**lb** 11.9 lb **No.** 9308623

**Manufacturer | Fabricante**  
SAF Holland 90557411

**1/2-13 UNC:** max. 35 lb-ft  
**1/2-14 NPTF:** max. 22 lb-ft  
**3/4-10 UNC:** max. 50 lb-ft

### 99-12 P 974

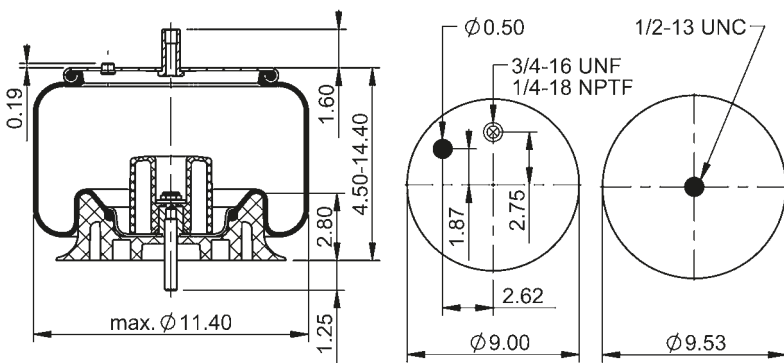

67870



**lb** 9.8 lb **No.** 9308127

**Manufacturer | Fabricante**  
SAF Holland 90557371

**1/4-18 NPTF:** max. 22 lb-ft  
**1/2-13 UNC:** max. 35 lb-ft  
**3/4-16 UNF:** max. 50 lb-ft

### 99-12 P 1155

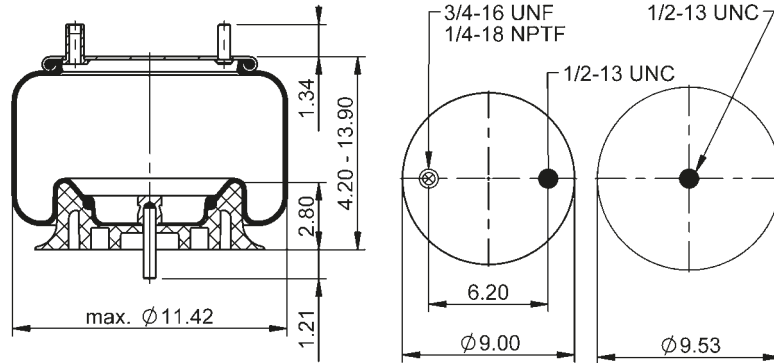

74911



**lb** 9.3 lb **No.** 9308127

**Cross-reference | Cruce de Referencia**  
 Firestone W01-653-9446  
 Goodyear 1R12-156

**Manufacturer | Fabricante**  
 MCI 2K-3-11  
 Prevost 63-0179

1/4-18 NPTF: max. 22 lb-ft  
 1/2-13 UNC: max. 35 lb-ft  
 3/4-16 UNF: max. 50 lb-ft

### 99-12 P 1292

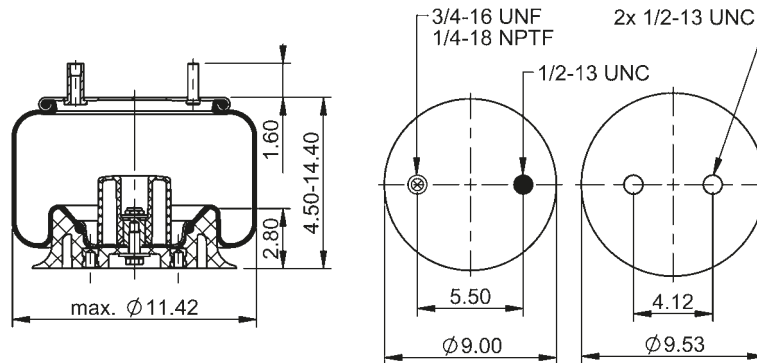

77432



**lb** 10.4 lb **No.** 9308625

**Cross-reference | Cruce de Referencia**  
 Firestone W01-358-9650  
 Goodyear 1R11-225

**Manufacturer | Fabricante**  
 SAF Holland 90557097

1/4-18 NPTF: max. 22 lb-ft  
 1/2-13 UNC: max. 35 lb-ft  
 3/4-16 UNF: max. 50 lb-ft

### 99-12 P 1476

**new**

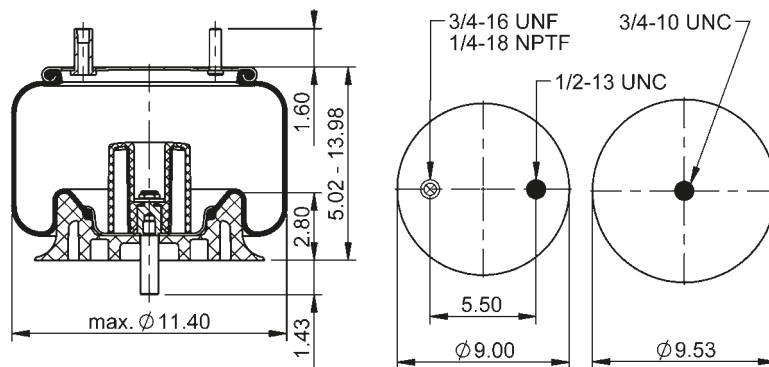

79614



**lb** 4.7 lb **No.** 9308623

**Cross-reference | Cruce de Referencia**  
 Firestone W01-358-5766  
 Goodyear 1R11-161

**Manufacturer | Fabricante**  
 American Carrier 8003-023  
 Hutchens 19141-01

1/4-18 NPTF: max. 22 lb-ft  
 1/2-13 UNC: max. 35 lb-ft  
 3/4-10 UNC: max. 50 lb-ft

### 99K-12 P 093

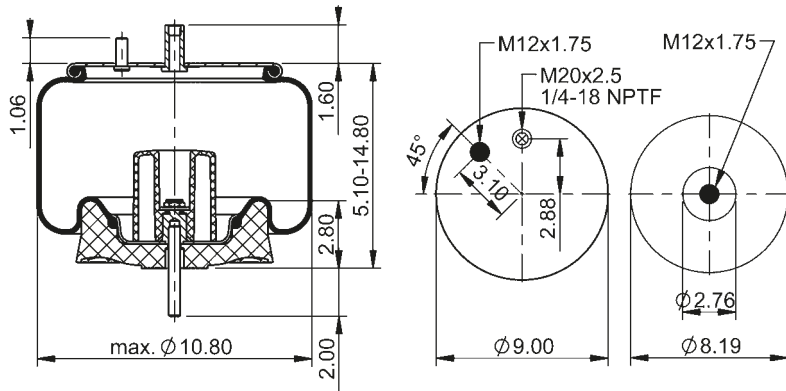

68608



**lb** 10.9 lb **No.** 9311561

**Cross-reference | Cruce de Referencia**  
Firestone W01-358-9554

**Manufacturer | Fabricante**  
Hendrickson 60716-2  
Mack 57QL59M  
Volvo 20462941

1/4-18 NPTF: max. 22 lb-ft

### 99K-12 P 100

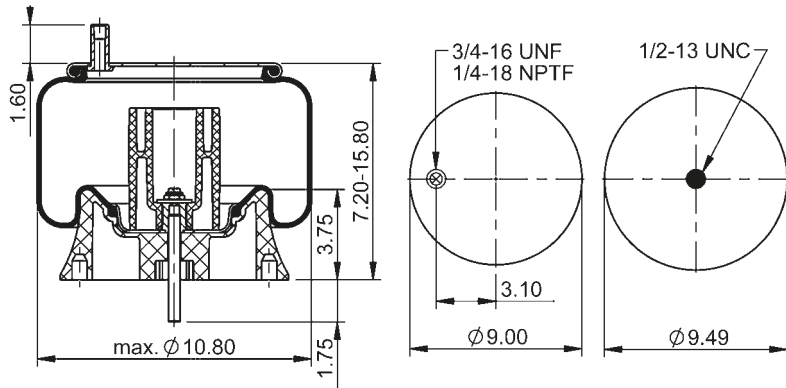

68617



**lb** 12.2 lb **No.** 9311939

**Cross-reference | Cruce de Referencia**  
Firestone W01-358-8959

**Manufacturer | Fabricante**  
Reyco 20773-01

1/4-18 NPTF: max. 22 lb-ft  
1/2-13 UNC: max. 35 lb-ft  
3/4-16 UNF: max. 50 lb-ft

### 99K-12 P 790

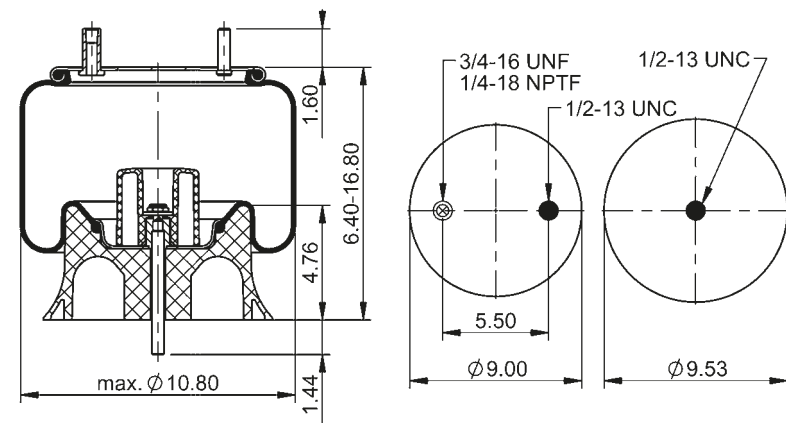

64754



**lb** 11.6 lb **No.** 9308128

**Manufacturer | Fabricante**  
SAF Holland 90557346

1/4-18 NPTF: max. 22 lb-ft  
1/2-13 UNC: max. 35 lb-ft  
3/4-16 UNF: max. 50 lb-ft



### 99M-13 P 1156

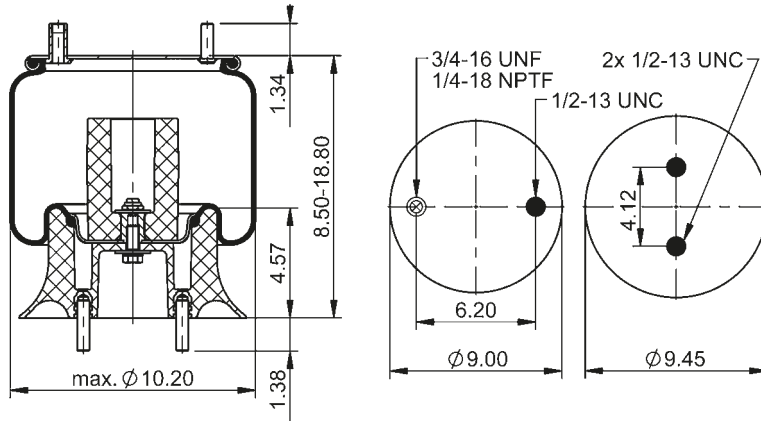

75007



**lb** 13.7 lb **No.** 9317208

**Cross-reference | Cruce de Referencia**  
 Firestone W01-358-9539

1/4-18 NPTF: max. 22 lbft  
 1/2-13 UNC: max. 35 lbft  
 3/4-16 UNF: max. 50 lbft

### 99M-13 P 1181

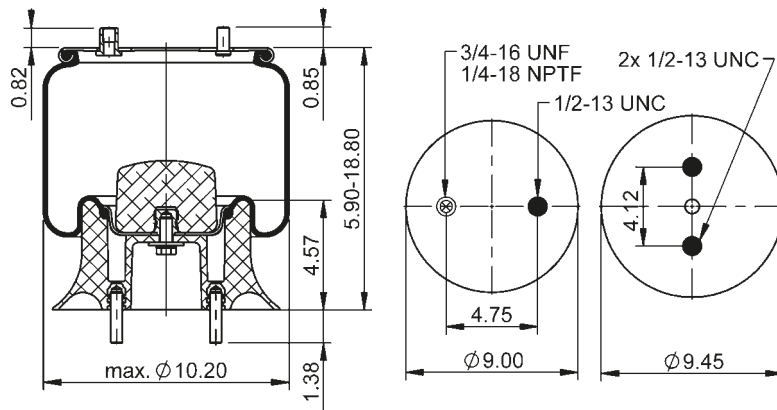

75179



**lb** 12.1 lb **No.** 9317208

**Cross-reference | Cruce de Referencia**  
 Firestone W01-358-9073  
 Goodyear 1R12-028

**Manufacturer | Fabricante**  
 Bluebird 990671  
 Flexible 6336212  
 Hendrickson S-7193  
 S-13040  
 Kenworth K-102-A  
 Prevost 630045  
 Ridewell 1003589073C  
 SAF Holland 57009073  
 and more

1/4-18 NPTF: max. 22 lbft  
 1/2-13 UNC: max. 35 lbft  
 3/4-16 UNF: max. 50 lbft

### 99M-13 P 1182

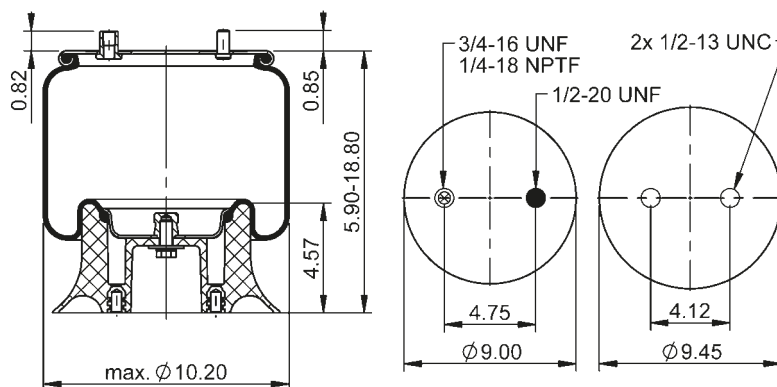

75180



**lb** 10.4 lb **No.** 9317208

**Cross-reference | Cruce de Referencia**  
 Firestone W01-358-9652

**Manufacturer | Fabricante**  
 Hendrickson S-14147  
 Mack 57QL1115  
 Scania 660251

1/4-18 NPTF: max. 22 lbft  
 1/2-13 UNC: max. 35 lbft  
 3/4-16 UNF: max. 50 lbft

### 99M-13 P 1196

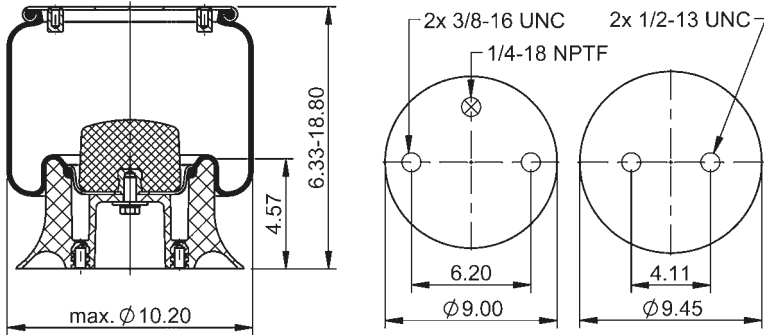

### 75412

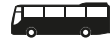

**lb** 13.2 lb **No.** 9317208

**Cross-reference | Cruce de Referencia**  
 Firestone W01-358-9049  
 Goodyear 1R10-036

**Manufacturer | Fabricante**  
 Tuthill 6252

1/4-18 NPTF: max. 22 lb-ft  
 3/8-16 UNC: max. 18 lb-ft  
 1/2-13 UNC: max. 50 lb-ft

### 99M-13 P 1197

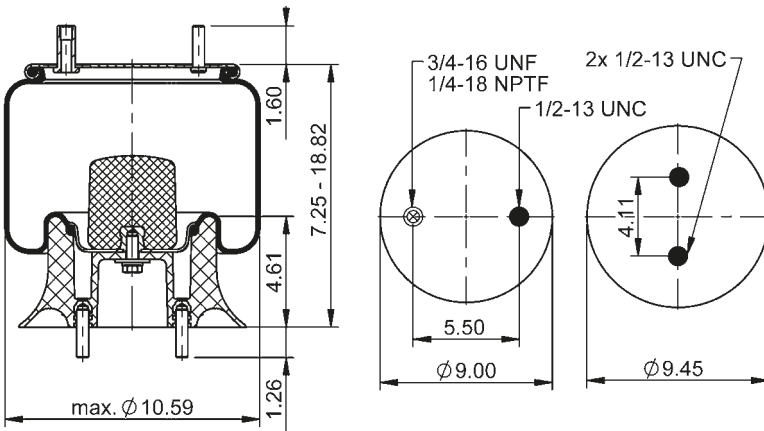

### 75410



**lb** 13.3 lb **No.** 9317208

**Cross-reference | Cruce de Referencia**  
 Goodyear 1R11-119

1/4-18 NPTF: max. 22 lb-ft  
 1/2-13 UNC: max. 35 lb-ft  
 3/4-16 UNF: max. 50 lb-ft

### 99M-13 P 1283

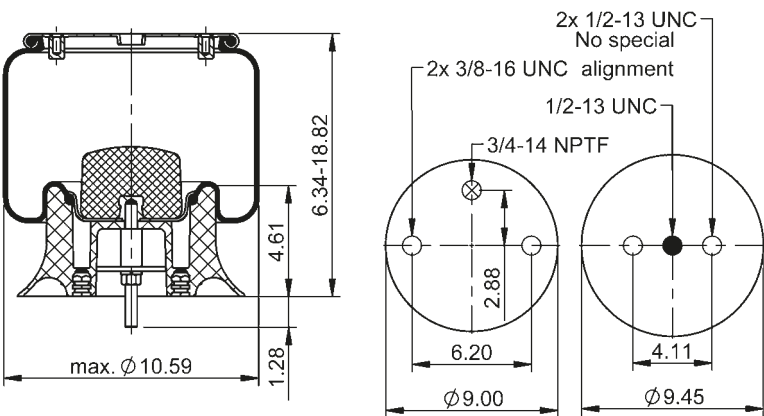

### 77202



**lb** 12.8 lb **No.** 9317208

**Cross-reference | Cruce de Referencia**  
 Firestone W01-358-8478

**Manufacturer | Fabricante**  
 Peterbilt 301686  
 308424

3/8-16 UNC: max. 18 lb-ft  
 1/2-13 UNC: max. 35 lb-ft  
 3/4-14 NPTF: max. 22 lb-ft

### 99M-13 P 1290

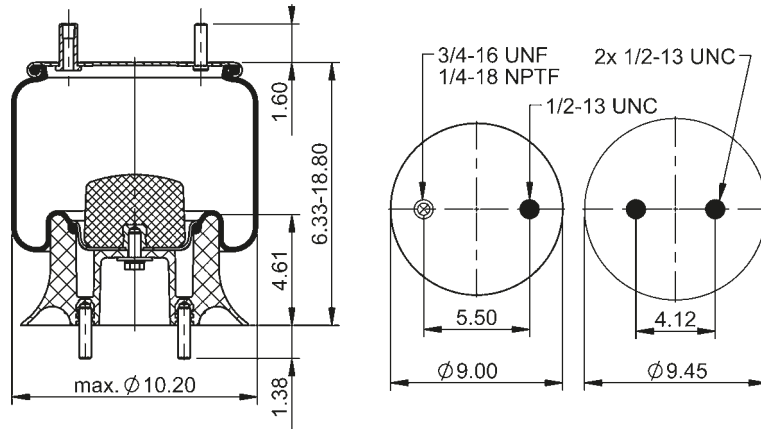

77427



**lb** 12.4 lb **No.** 9317208

**Cross-reference | Cruce de Referencia**  
 Firestone W01-358-9290

**Manufacturer | Fabricante**  
 American Carrier 8003-025  
 Ridewell 1003589290C

1/4-18 NPTF: max. 22 lbft  
 1/2-13 UNC: max. 35 lbft  
 3/4-16 UNF: max. 50 lbft

### 99-14 P 053

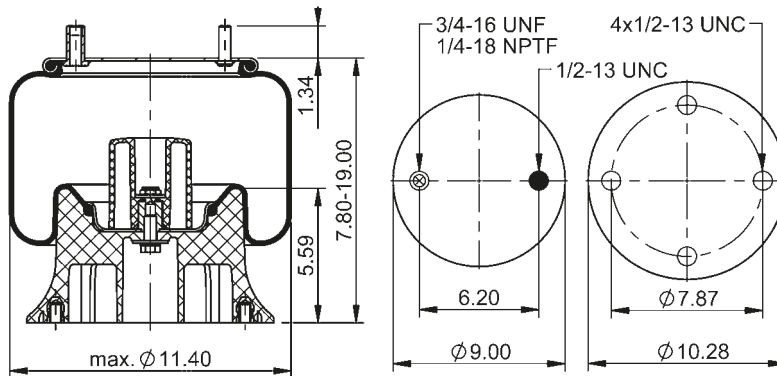

68355



**lb** 12.2 lb **No.** 9308133

**Manufacturer | Fabricante**  
 Orion 80131522

1/4-18 NPTF: max. 22 lbft  
 1/2-13 UNC: max. 35 lbft  
 3/4-16 UNF: max. 50 lbft

### 99-14 P 191

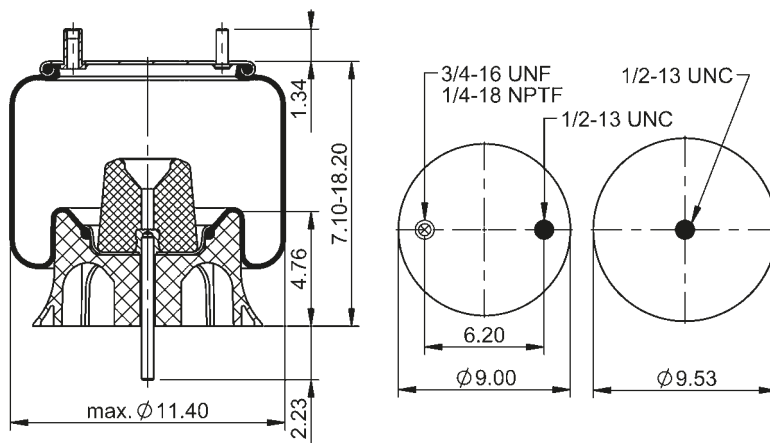

69511



**lb** 13.1 lb **No.** 9308128

**Cross-reference | Cruce de Referencia**  
 Firestone W01-W35-8497

**Manufacturer | Fabricante**  
 New Flyer 303734

1/4-18 NPTF: max. 22 lbft  
 1/2-13 UNC: max. 35 lbft  
 3/4-16 UNF: max. 50 lbft

### 99-14 P 322

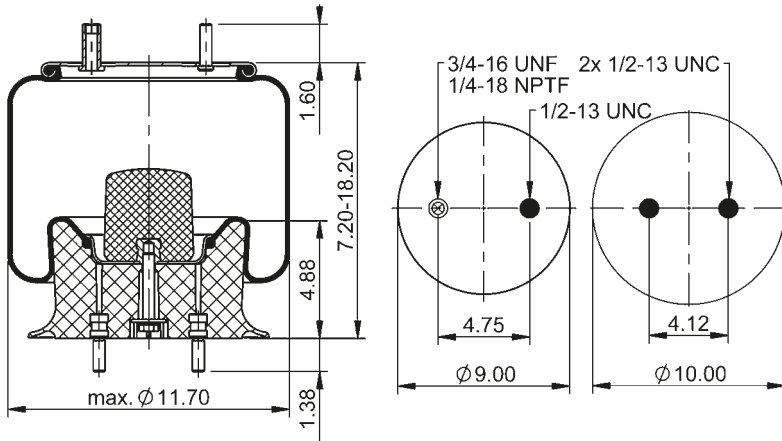

64378



**lb** 15.6 lb **No.** 9314115

**Cross-reference | Cruce de Referencia**

Firestone	W01-358-9415
Goodyear	1R11-018

**Manufacturer | Fabricante**

Hendrickson	B-7193 S-13040
Kenworth	K-303-5
Loadguard	SC2049
Navistar/Fleetrite	554761C1
Ridewell	1003589415C
SAF Holland	57009415
Dayton	352-9415

1/4-18 NPTF: max. 22 lb-ft  
 1/2-13 UNC: max. 35 lb-ft  
 3/4-16 UNF: max. 50 lb-ft

### 99-14 A 337

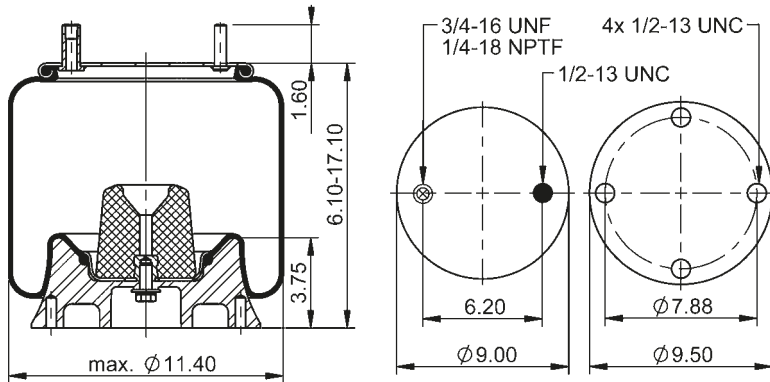

64379



**lb** 15.9 lb **No.** 9309183

**Cross-reference | Cruce de Referencia**

Firestone	W01-358-9439
Goodyear	1R11-039

**Manufacturer | Fabricante**

Mahowk	53-14006-002
--------	--------------

1/4-18 NPTF: max. 22 lb-ft  
 1/2-13 UNC: max. 35 lb-ft  
 3/4-16 UNF: max. 50 lb-ft

### 99-14 P 517

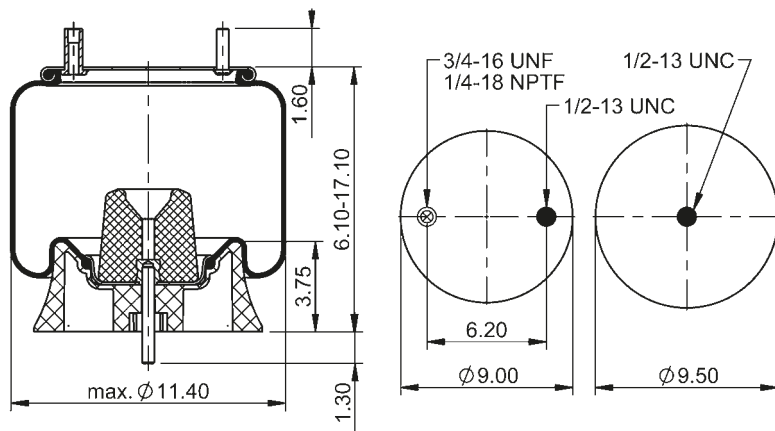

64381



**lb** 12.1 lb **No.** 9311939

**Cross-reference | Cruce de Referencia**

Firestone	W01-358-8919
Goodyear	1R11-191

**Manufacturer | Fabricante**

Ridewell	1003588919C
Silent Drive	AS-8919

1/4-18 NPTF: max. 22 lb-ft  
 1/2-13 UNC: max. 35 lb-ft  
 3/4-16 UNF: max. 50 lb-ft

### 99-14 P 708

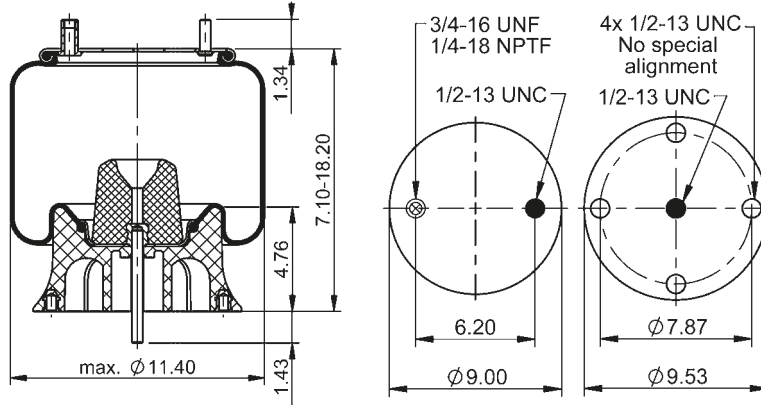

64631



**lb** 12.3 lb **No.** 9308301

**Cross-reference | Cruce de Referencia**  
 Firestone W01-W35-9465  
 Goodyear 1R11-179

**Manufacturer | Fabricante**  
 New Flyer 99865

1/4-18 NPTF: max. 22 lb-ft  
 1/2-13 UNC: max. 35 lb-ft  
 3/4-16 UNF: max. 50 lb-ft

### 99-14 P 737

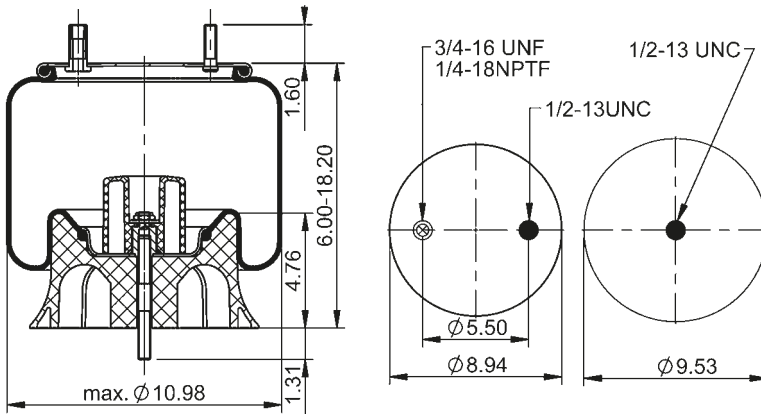

78232



**lb** 12.3 lb **No.** 9308128

**Manufacturer | Fabricante**  
 SAF Holland 90557322

1/4-18 NPTF: max. 22 lb-ft  
 1/2-13 UNC: max. 35 lb-ft  
 3/4-16 UNF: max. 50 lb-ft

### 99-14 P 768

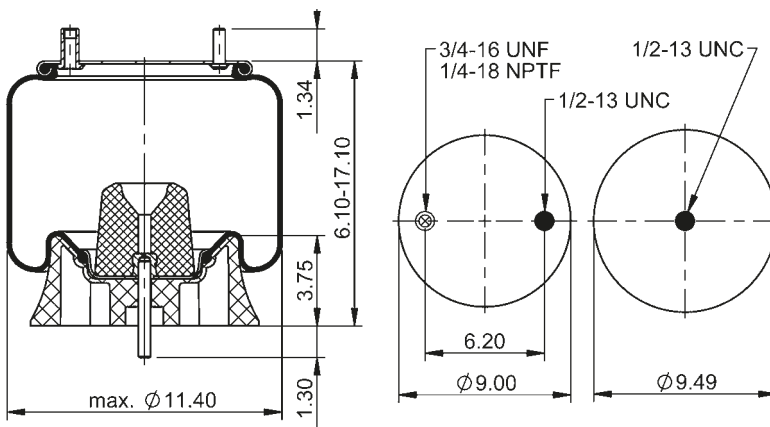

64714



**lb** 12.1 lb **No.** 9311939

**Manufacturer | Fabricante**  
 Link 1103-0505

1/4-18 NPTF: max. 22 lb-ft  
 1/2-13 UNC: max. 35 lb-ft  
 3/4-16 UNF: max. 50 lb-ft

### 99-14 P 895

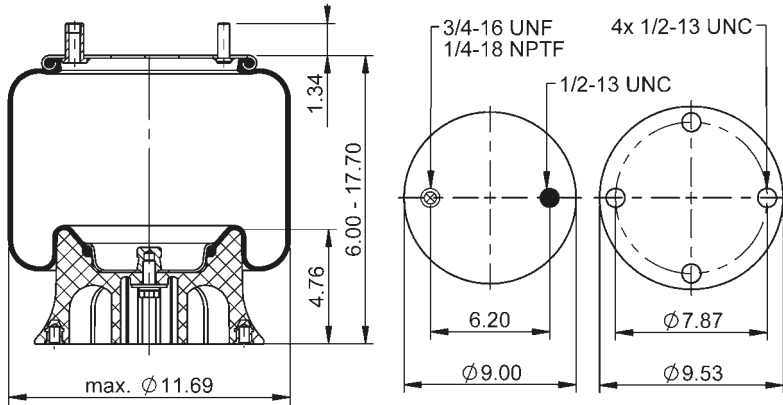

67492



**lb** 11.4 lb **No.** 9308301

**Cross-reference | Cruce de Referencia**  
 Firestone W01-W35-9385  
 Goodyear 1R11-178

**Manufacturer | Fabricante**  
 New Flyer 55089

1/4-18 NPTF: max. 22 lb-ft  
 1/2-13 UNC: max. 35 lb-ft  
 3/4-16 UNF: max. 50 lb-ft

### 99-14 P 1094

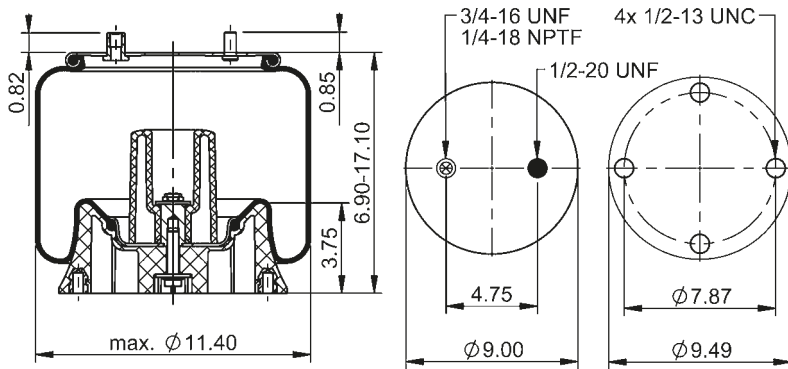

74328



**lb** 12.0 lb **No.** 9312070

**Cross-reference | Cruce de Referencia**  
 Firestone W01-358-8943

1/4-18 NPTF: max. 22 lb-ft  
 1/2-13 UNC: max. 35 lb-ft  
 3/4-16 UNF: max. 50 lb-ft

### 99-14 P 1142

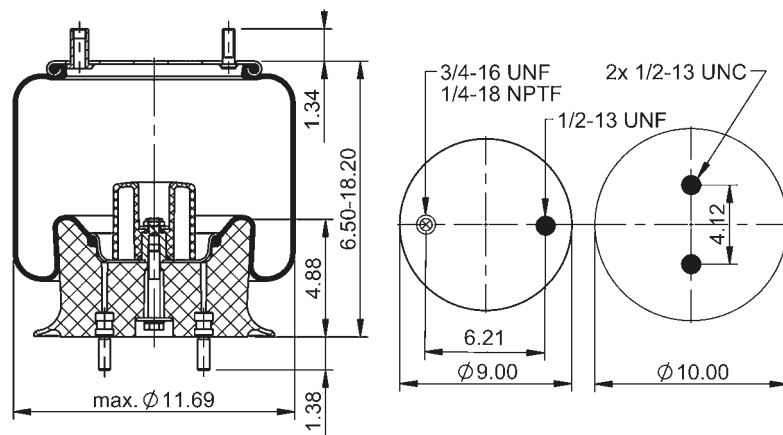

74767



**lb** 13.9 lb **No.** 9314115

**Cross-reference | Cruce de Referencia**  
 Firestone W01-W35-9468

**Manufacturer | Fabricante**  
 New Flyer 102221

1/4-18 NPTF: max. 22 lb-ft  
 1/2-13 UNC: max. 35 lb-ft  
 3/4-16 UNF: max. 50 lb-ft

### 99-14 P 1144

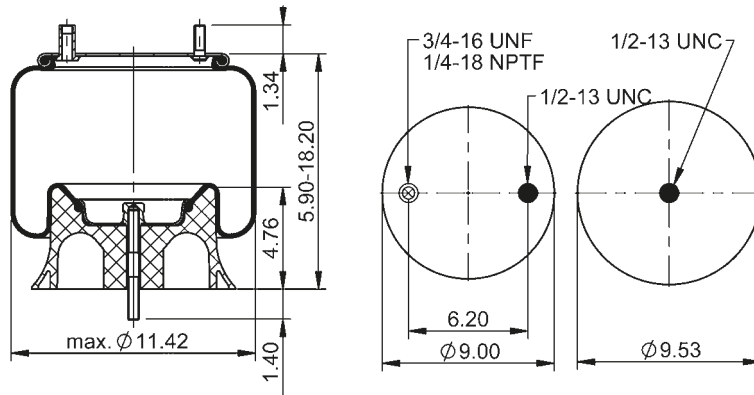

74769



**lb** 11.2 lb **No.** 9308128

**Cross-reference | Cruce de Referencia**  
Firestone W01-W35-8953

**Manufacturer | Fabricante**  
New Flyer 200555

1/4-18 NPTF: max. 22 lb-ft  
1/2-13 UNC: max. 35 lb-ft  
3/4-16 UNF: max. 50 lb-ft

### 99-14 P 1146

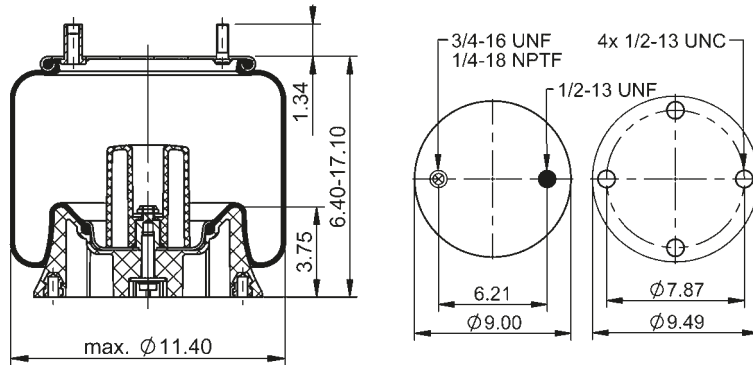

74791



**lb** 11.6 lb **No.** 9312070

**Cross-reference | Cruce de Referencia**  
Firestone W01-358-9441  
Goodyear 1R11-121

**Manufacturer | Fabricante**  
Flxible 6-336-200  
Gillig 538212  
5313187  
5314006  
Novabus N16374

1/4-18 NPTF: max. 22 lb-ft  
1/2-13 UNC: max. 35 lb-ft  
3/4-16 UNF: max. 50 lb-ft

### 99-14 P 1308

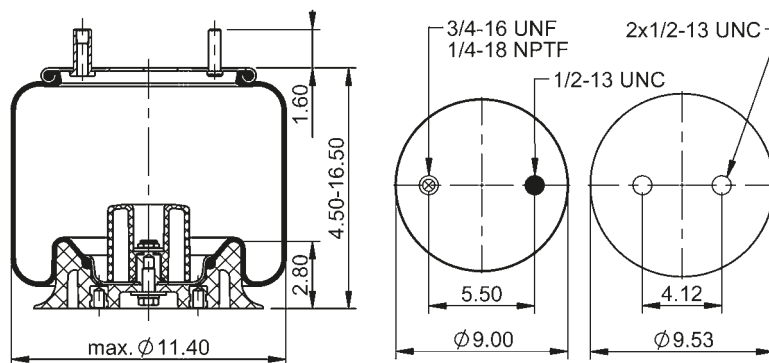

77705



**lb** 12.3 lb **No.** 9308625

**Cross-reference | Cruce de Referencia**  
Goodyear 1R11-241

1/4-18 NPTF: max. 18 lb-ft  
1/2-13 UNC: max. 35 lb-ft  
3/4-16 UNF: max. 50 lb-ft

### 99-14 P 1319

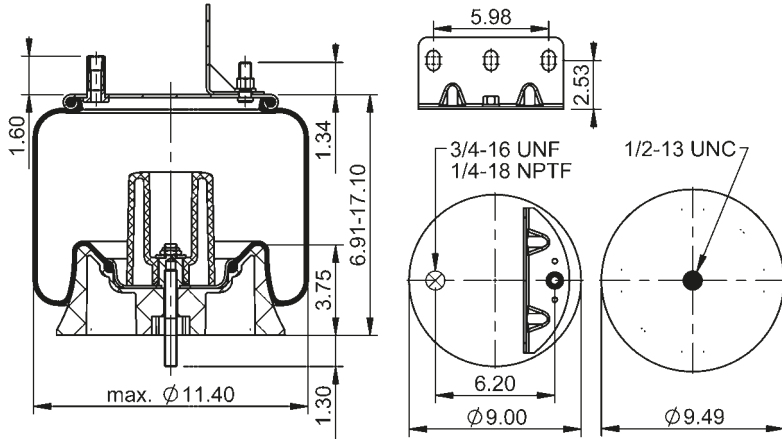

77797

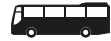

**lb** 13.5 lb **No.** 9311939

**Cross-reference | Cruce de Referencia**  
Firestone W01-358-8942

**Manufacturer | Fabricante**  
Hendrickson 58983-2

- 1/4-18 NPTF: max. 22 lb-ft
- 1/2-13 UNC: max. 35 lb-ft
- 3/4-16 UNF: max. 50 lb-ft

### 99K-15 P 049

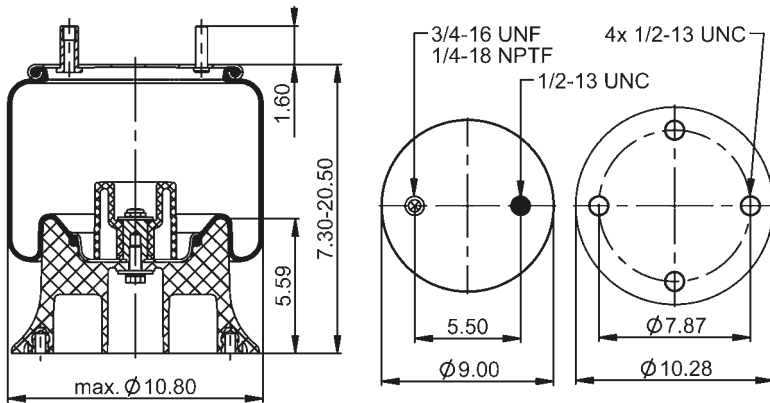

68406



**lb** 12.8 lb **No.** 9308133

**Manufacturer | Fabricante**  
Reyco 710442-01

- 1/4-18 NPTF: max. 22 lb-ft
- 1/2-13 UNC: max. 35 lb-ft
- 3/4-16 UNF: max. 50 lb-ft

### 99K-15 P 079

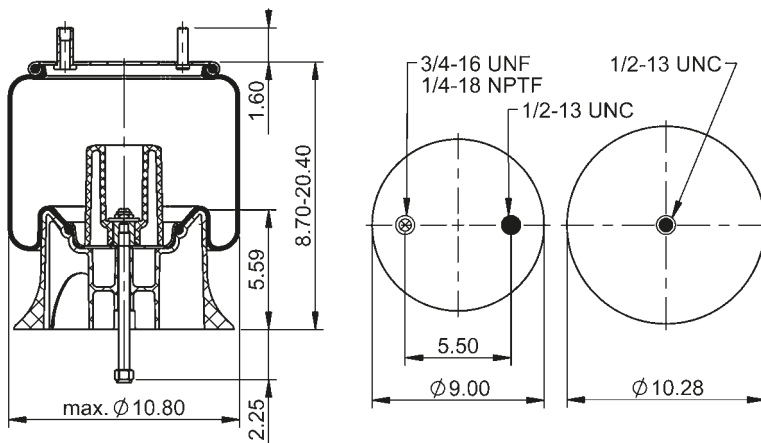

68407



**lb** 14.1 lb **No.** 9314552

**Manufacturer | Fabricante**  
Reyco 710387-02

- 1/4-18 NPTF: max. 22 lb-ft
- 1/2-13 UNC: max. 35 lb-ft
- 3/4-16 UNF: max. 50 lb-ft



### 99K-15 P 417

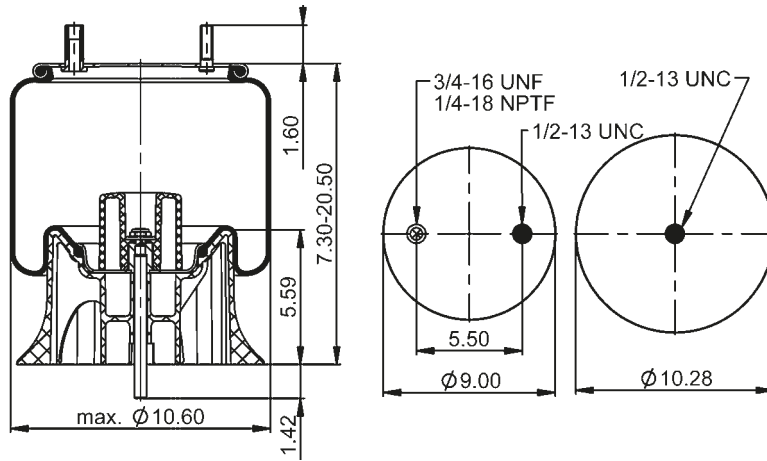

64386



**lb** 12.7 lb **No.** 9314552

**Cross-reference | Cruce de Referencia**  
 Firestone W01-358-9295  
 Goodyear 1R11-166

**Manufacturer | Fabricante**  
 Brake & Wheel M3544  
 Reyco 710387-01  
 SAF Holland 90557121  
 Watson & Chalin AS-0171

1/4-18 NPTF: max. 22 lb-ft  
 1/2-13 UNC: max. 35 lb-ft  
 3/4-16 UNF: max. 50 lb-ft

### 99K-15 P 423

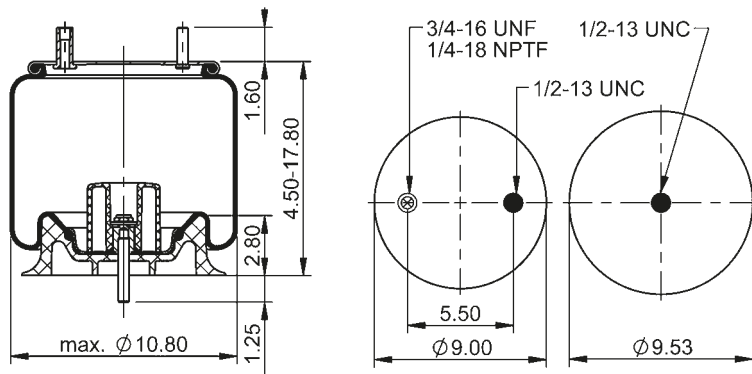

64387



**lb** 10.9 lb **No.** 9308127

**Cross-reference | Cruce de Referencia**  
 Firestone W01-358-9294  
 Goodyear 1R11-915

**Manufacturer | Fabricante**  
 SAF Holland 90557127

1/4-18 NPTF: max. 22 lb-ft  
 1/2-13 UNC: max. 35 lb-ft  
 3/4-16 UNF: max. 50 lb-ft

### 99K-15 P 424

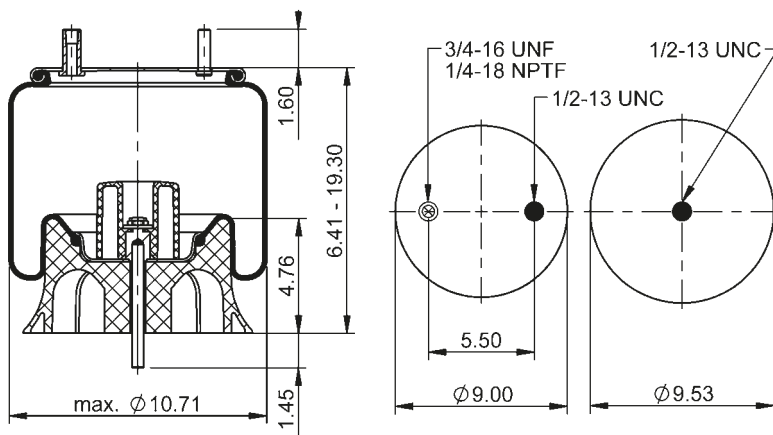

64388



**lb** 12.4 lb **No.** 9308128

**Cross-reference | Cruce de Referencia**  
 Firestone W01-358-9293  
 Goodyear 1R10-120

**Manufacturer | Fabricante**  
 SAF Holland 90557120

1/4-18 NPTF: max. 22 lb-ft  
 1/2-13 UNC: max. 35 lb-ft  
 3/4-16 UNF: max. 50 lb-ft

### 9 9K-15 P 425

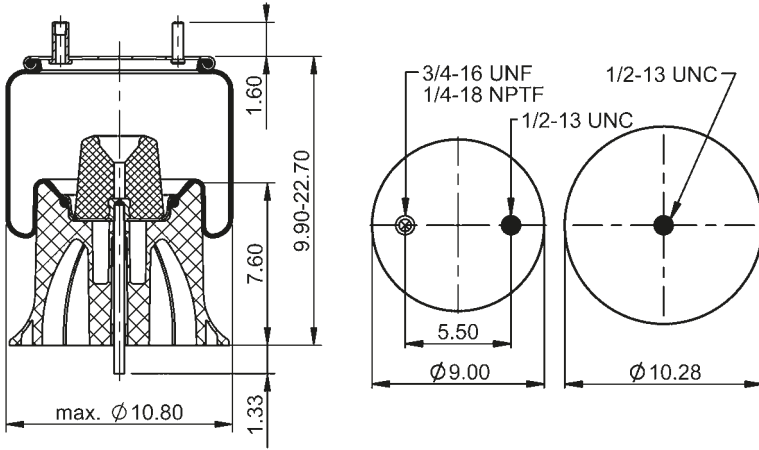

64389



**lb** 16.1 lb **No.** 9306248

**Cross-reference | Cruce de Referencia**

Firestone W01-358-9291  
Goodyear 1R10-122

**Manufacturer | Fabricante**

SAF Holland 90557122  
90557139

- 1/4-18 NPTF: max. 22 lb-ft
- 1/2-13 UNC: max. 35 lb-ft
- 3/4-16 UNF: max. 50 lb-ft

### 9 9K-15 P 455

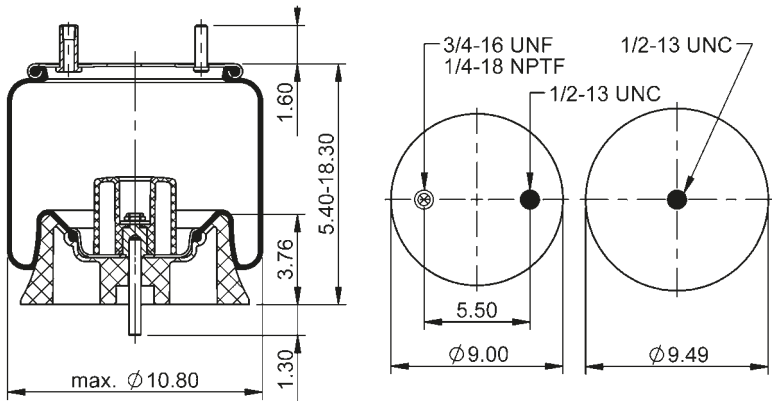

64390



**lb** 11.4 lb **No.** 9311939

**Cross-reference | Cruce de Referencia**

Firestone W01-358-8949

**Manufacturer | Fabricante**

SAF Holland 90557150

- 1/4-18 NPTF: max. 22 lb-ft
- 1/2-13 UNC: max. 35 lb-ft
- 3/4-16 UNF: max. 50 lb-ft

### 9 9K-15 P 945 (BK)

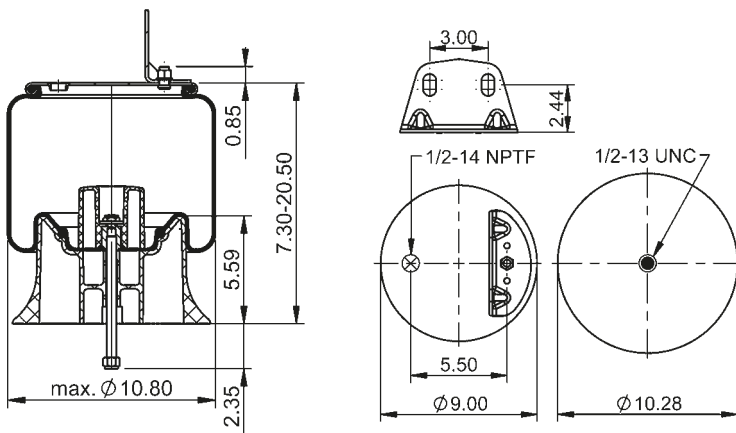

67448



**lb** 15.1 lb **No.** 9314552

**Manufacturer | Fabricante**

Reyco 709668-01

- 1/2-13 UNC: max. 35 lb-ft
- 1/2-14 NPTF: max. 22 lb-ft

### 99K-15 P 1147

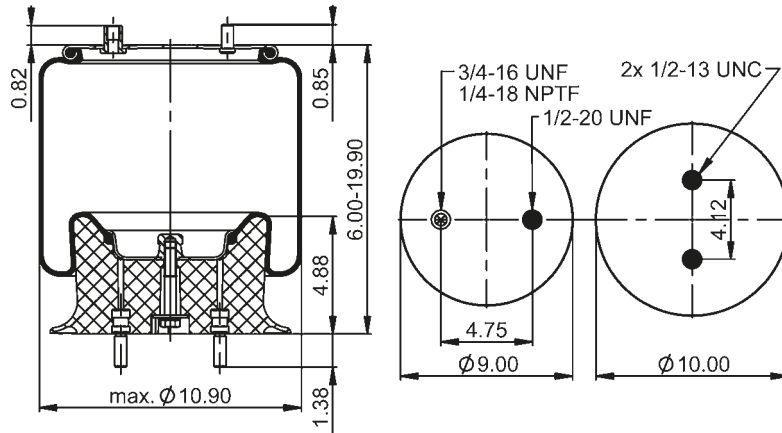

74792



**lb** 12.8 lb **No.** 9314115

**Cross-reference | Cruce de Referencia**

Firestone W01-358-9017  
Goodyear 1R10-089

**Manufacturer | Fabricante**

Flexible 6-304-157  
6-336-174  
6-841-92  
97-240-153  
Hendrickson 98734016  
Novabus G1012381  
Prevost 63-0044  
63-0158

and more

1/4-18 NPTF: max. 22 lb-ft  
1/2-13 UNC: max. 35 lb-ft  
3/4-16 UNF: max. 50 lb-ft

### 99K-15 P 1298

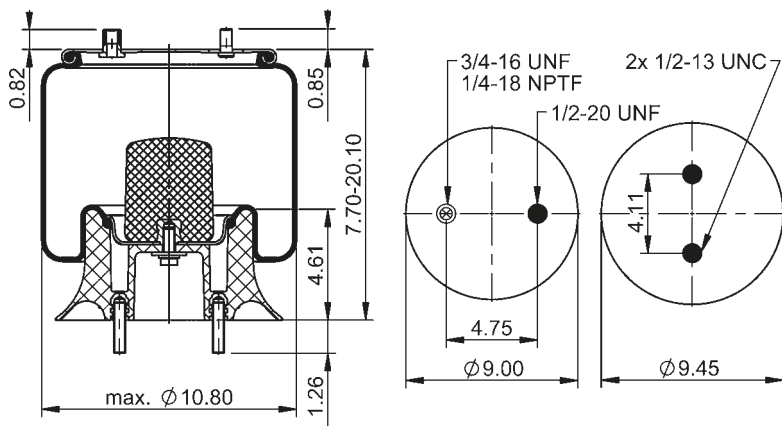

77616



**lb** 13.2 lb **No.** 9317208

**Cross-reference | Cruce de Referencia**

Firestone W01-358-9592  
Goodyear 1R10-133

1/4-18 NPTF: max. 22 lb-ft  
1/2-13 UNC: max. 35 lb-ft  
3/4-16 UNF: max. 50 lb-ft

### 99K-15 P 1299

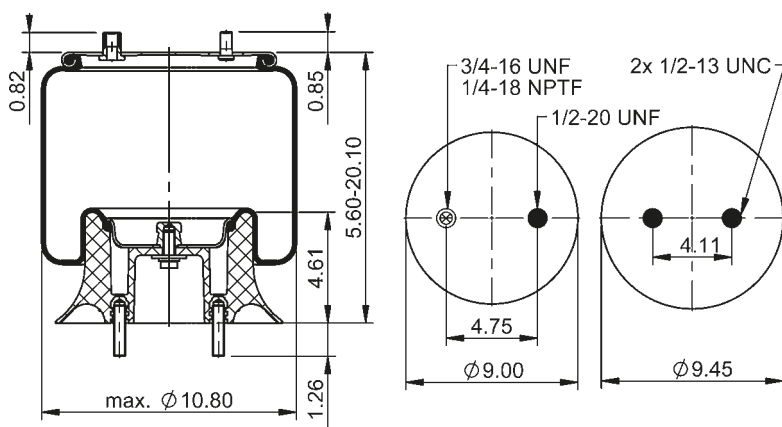

77618



**lb** 11.0 lb **No.** 9317208

**Cross-reference | Cruce de Referencia**

Goodyear 1R10-105

**Manufacturer | Fabricante**

Novabus G1076863

1/4-18 NPTF: max. 22 lb-ft  
1/2-13 UNC: max. 35 lb-ft  
3/4-16 UNF: max. 50 lb-ft

### 99-16 P 568

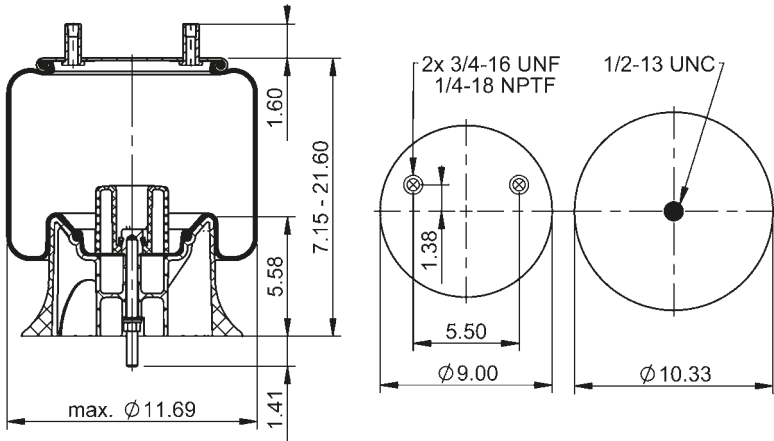

64692



**lb** 12.8 lb **No.** 9314552

**Cross-reference | Cruce de Referencia**  
 Firestone W01-358-9626  
 Goodyear 1R11-292

**Manufacturer | Fabricante**  
 Hendrickson S-23720

**1/4-18 NPTF:** max. 22 lb-ft  
**1/2-13 UNC:** max. 35 lb-ft  
**3/4-16 UNF:** max. 50 lb-ft

### 99K-16 P 1568

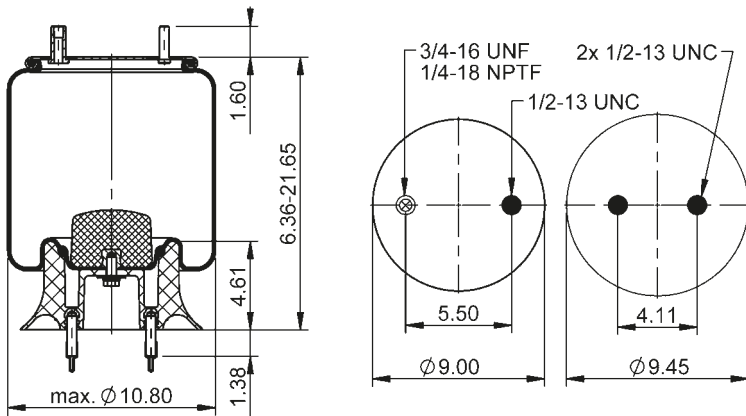

600804



**lb** 12.8 lb **No.** 9317208

**Cross-reference | Cruce de Referencia**  
 Firestone W01-358-8965

**1/8-27 NPTF:** max. 18 lb-ft  
**1/2-13 UNC:** max. 35 lb-ft  
**3/4-16 UNF:** max. 50 lb-ft

### 99A-20 P 1363

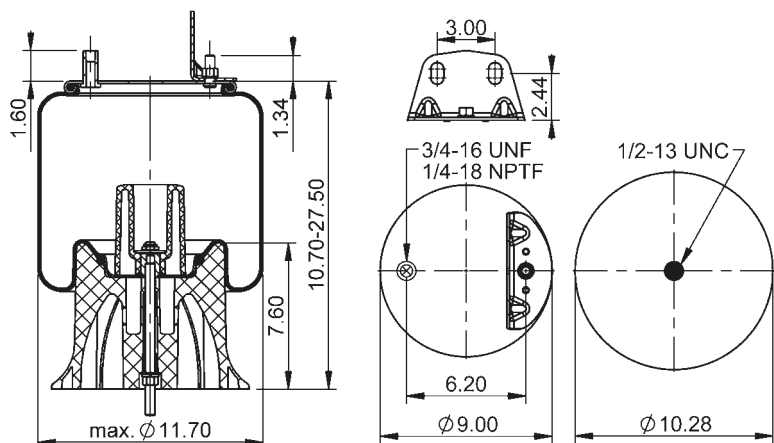

78233



**lb** 16.8 lb **No.** 9306248

**Manufacturer | Fabricante**  
 SAF Holland 90557364

**1/4-18 NPTF:** max. 22 lb-ft  
**1/2-13 UNC:** max. 35 lb-ft  
**3/4-16 UNF:** max. 50 lb-ft

### 99B-20 P 740

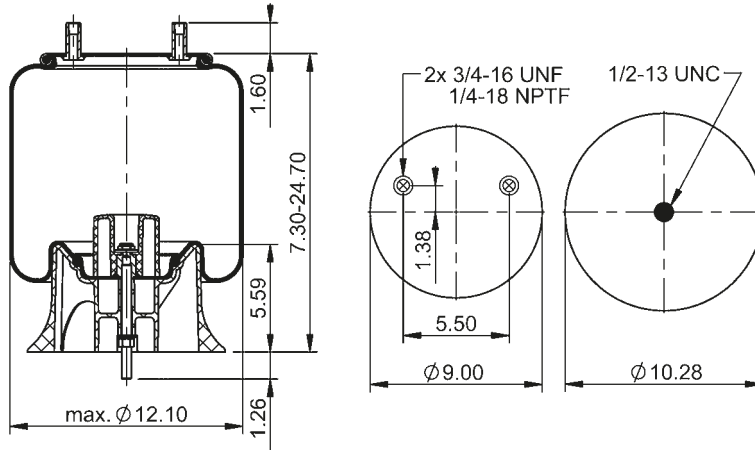

64696



**lb** 13.3 lb **No.** 9314552

**Cross-reference | Cruce de Referencia**  
 Firestone W01-358-9621

**Manufacturer | Fabricante**  
 Hendrickson S-23613

- 1/4-18 NPTF: max. 22 lb-ft
- 1/2-13 UNC: max. 35 lb-ft
- 3/4-16 UNF: max. 50 lb-ft

### 99J-20 P 776

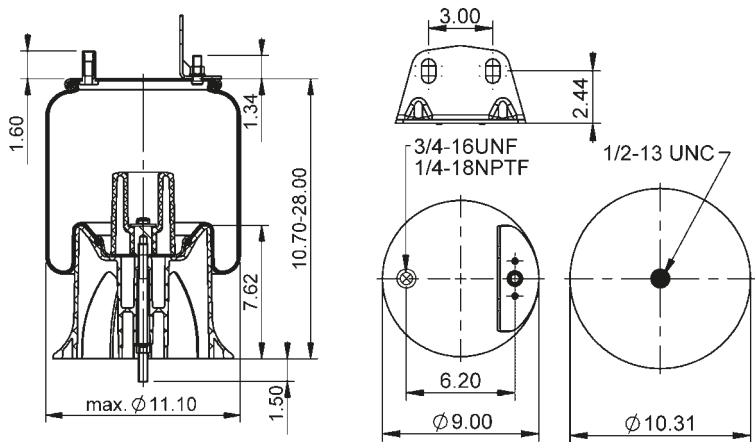

78234



**lb** 15.7 lb **No.** 9306248

**Manufacturer | Fabricante**  
 SAF Holland 90557343

- 1/4-18 NPTF: max. 22 lb-ft
- 1/2-13 UNC: max. 35 lb-ft
- 3/4-16 UNF: max. 50 lb-ft

### 99B-22 P 741

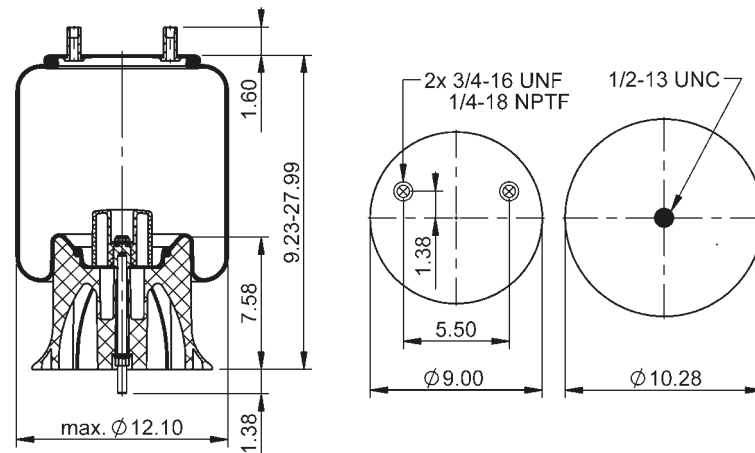

64697



**lb** 15.2 lb **No.** 9306248

**Cross-reference | Cruce de Referencia**  
 Firestone W01-358-9619

**Manufacturer | Fabricante**  
 Hendrickson S-23614

- 1/4-18 NPTF: max. 22 lb-ft
- 1/2-13 UNC: max. 35 lb-ft
- 3/4-16 UNF: max. 50 lb-ft

### 9 10-10 P 204

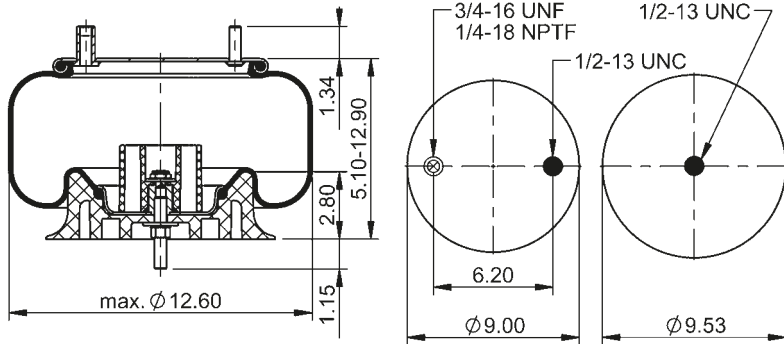

69625



**lb** 10.8 lb **No.** 9308127

**Cross-reference | Cruce de Referencia**  
Firestone W01-358-8971

**Manufacturer | Fabricante**  
Hendrickson 59484-2

1/4-18 NPTF: max. 22 lb-ft  
1/2-13 UNC: max. 35 lb-ft  
3/4-16 UNF: max. 50 lb-ft

### 9 10-10 S 221

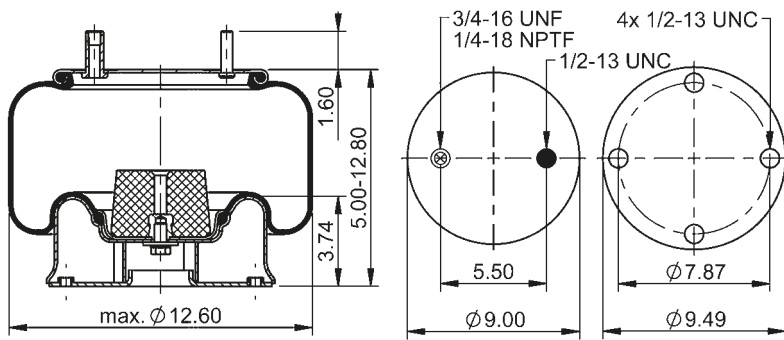

69767



**lb** 12.5 lb **No.** 9311827

**Cross-reference | Cruce de Referencia**  
Firestone W01-358-9249

**Manufacturer | Fabricante**  
Meritor 201150  
2258N1470  
Hendrickson 98734-003  
SAF Holland 90557107  
Suspension Dynamics 55015  
Suspensions, Inc. 201150

1/4-18 NPTF: max. 22 lb-ft  
1/2-13 UNC: max. 35 lb-ft  
3/4-16 UNF: max. 50 lb-ft

### 9 10-10 P 311

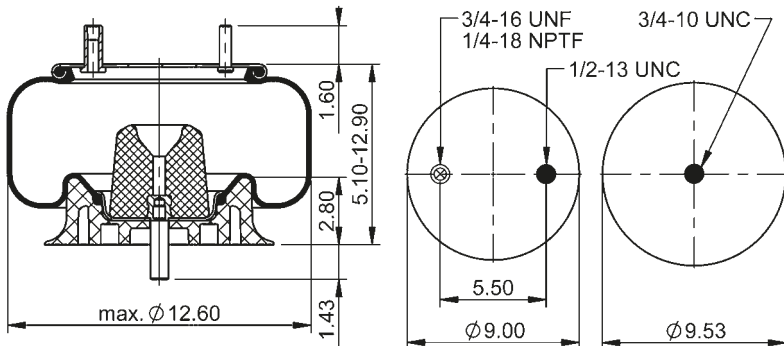

64260



**lb** 13.7 lb **No.** 9308623

**Cross-reference | Cruce de Referencia**  
Firestone W01-358-9039  
Goodyear 1R12-095

**Manufacturer | Fabricante**  
Hendrickson S-2064  
S-11650  
SAF Holland 90557023  
90557085  
Volvo 3130492  
85101153  
Watson & Chalin AS-0012  
Raydan 211-00-010  
and more

1/4-18 NPTF: max. 22 lb-ft  
1/2-13 UNC: max. 35 lb-ft  
3/4-10 UNC: max. 50 lb-ft

### 9 10-10 P 328

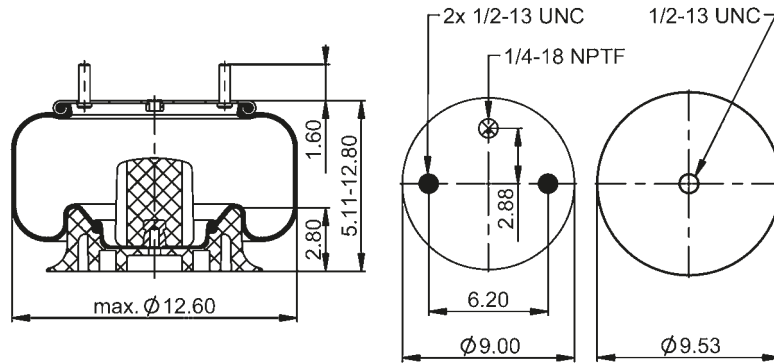

64430



**lb** 11.4 lb **No.** 9308127

**Cross-reference | Cruce de Referencia**

Firestone W01-358-9033  
Goodyear 1R12-351

1/4-18 NPTF: max. 22 lb-ft  
1/2-13 UNC: max. 35 lb-ft

### 9 10-10 P 331

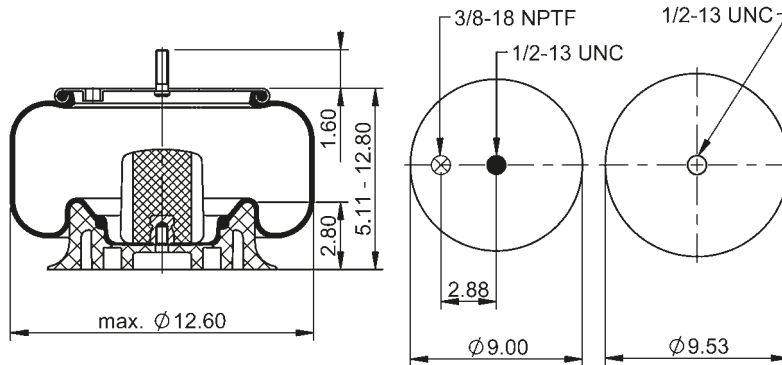

64431



**lb** 11.4 lb **No.** 9308127

**Cross-reference | Cruce de Referencia**

Firestone W01-358-9077  
Goodyear 1R12-359

**Manufacturer | Fabricante**

Fruehauf UCB-44531  
MFR-022354  
Loadguard SC2780  
Ridewell 1003589077C  
SAF Holland 57009077  
Taurus AS500-9077

3/8-18 NPTF: max. 22 lb-ft  
1/2-13 UNC: max. 35 lb-ft

### 9 10-10 P 338

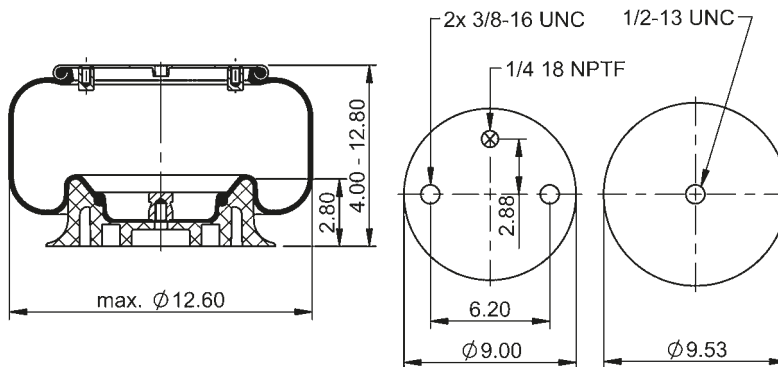

64432



**lb** 9.2 lb **No.** 9308127

1/4-18 NPTF: max. 22 lb-ft  
3/8-16 UNC: max. 20 lb-ft

### 9 10-10 P 339

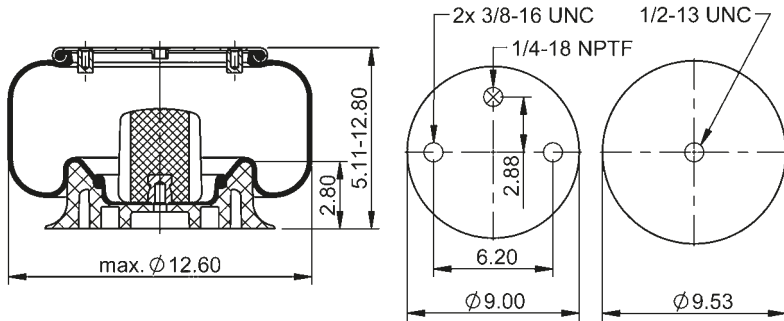

64433

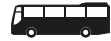

**lb** 11.4 lb **No.** 9308127

**Cross-reference | Cruce de Referencia**

Firestone	W01-358-9031
Goodyear	1R12-350

**Manufacturer | Fabricante**

Flxible	6-379-2
Loadguard	SC2785
Peerless	0550-00051
Ridewell	1003589031C
Taurus	AS500-9031

1/4-18 NPTF: max. 22 lb-ft  
3/8-16 UNC: max. 20 lb-ft

### 9 10-10 P 397

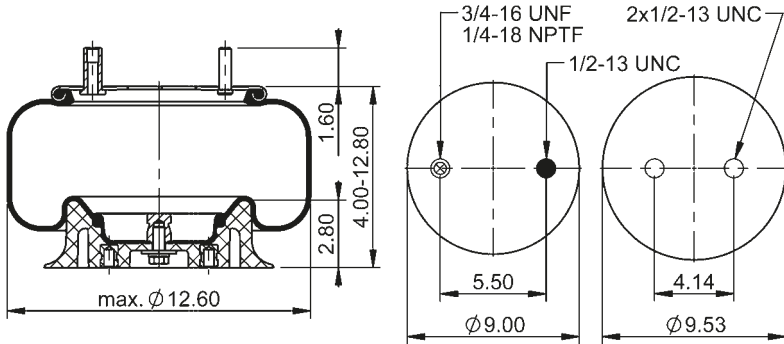

64435



**lb** 12.0 lb **No.** 9308625

**Cross-reference | Cruce de Referencia**

Firestone	W01-358-9332
Goodyear	1R12-561

**Manufacturer | Fabricante**

Reyco	20074-01
-------	----------

1/4-18 NPTF: max. 22 lb-ft  
1/2-13 UNC: max. 35 lb-ft  
3/4-16 UNF: max. 50 lb-ft

### 9 10-10 P 398

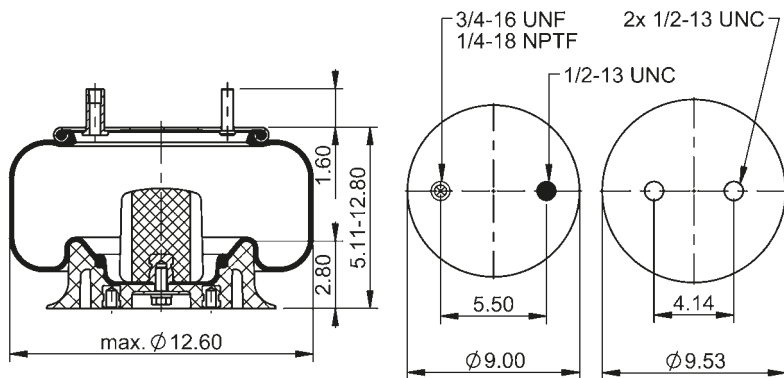

64436



**lb** 13.7 lb **No.** 9308625

**Cross-reference | Cruce de Referencia**

Firestone	W01-358-9308
Goodyear	1R12-560

**Manufacturer | Fabricante**

Reyco	17360-01
Ridewell	1003589308C
SAF Holland	90557089

1/4-18 NPTF: max. 22 lb-ft  
1/2-13 UNC: max. 35 lb-ft  
3/4-16 UNF: max. 50 lb-ft



### 9 10-10 P 399

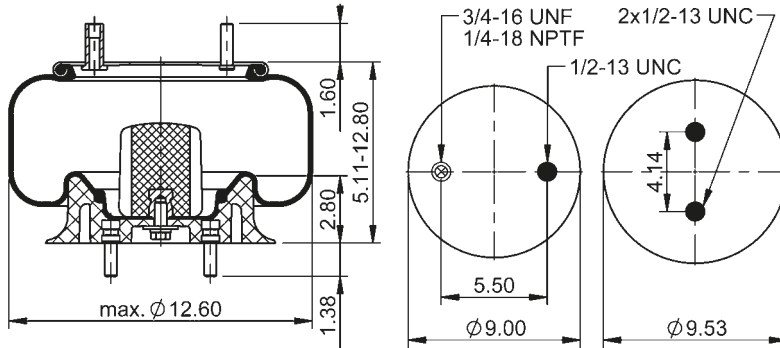

64437



**lb** 11.9 lb **No.** 9308624

**Cross-reference | Cruce de Referencia**

Firestone W01-358-9029  
Goodyear 1R12-559

**Manufacturer | Fabricante**

Ridewell 1003589029C

1/4-18 NPTF: max. 22 lb-ft

1/2-13 UNC: max. 35 lb-ft

3/4-16 UNF: max. 50 lb-ft

### 9 10-10 P 400

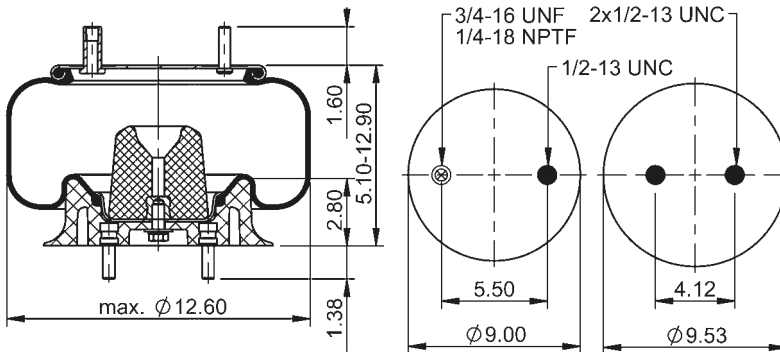

64438



**lb** 11.9 lb **No.** 9308624

**Cross-reference | Cruce de Referencia**

Firestone W01-358-8986  
Goodyear 1R12-558

**Manufacturer | Fabricante**

Ridewell 1003588986C

1/4-18 NPTF: max. 22 lb-ft

1/2-13 UNC: max. 35 lb-ft

3/4-16 UNF: max. 50 lb-ft

### 9 10-10 P 471

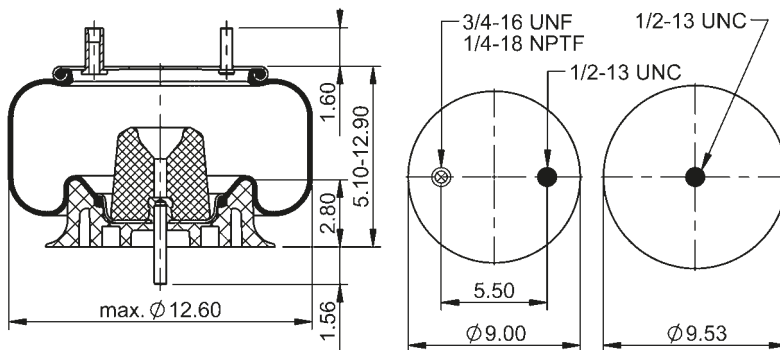

64439



**lb** 11.6 lb **No.** 9308127

**Cross-reference | Cruce de Referencia**

Firestone W01-358-9307  
Goodyear 1R12-435

**Manufacturer | Fabricante**

Reyco 17360-01

SAF Holland 90557129

1/4-18 NPTF: max. 22 lb-ft

1/2-13 UNC: max. 35 lb-ft

3/4-16 UNF: max. 50 lb-ft

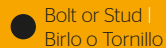

Bolt or Stud | Birlo o Tornillo



Hole | Tuerca Ciega



Combination Stud | Combinación de Entrada de Aire y Birlo



Air Inlet | Entrada de Aire



Stud and Nut | Birlo y Tuerca

### 9 10-10 P 473

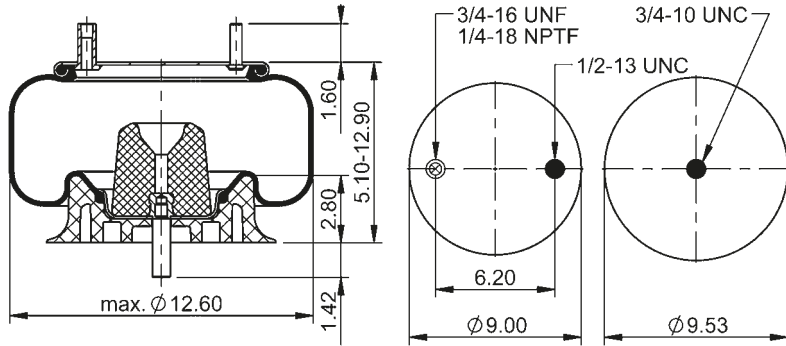

64440



**lb** 13.7 lb **No.** 9308623

**Cross-reference | Cruce de Referencia**  
Firestone W01-358-8963

**Manufacturer | Fabricante**  
Ridewell 1003588963C

**1/4-18 NPTF:** max. 22 lb-ft  
**1/2-13 UNC:** max. 35 lb-ft  
**3/4-10 UNC:** max. 50 lb-ft

### 9 10-10 P 480

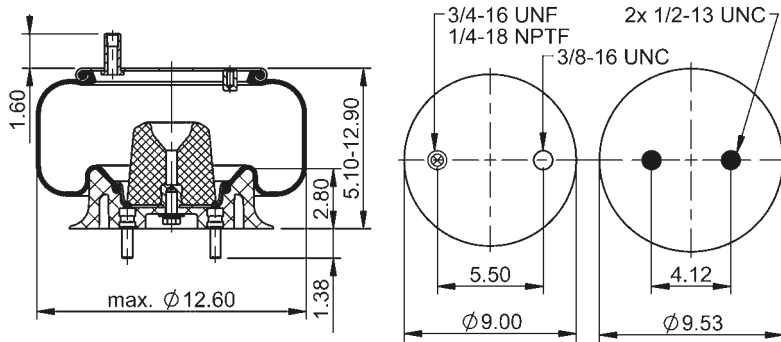

64441



**lb** 11.8 lb **No.** 9308624

**Cross-reference | Cruce de Referencia**  
Firestone W01-358-8964  
Goodyear 1R12-556

**Manufacturer | Fabricante**  
Reyco 21598-01

**1/4-18 NPTF:** max. 22 lb-ft  
**1/2-13 UNC:** max. 35 lb-ft  
**3/4-16 UNF:** max. 50 lb-ft

### 9 10-10 P 481

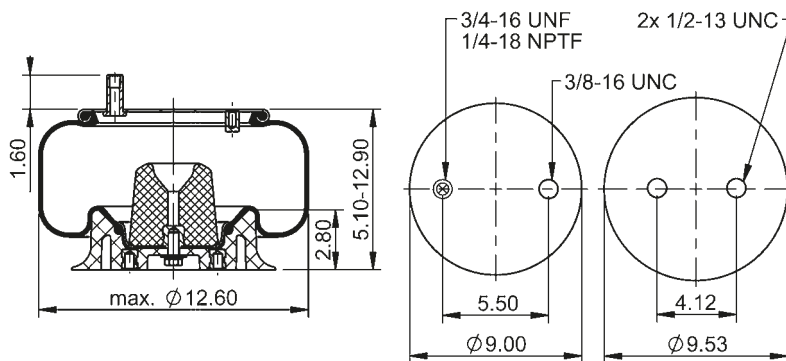

64442



**lb** 13.7 lb **No.** 9308625

**Cross-reference | Cruce de Referencia**  
Firestone W01-358-9333

**Manufacturer | Fabricante**  
Reyco 20437-01

**1/4-18 NPTF:** max. 22 lb-ft  
**1/2-13 UNC:** max. 35 lb-ft  
**3/4-16 UNF:** max. 50 lb-ft

### 9 10-10 P 482

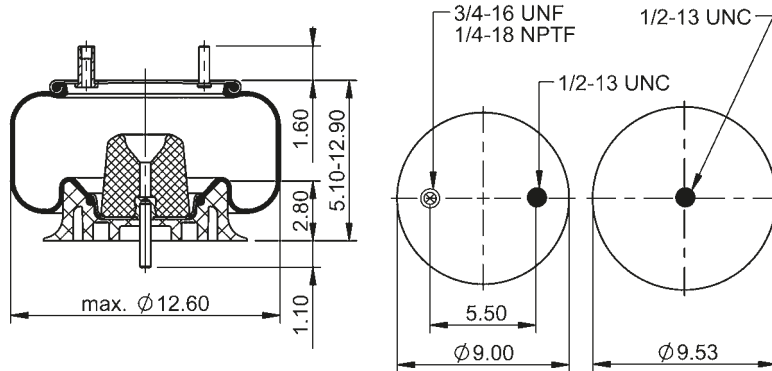

64443



**lb** 11.6 lb **No.** 9308127

**Cross-reference | Cruce de Referencia**

Firestone W01-358-9334  
Goodyear 1R12-435

**Manufacturer | Fabricante**

Ridewell 1003589334C

1/4-18 NPTF: max. 22 lb-ft  
1/2-13 UNC: max. 35 lb-ft  
3/4-16 UNF: max. 50 lb-ft

### 9 10-10 P 503

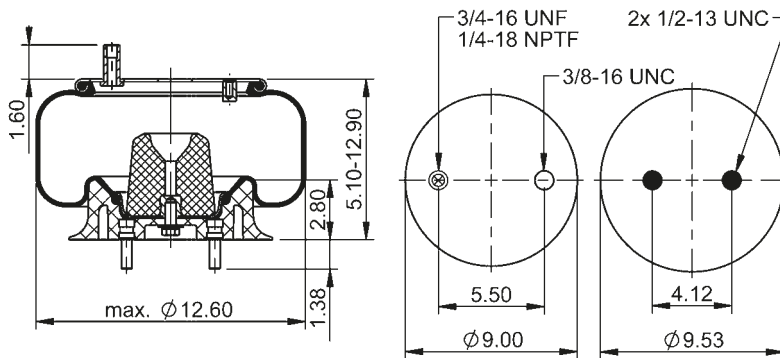

64444



**lb** 11.8 lb **No.** 9308624

**Cross-reference | Cruce de Referencia**

Firestone W01-358-8976  
Goodyear 1R12-557

**Manufacturer | Fabricante**

Reyco 21055-01

1/4-18 NPTF: max. 22 lb-ft  
1/2-13 UNC: max. 35 lb-ft  
3/4-16 UNF: max. 50 lb-ft

### 9 10-10 P 542

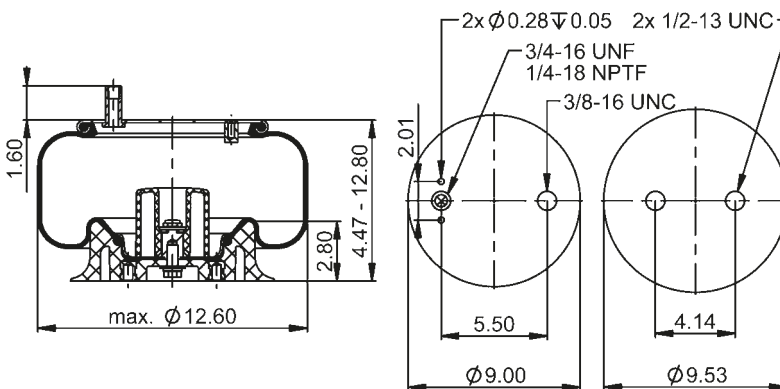

64658



**lb** 13.7 lb **No.** 9308625

**Cross-reference | Cruce de Referencia**

Firestone W01-358-8961  
Goodyear 1R12-555

**Manufacturer | Fabricante**

Reyco 23377-01

1/4-18 NPTF: max. 22 lb-ft  
1/2-13 UNC: max. 35 lb-ft  
3/4-16 UNF: max. 50 lb-ft

### 9 10-10 P 717

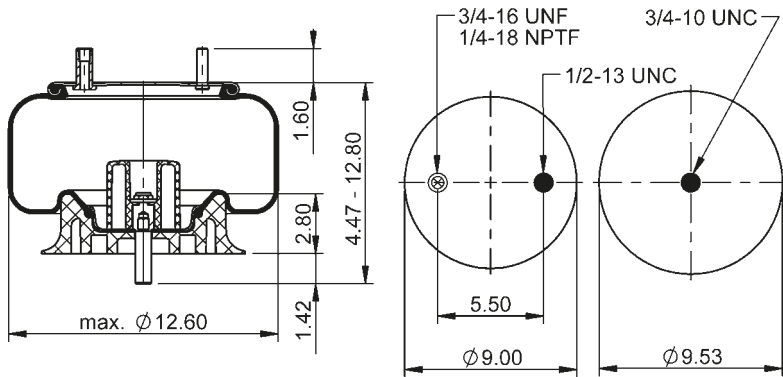

64643

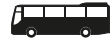

**lb** 9.9 lb **No.** 9308623

**Cross-reference | Cruce de Referencia**  
Firestone W01-358-9534

**Manufacturer | Fabricante**  
Orion 80231503  
SAF Holland 90557303  
90557325

1/4-18 NPTF: max. 22 lb-ft  
1/2-13 UNC: max. 35 lb-ft  
3/4-10 UNC: max. 50 lb-ft

### 9 10-10.5 P 122 (BK)

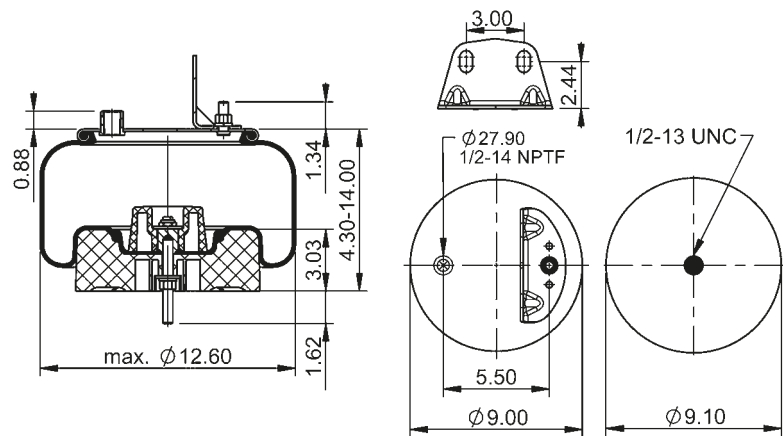

78172



**lb** 12.1 lb **No.** 9314523

**Manufacturer | Fabricante**  
SAF Holland 90557413

1/2-13 UNC: max. 35 lb-ft  
1/2-14 NPTF: max. 22 lb-ft

### 9 10-10.5 P 883

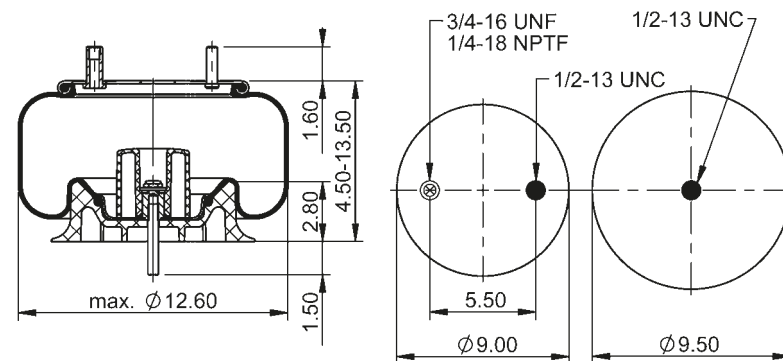

67490



**lb** 10.1 lb **No.** 9308127

**Cross-reference | Cruce de Referencia**  
Firestone W01-358-9307

**Manufacturer | Fabricante**  
SAF Holland 90557129

1/4-18 NPTF: max. 22 lb-ft  
1/2-13 UNC: max. 35 lb-ft  
3/4-16 UNF: max. 50 lb-ft

### 9 10-12 P 022

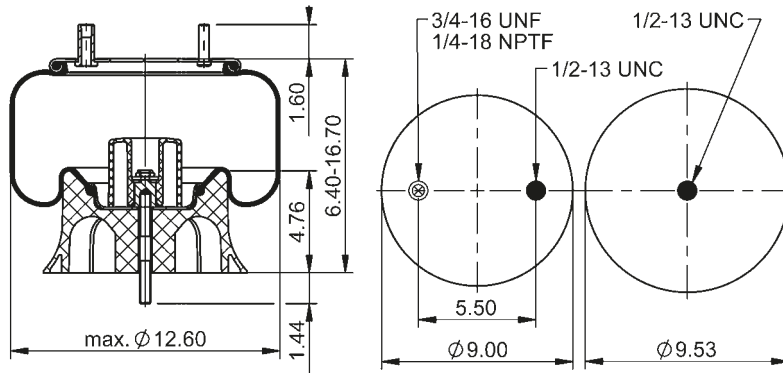

78334



**lb** 11.9 lb **No.** 9308128

**Manufacturer | Fabricante**  
SAF Holland 90557379

**1/4-18 NPTF:** max. 22 lb-ft  
**1/2-13 UNC:** max. 35 lb-ft  
**3/4-16 UNF:** max. 50 lb-ft

### 9 10-12 P 024

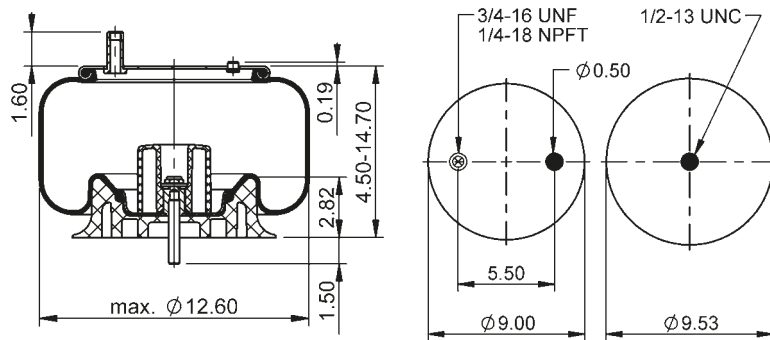

68009



**lb** 10.5 lb **No.** 9308127

**Cross-reference | Cruce de Referencia**  
Firestone W01-358-8197  
Goodyear 1R12-562

**Manufacturer | Fabricante**  
SAF Holland 90557230

**1/4-18 NPTF:** max. 22 lb-ft  
**1/2-13 UNC:** max. 35 lb-ft  
**3/4-16 UNF:** max. 50 lb-ft

### 9 10-12 A 104

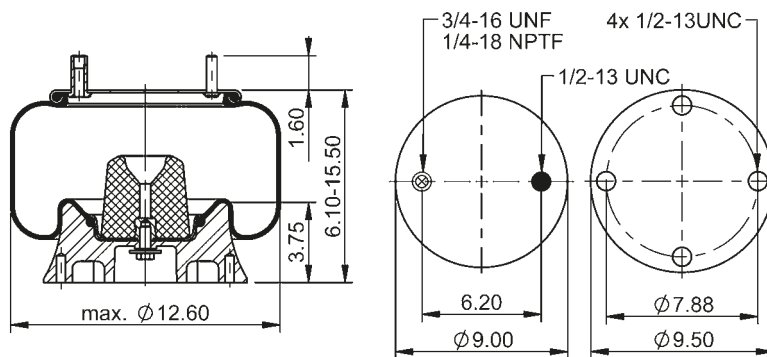

68638



**lb** 15.9 lb **No.** 9309183

**Cross-reference | Cruce de Referencia**  
Goodyear 1R12-422

**Manufacturer | Fabricante**  
Novabus N21361

**1/4-18 NPTF:** max. 22 lb-ft  
**1/2-13 UNC:** max. 35 lb-ft  
**3/4-16 UNF:** max. 50 lb-ft

### 9 10-12 A 118

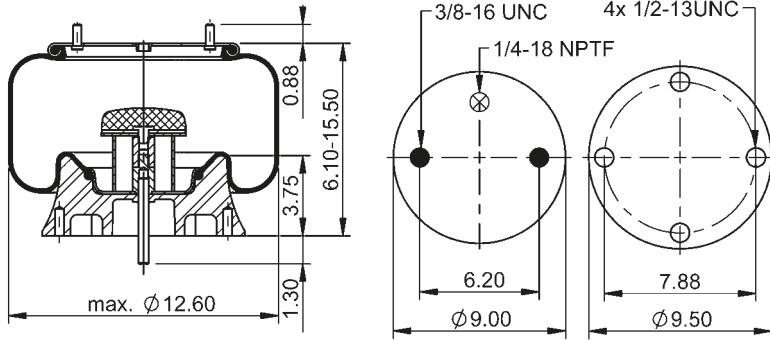

68660



**lb** 16.5 lb **No.** 9309183

**Manufacturer | Fabricante**

Raydan 211-00M-036

- 1/4-18 NPTF: max. 22 lb-ft
- 3/8-16 UNC: max. 20 lb-ft
- 1/2-13 UNC: max. 35 lb-ft

### 9 10-12 P 190

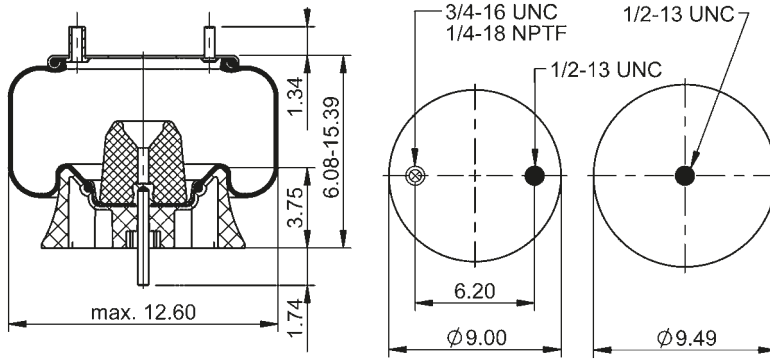

69495



**lb** 12.2 lb **No.** 9311939

**Cross-reference | Cruce de Referencia**

Firestone W01-W35-8937

**Manufacturer | Fabricante**

New Flyer 204429

- 1/4-18 NPTF: max. 22 lb-ft
- 1/2-13 UNC: max. 35 lb-ft
- 3/4-16 UNF: max. 50 lb-ft

### 9 10-12 P 319

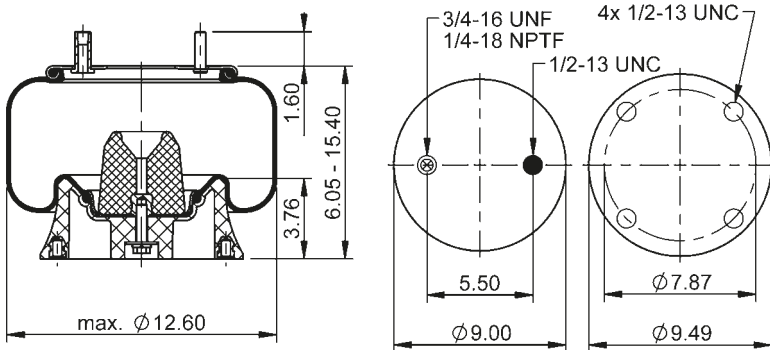

64445



**lb** 12.4 lb **No.** 9312070

**Cross-reference | Cruce de Referencia**

Firestone W01-358-9105  
Goodyear 1R12-132 (45° Piston align)  
1R12-152

**Manufacturer | Fabricante**

Meritor 200154  
Bluebird 90557038  
Flxible 6-336-205  
Hendrickson S-1245/36514-3  
SAF Holland 57009105  
Sauer P50-705  
Scania 412418  
Watson & Chalin AS-0015  
and more

- 1/4-18 NPTF: max. 22 lb-ft
- 1/2-13 UNC: max. 35 lb-ft
- 3/4-16 UNF: max. 50 lb-ft

### 9 10-12 A 327

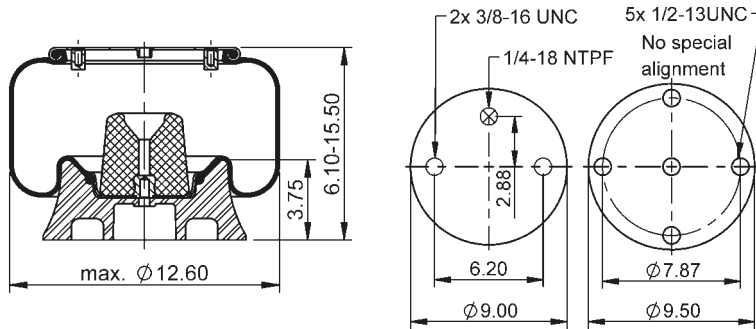

64446



**lb** 15.7 lb **No.** 9309183

**Cross-reference | Cruce de Referencia**

Firestone	W01-358-9053
Goodyear	1R12-309

**Manufacturer | Fabricante**

Hendrickson	S-13158
SAF Holland	57009053
Fruehauf	UCE-1304-2
Ridewell	1003589053C
Watson & Chalin	AS-0095
Loadguard	SC2457
EZ Ride	8030192
Fab Tek	10828
and more	

1/4-18 NPTF: max. 22 lb-ft  
 3/8-16 UNC: max. 20 lb-ft

### 9 10-12 P 329

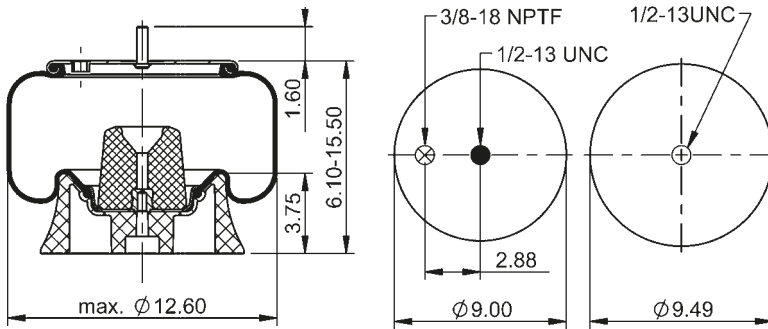

64447



**lb** 11.9 lb **No.** 9311939

**Cross-reference | Cruce de Referencia**

Firestone	W01-358-9078
Goodyear	1R12-355

**Manufacturer | Fabricante**

Fruehauf	UCB-9668-1
	MFR-022355

3/8-18 NPTF: max. 22 lb-ft  
 1/2-13 UNC: max. 35 lb-ft

### 9 10-12 A 341

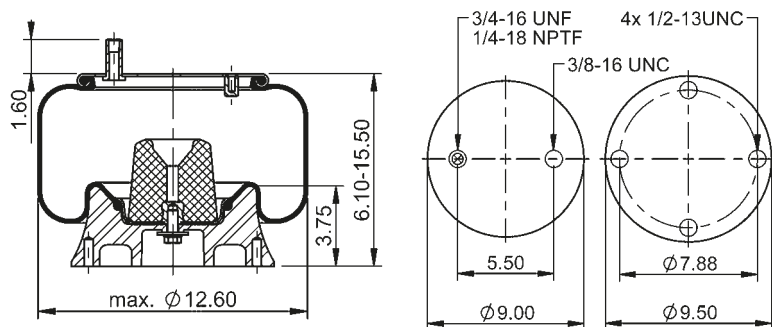

64448



**lb** 15.8 lb **No.** 9309183

**Cross-reference | Cruce de Referencia**

Firestone	W01-358-9113
Goodyear	1R12-132 (0° Piston align)

1/4-18 NPTF: max. 22 lb-ft  
 3/8-16 UNC: max. 20 lb-ft  
 3/4-16 UNF: max. 50 lb-ft

### 9 10-12 A 342

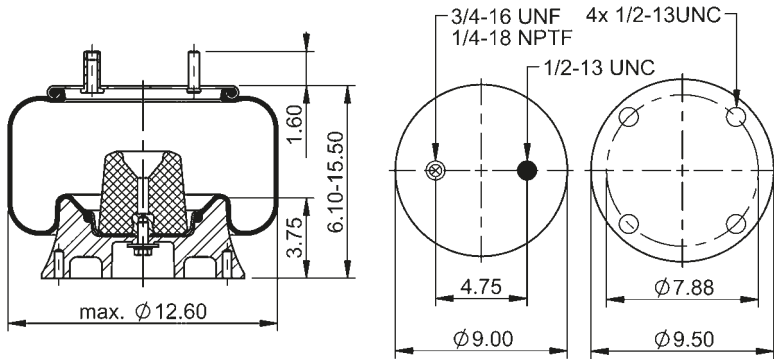

64449



**lb** 15.9 lb **No.** 9309183

**Cross-reference | Cruce de Referencia**  
 Firestone W01-358-9118

**Manufacturer | Fabricante**  
 Ridewell 1003589118C

- 1/4-18 NPTF: max. 22 lb-ft
- 1/2-13 UNC: max. 35 lb-ft
- 3/4-16 UNF: max. 50 lb-ft

### 9 10-12 P 343

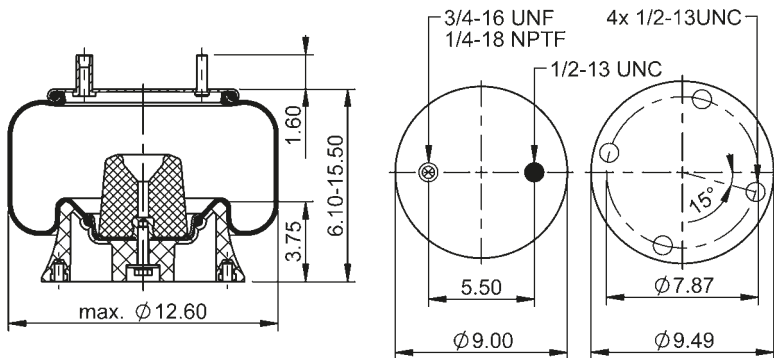

64450



**lb** 12.4 lb **No.** 9312070

**Cross-reference | Cruce de Referencia**  
 Firestone W01-358-9302  
 Goodyear 1R12-165  
 1R12-132 (15° Piston align)

**Manufacturer | Fabricante**  
 Hendrickson 36514-3  
 B-12514-003  
 SAF Holland 57009302  
 Taurus AS302-9302

- 1/4-18 NPTF: max. 22 lb-ft
- 1/2-13 UNC: max. 35 lb-ft
- 3/4-16 UNF: max. 50 lb-ft

### 9 10-12 P 395

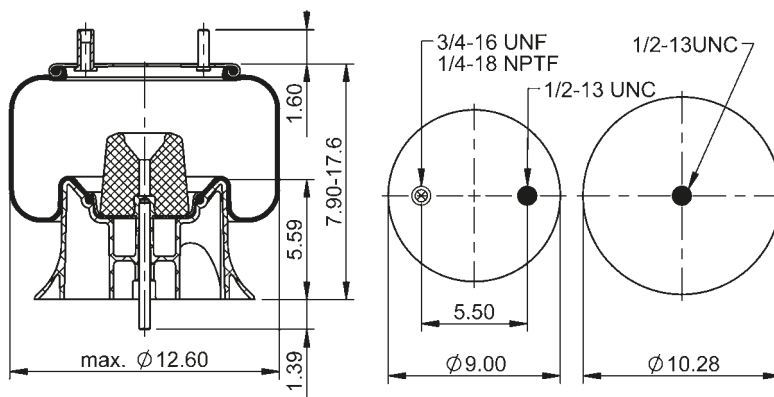

64451



**lb** 13.4 lb **No.** 9314552

**Cross-reference | Cruce de Referencia**  
 Firestone W01-358-9325  
 Goodyear 1R12-505

**Manufacturer | Fabricante**  
 Gillig 8717289  
 Mahowk 82-17289-000  
 SAF Holland 90557149

- 1/4-18 NPTF: max. 22 lb-ft
- 1/2-13 UNC: max. 35 lb-ft
- 3/4-16 UNF: max. 50 lb-ft



### 9 10-12 P 396

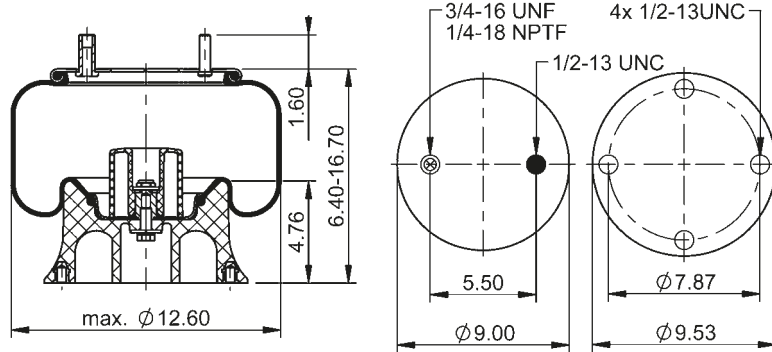

64452



**lb** 11.6 lb **No.** 9308301

**Cross-reference | Cruce de Referencia**  
 Firestone W01-358-8930

**Manufacturer | Fabricante**  
 Ridewell 1003588930C

1/4-18 NPTF: max. 22 lb-ft  
 1/2-13 UNC: max. 35 lb-ft  
 3/4-16 UNF: max. 50 lb-ft

### 9 10-12 A 427

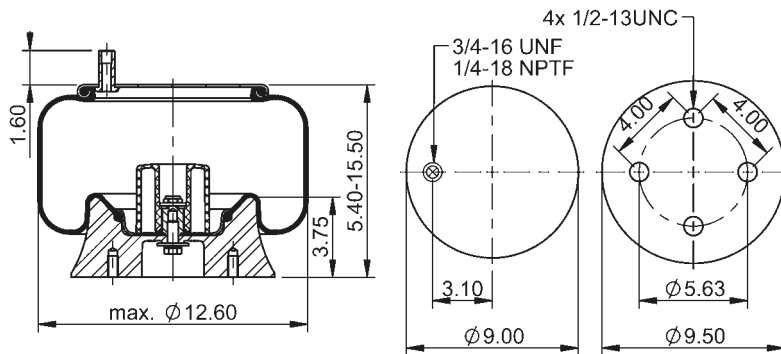

64395



**lb** 14.6 lb **No.** 9309183

**Cross-reference | Cruce de Referencia**  
 Firestone W01-358-9640  
 Goodyear 1R12-367

**Manufacturer | Fabricante**  
 Hendrickson S-20223  
 Loadguard SC2758

1/4-18 NPTF: max. 22 lb-ft  
 1/2-13 UNC: max. 35 lb-ft  
 3/4-16 UNF: max. 50 lb-ft

### 9 10-12 A 463

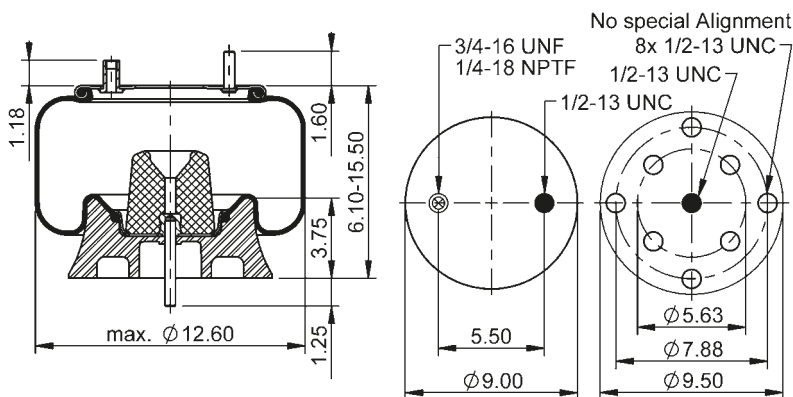

64454



**lb** 16.0 lb **No.** 9309183

**Manufacturer | Fabricante**  
 Raydan 211-00-030  
 225-8Z1-508  
 AL460  
 AL520

1/4-18 NPTF: max. 22 lb-ft  
 1/2-13 UNC: max. 35 lb-ft  
 3/4-16 UNF: max. 50 lb-ft

### 9 10-12 P 463

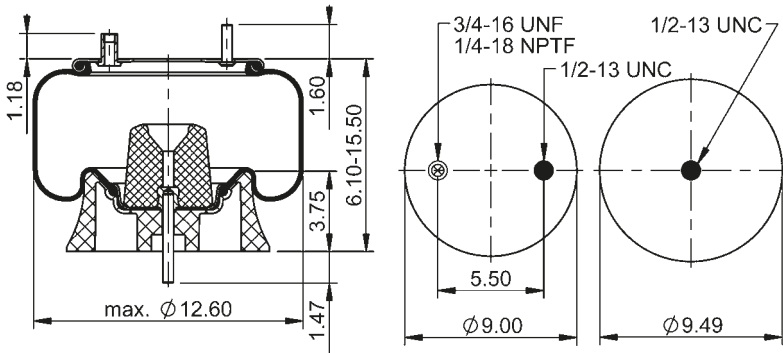

67577



**lb** 12.1 lb **No.** 9311939

**Manufacturer | Fabricante**

Raydan 211-00-030  
225-8Z1-508  
AL460  
AL520

- 1/4-18 NPTF: max. 22 lb-ft
- 1/2-13 UNC: max. 35 lb-ft
- 3/4-16 UNF: max. 50 lb-ft

### 9 10-12 P 483

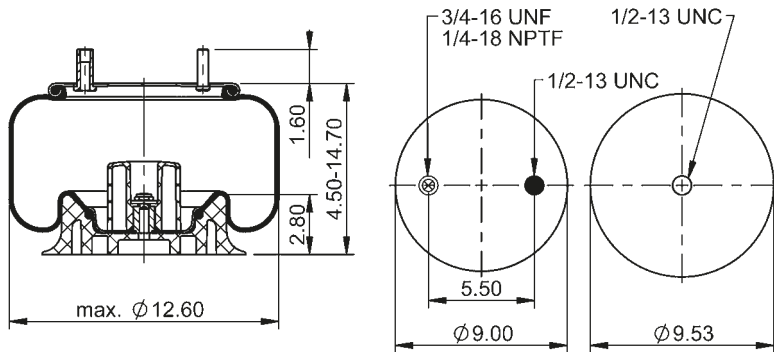

64455



**lb** 10.2 lb **No.** 9308127

**Cross-reference | Cruce de Referencia**

Firestone W01-358-8201

**Manufacturer | Fabricante**

Ridewell 1003588201C

- 1/4-18 NPTF: max. 22 lb-ft
- 1/2-13 UNC: max. 35 lb-ft
- 3/4-16 UNF: max. 50 lb-ft

### 9 10-12 P 484

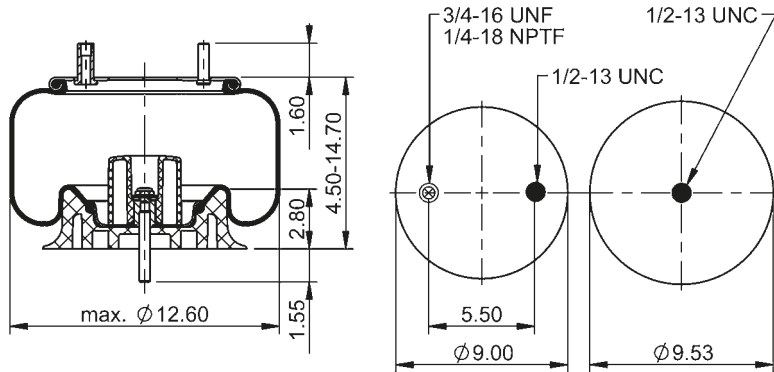

64456



**lb** 10.4 lb **No.** 9308127

**Cross-reference | Cruce de Referencia**

Firestone W01-358-8204  
Goodyear 1R12-508

**Manufacturer | Fabricante**

Binkley XB-SPN-053-37  
Newlite NS19016  
SAF Holland 90557223  
90557173  
XDSPN05360

- 1/4-18 NPTF: max. 22 lb-ft
- 1/2-13 UNC: max. 35 lb-ft
- 3/4-16 UNF: max. 50 lb-ft

### 9 10-12 P 485

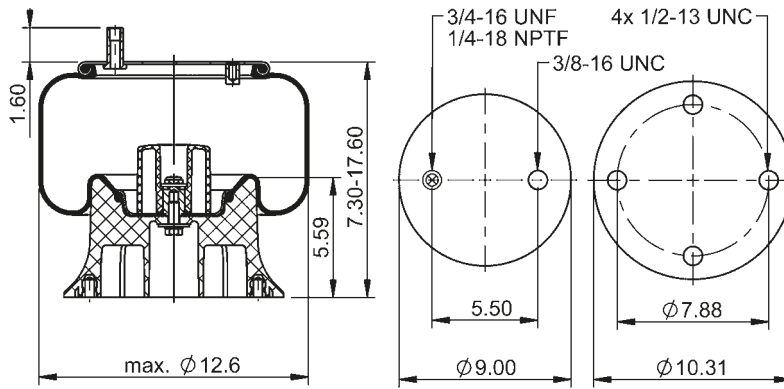

64457



**lb** 12.7 lb **No.** 9308133

**Cross-reference | Cruce de Referencia**  
Firestone W01-358-8932

**Manufacturer | Fabricante**  
Reyco 22241-01

1/4-18 NPTF: max. 22 lb-ft  
3/8-16 UNC: max. 20 lb-ft  
3/4-16 UNF: max. 50 lb-ft

### 9 10-12 P 487 (BK)

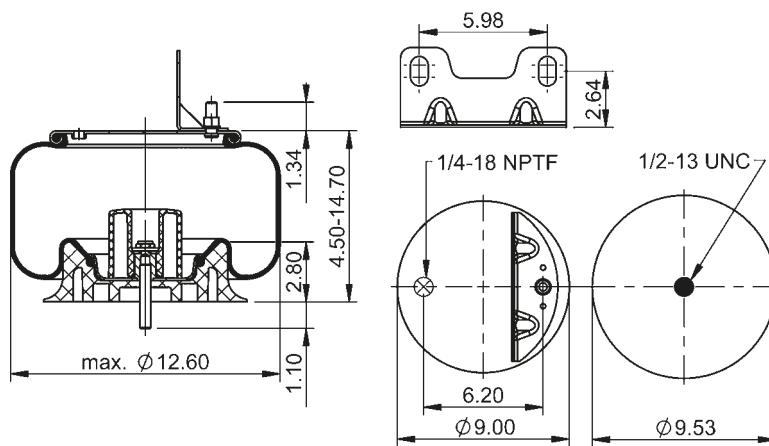

69645



**lb** 10.1 lb **No.** 9308127

**Cross-reference | Cruce de Referencia**  
Firestone W01-358-9339

**Manufacturer | Fabricante**  
Chevrolet 15963147  
15963148  
Hendrickson 56808-2  
57140LH  
57150RH

1/4-18 NPTF: max. 22 lb-ft  
1/2-13 UNC: max. 35 lb-ft

### 9 10-12 P 488

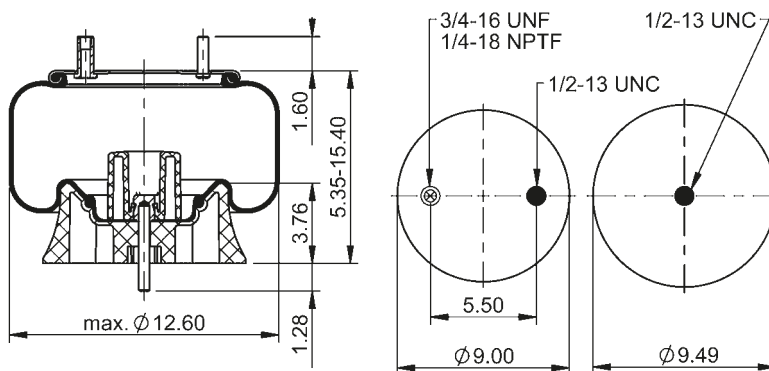

64459



**lb** 10.7 lb **No.** 9311939

**Cross-reference | Cruce de Referencia**  
Firestone W01-358-9366  
Goodyear 1R12-487

**Manufacturer | Fabricante**  
SAF Holland 90557160  
90557210  
90557225  
Watson & Chalin AS-0054

1/4-18 NPTF: max. 22 lb-ft  
1/2-13 UNC: max. 35 lb-ft  
3/4-16 UNF: max. 50 lb-ft

### 9 10-12 P 495

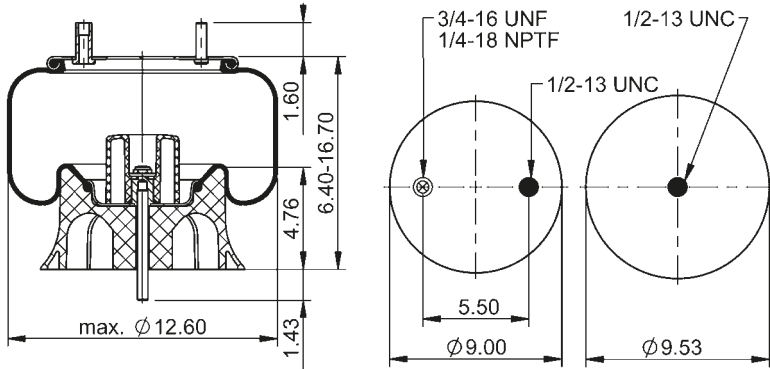

64460



**lb** 11.6 lb **No.** 9308128

**Cross-reference | Cruce de Referencia**

Firestone W01-358-9365  
Goodyear 1R12-571

**Manufacturer | Fabricante**

SAF Holland 90557159

- 1/4-18 NPTF: max. 22 lb-ft
- 1/2-13 UNC: max. 35 lb-ft
- 3/4-16 UNF: max. 50 lb-ft

### 9 10-12 P 543

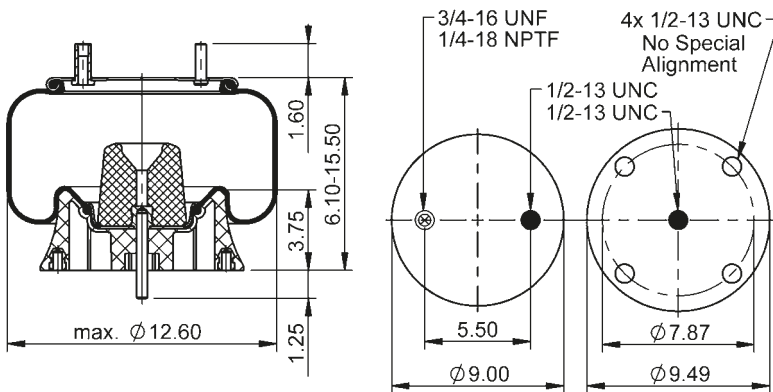

64462



**lb** 12.4 lb **No.** 9312070

**Cross-reference | Cruce de Referencia**

Firestone W01-358-8203  
Goodyear 1R12-1094

**Manufacturer | Fabricante**

Meritor 2258C1459  
SAF Holland 90557210

- 1/4-18 NPTF: max. 22 lb-ft
- 1/2-13 UNC: max. 35 lb-ft
- 3/4-16 UNF: max. 50 lb-ft

### 9 10-12 P 544

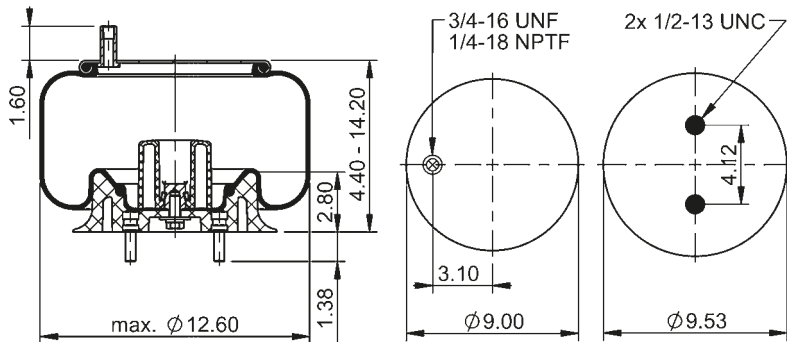

64463



**lb** 10.5 lb **No.** 9308624

**Cross-reference | Cruce de Referencia**

Firestone W01-358-8934  
Goodyear 1R12-563

**Manufacturer | Fabricante**

Hendrickson S-20228

- 1/4-18 NPTF: max. 22 lb-ft
- 1/2-13 UNC: max. 35 lb-ft
- 3/4-16 UNF: max. 50 lb-ft

### 9 10-12 A 707

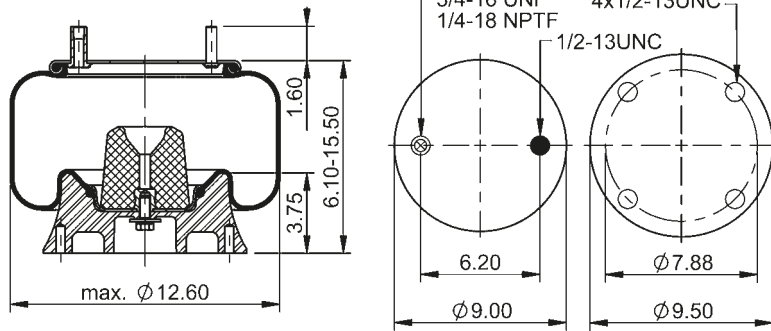

64633



**lb** 12.3 lb **No.** 9309183

**Cross-reference | Cruce de Referencia**  
 Firestone W01-358-9127  
 Goodyear 1R12-512

**Manufacturer | Fabricante**  
 New Flyer 9594

1/4-18 NPTF: max. 22 lb-ft  
 1/2-13 UNC: max. 35 lb-ft  
 3/4-16 UNF: max. 50 lb-ft

### 9 10-12 P 707

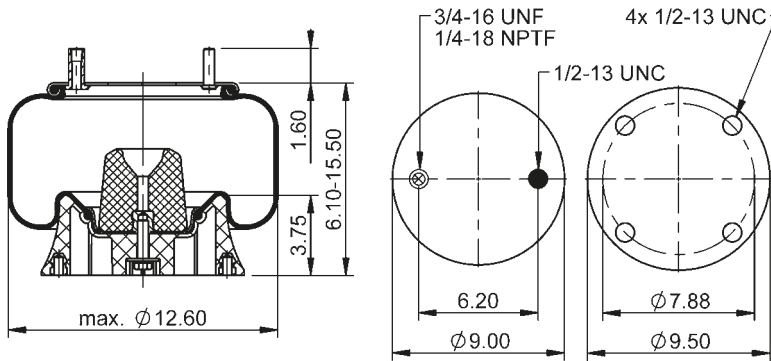

69541



**lb** 12.3 lb **No.** 9312070

**Cross-reference | Cruce de Referencia**  
 Firestone W01-358-9127  
 Goodyear 1R12-512

**Manufacturer | Fabricante**  
 New Flyer 9594

1/4-18 NPTF: max. 22 lb-ft  
 1/2-13 UNC: max. 35 lb-ft  
 3/4-16 UNF: max. 50 lb-ft

### 9 10-12 P 720

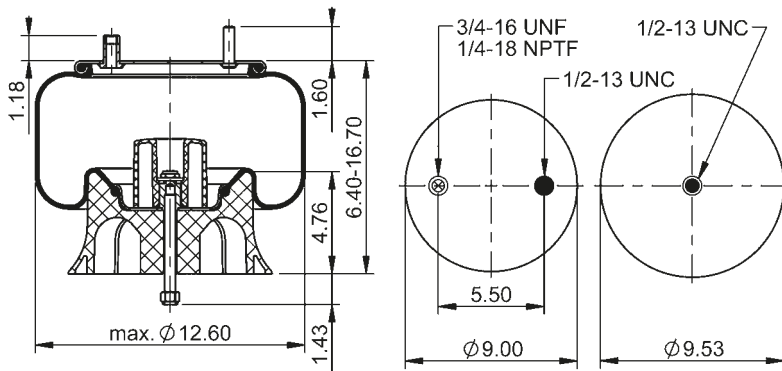

64646



**lb** 11.7 lb **No.** 9308128

**Cross-reference | Cruce de Referencia**  
 Firestone W01-358-7667

**Manufacturer | Fabricante**  
 SAF Holland 90557256

1/4-18 NPTF: max. 22 lb-ft  
 1/2-13 UNC: max. 35 lb-ft  
 3/4-16 UNF: max. 50 lb-ft

### 9 10-12 P 839

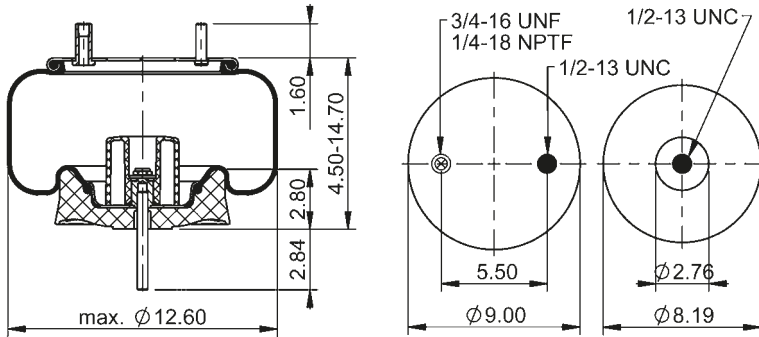

### 66117



**lb** 10.7 lb **No.** 9311561

**Cross-reference | Cruce de Referencia**  
Firestone W01-358-8882

**Manufacturer | Fabricante**  
SAF Holland 90557306

- 1/4-18 NPTF: max. 22 lb-ft
- 1/2-13 UNC: max. 35 lb-ft
- 3/4-16 UNF: max. 50 lb-ft

### 9 10-12 A 848

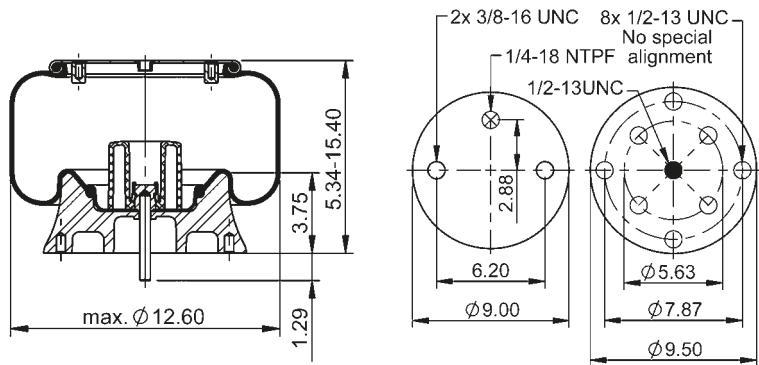

### 66029



**lb** 14.7 lb **No.** 9309183

**Manufacturer | Fabricante**  
Raydan 211-00M-034 R01

- 1/4-18 NPTF: max. 22 lb-ft
- 3/8-16 UNC: max. 20 lb-ft
- 1/2-13 UNC: max. 35 lb-ft

### 9 10-12 P 932

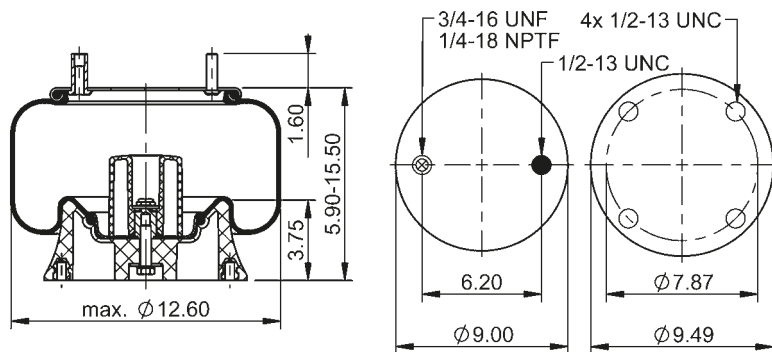

### 67696



**lb** 11.0 lb **No.** 9312070

**Cross-reference | Cruce de Referencia**  
Firestone W01-358-8646

- 1/4-18 NPTF: max. 22 lb-ft
- 1/2-13 UNC: max. 35 lb-ft
- 3/4-16 UNF: max. 50 lb-ft

### 9 10-12 P 1145

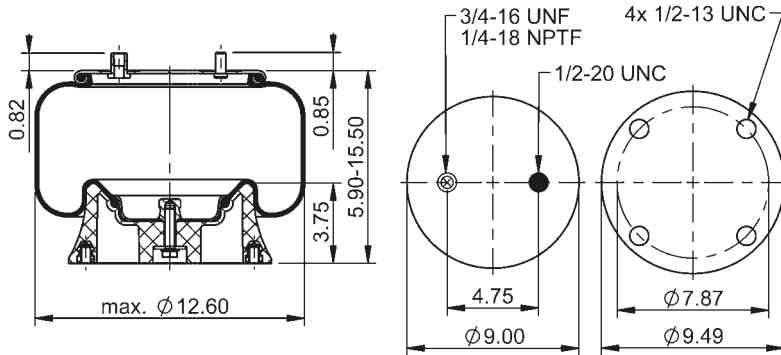

74790



**lb** 10.1 lb **No.** 9312070

**Cross-reference | Cruce de Referencia**  
 Firestone W01-358-9100  
 Goodyear 1R12-076

**Manufacturer | Fabricante**  
 New Flyer 5973876

1/4-18 NPTF: max. 22 lbft  
 1/2-13 UNC: max. 35 lbft  
 3/4-16 UNF: max. 50 lbft

### 9 10-12 A 1284

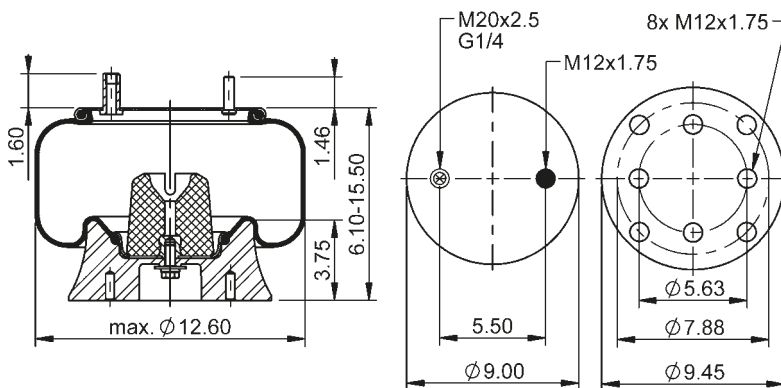

77203



**lb** 16.1 lb **No.** 9316248

**Cross-reference | Cruce de Referencia**  
 Firestone W01-358-8931

**Manufacturer | Fabricante**  
 John Deere AN205362

G1/4: max. 22 lbft  
 M12x1.75: max. 35 lbft  
 M20x2.5: max. 35 lbft

### 9 10-12 P 1291

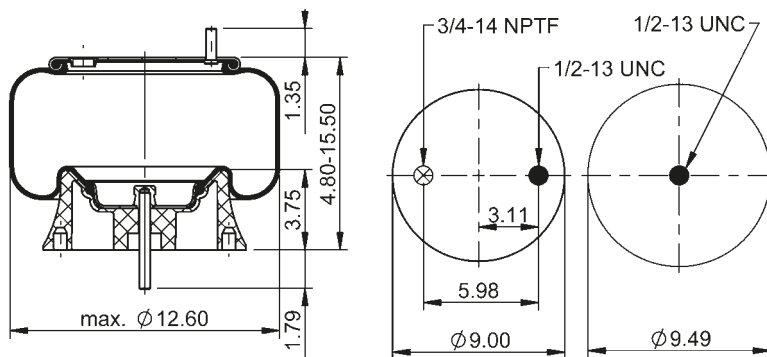

77433



**lb** 9.9 lb **No.** 9311939

**Cross-reference | Cruce de Referencia**  
 Firestone W01-358-8207

**Manufacturer | Fabricante**  
 Freightliner 16-16019-000

1/2-13 UNC: max. 35 lbft  
 3/4-14 NPTF: max. 22 lbft

### 9 10JS-13 S 1104

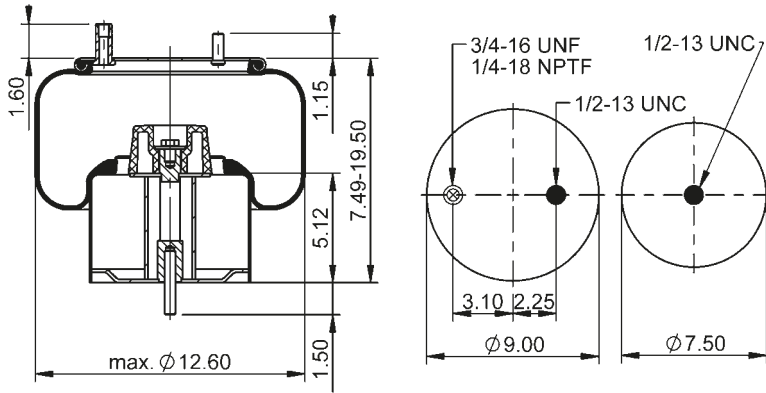

78242



**lb** 17.9 lb **No.** 9317375

**Manufacturer | Fabricante**  
Hendrickson 13675

**1/4-18 NPTF:** max. 22 lb-ft  
**1/2-13 UNC:** max. 35 lb-ft  
**3/4-16 UNF:** max. 50 lb-ft

### 9 10S-13 P 264

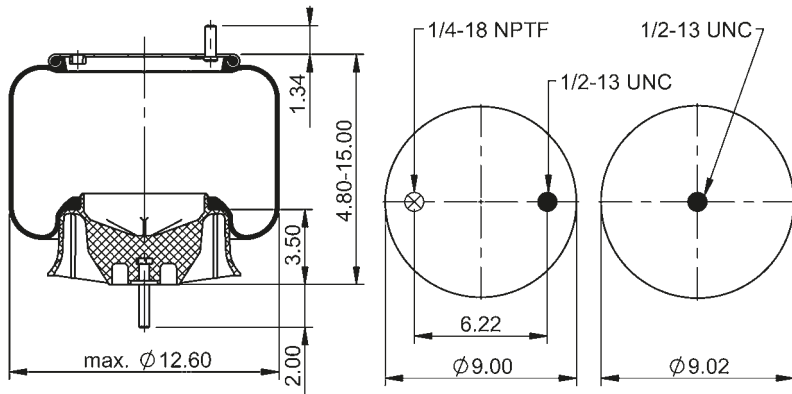

70023



**lb** 9.3 lb **No.** 9312831

**Manufacturer | Fabricante**  
Freightliner A16-18333-000  
A16-18333-001

**1/4-18 NPTF:** max. 22 lb-ft  
**1/2-13 UNC:** max. 35 lb-ft

### 9 10-13.5 P 232

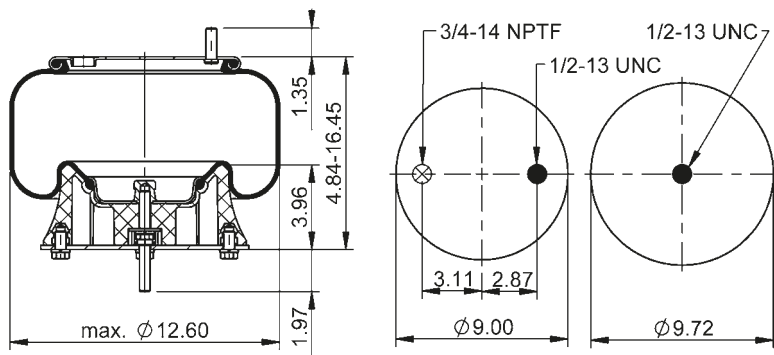

69800



**lb** 11.0 lb **No.** 9312070

**Cross-reference | Cruce de Referencia**  
Firestone W01-358-9774

**Manufacturer | Fabricante**  
Freightliner 16-15762-000

**1/2-13 UNC:** max. 35 lb-ft  
**3/4-14 NPTF:** max. 22 lb-ft



### 9 10-13.5 S 433

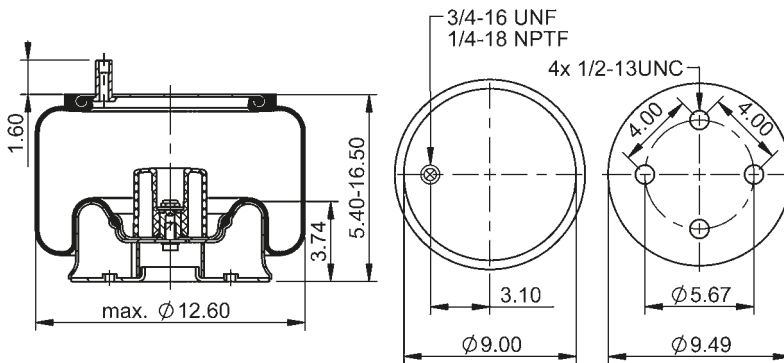

64287



**lb** 18.8 lb **No.** 9309758

**Cross-reference | Cruce de Referencia**

Firestone W01-358-9270  
Goodyear 1R13-119

**Manufacturer | Fabricante**

Brake & Wheel M3542  
Hendrickson S-20010  
Ridewell 1003589270C  
Volvo 85101147  
Watson & Chalin AS-0084

1/4-18 NPTF: max. 22 lb-ft  
1/2-13 UNC: max. 35 lb-ft  
3/4-16 UNF: max. 50 lb-ft

### 9 10-13.5 S 734

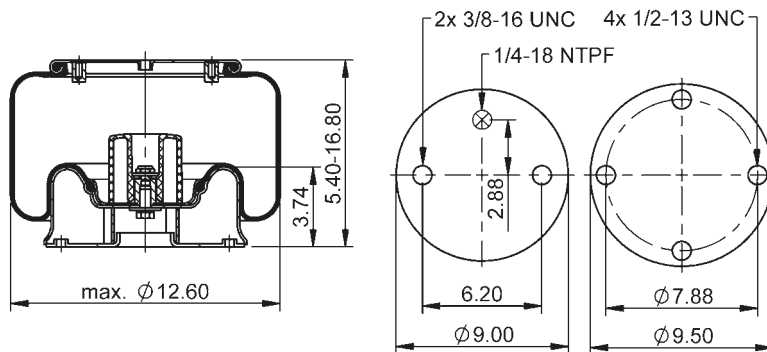

64667



**lb** 18.5 lb **No.** 9311827

**Manufacturer | Fabricante**

Granning 704691-01

1/4-18 NPTF: max. 22 lb-ft  
3/8-16 UNC: max. 20 lb-ft  
1/2-13 UNC: max. 35 lb-ft

### 9 10-13.5 P 874

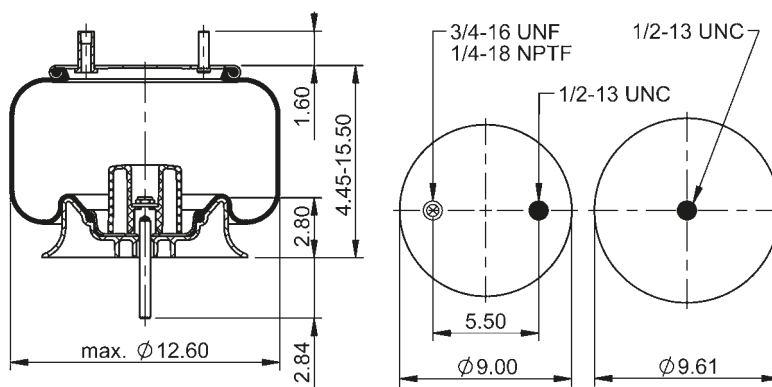

68151



**lb** 11.0 lb **No.** 9314157

**Cross-reference | Cruce de Referencia**

Firestone W01-358-9807  
Goodyear 1R12-1047

**Manufacturer | Fabricante**

SAF Holland 50857000  
90557372

1/4-18 NPTF: max. 22 lb-ft  
1/2-13 UNC: max. 35 lb-ft  
3/4-16 UNF: max. 50 lb-ft

### 9 10-13.5 S 881

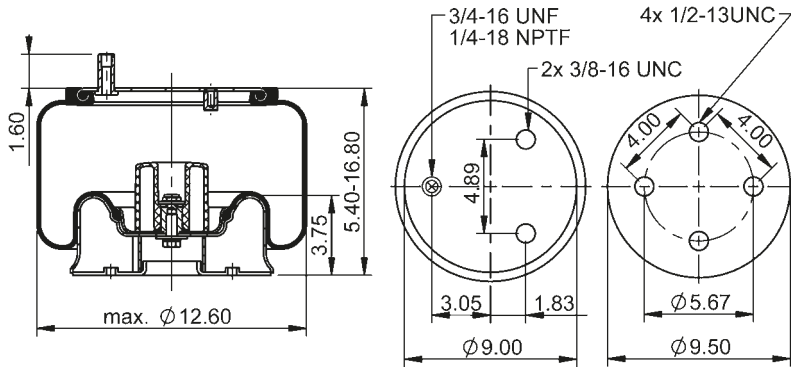

66447



**lb** 19.0 lb **No.** 9309758

**Cross-reference | Cruce de Referencia**

Firestone	W01-358-9579
Goodyear	W01-358-8800 1R13-239

**Manufacturer | Fabricante**

Hendrickson S-21208

- 1/4-18 NPTF: max. 22 lb-ft
- 3/8-16 UNC: max. 20 lb-ft
- 1/2-13 UNC: max. 35 lb-ft

### 9 10-13.5 P 978

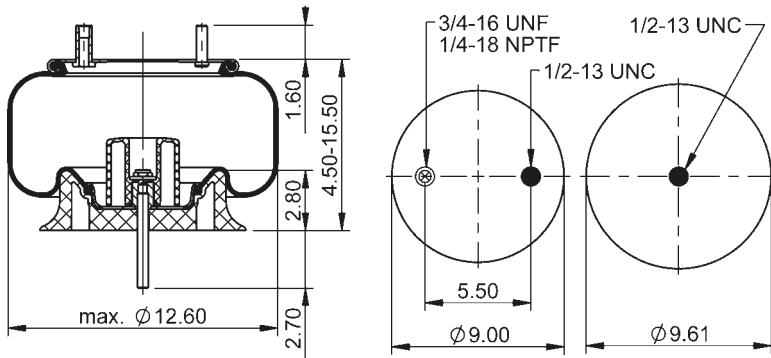

68152



**lb** 11.2 lb **No.** 9314157

**Manufacturer | Fabricante**

SAF Holland 90557375

- 1/4-18 NPTF: max. 22 lb-ft
- 1/2-13 UNC: max. 35 lb-ft
- 3/4-16 UNF: max. 50 lb-ft

### 9 10-13.5 P 1394

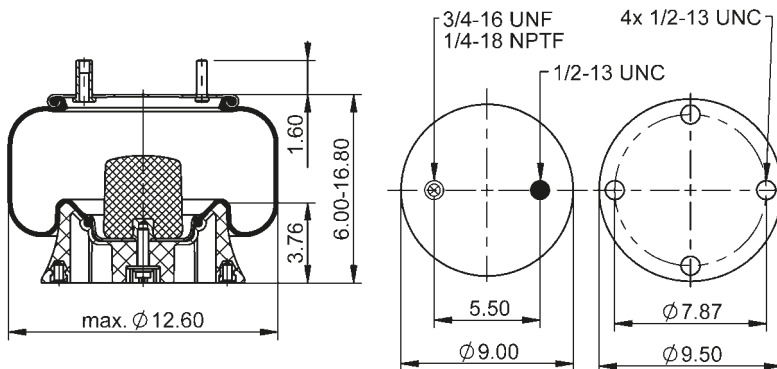

78638



**lb** 12.3 lb **No.** 9312070

**Cross-reference | Cruce de Referencia**

Firestone	W01-358-9303
Goodyear	1R12-614

- 1/4-18 NPTF: max. 22 lb-ft
- 1/2-13 UNC: max. 35 lb-ft
- 3/4-16 UNC: max. 50 lb-ft

### 9 10C-13.5 P 1082

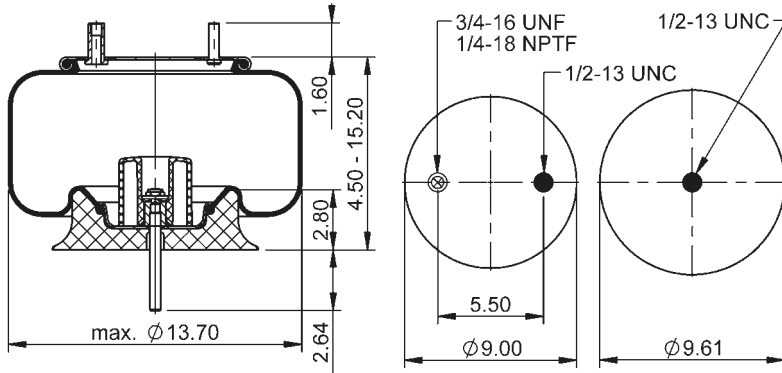

78225



**lb** 10.4 lb **No.** 9314157

**Manufacturer | Fabricante**  
SAF Holland 90557428

1/4-18 NPTF: max. 22 lbft  
1/2-13 UNC: max. 35 lbft  
3/4-16 UNF: max. 50 lbft

### 9 10-14 A 103

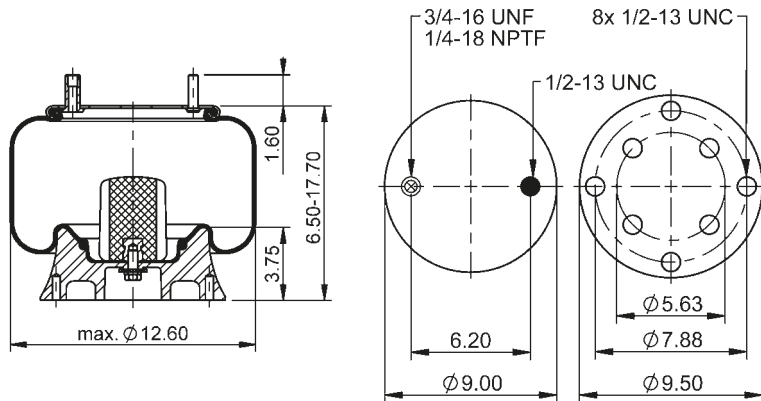

68620



**lb** 16.0 lb **No.** 9309183

**Cross-reference | Cruce de Referencia**  
Firestone W01-358-9469  
Goodyear 1R11-223

1/4-18 NPTF: max. 22 lbft  
1/2-13 UNC: max. 35 lbft  
3/4-16 UNF: max. 50 lbft

### 9 10-14 P 188

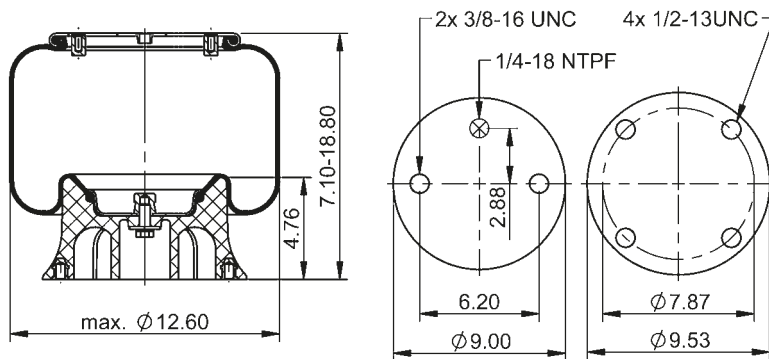

69493



**lb** 11.2 lb **No.** 9308301

**Cross-reference | Cruce de Referencia**  
Firestone W01-358-9959

**Manufacturer | Fabricante**  
New Flyer 65

1/4-18 NPTF: max. 22 lbft  
3/8-16 UNC: max. 20 lbft  
1/2-13 UNC: max. 35 lbft

### 9 10-14 P 220

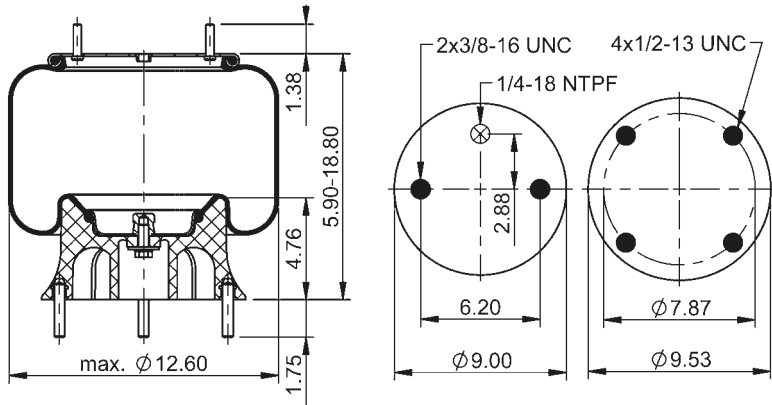

69774



**lb** 11.0 lb **No.** 9308301

**Manufacturer | Fabricante**  
New Flyer 65

- 1/4-18 NPTF: max. 22 lb-ft
- 3/8-16 UNC: max. 20 lb-ft
- 1/2-13 UNC: max. 35 lb-ft

### 9 10-14 P 297

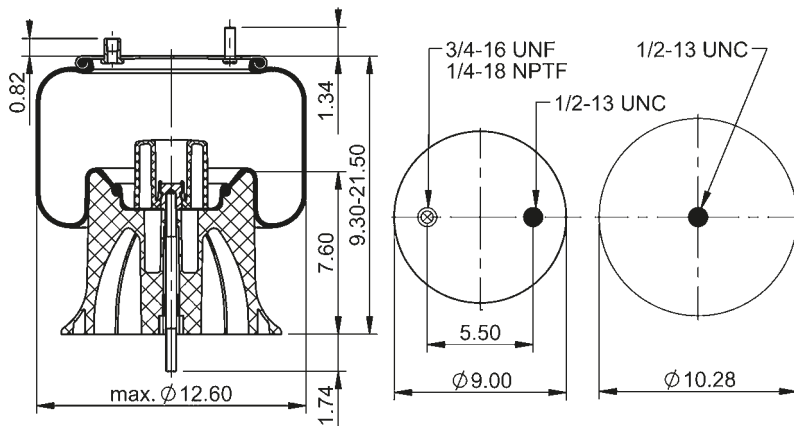

78176



**lb** 14.1 lb **No.** 9306248

**Manufacturer | Fabricante**  
SAF Holland 90557418

- 1/4-18 NPTF: max. 22 lb-ft
- 1/2-13 UNC: max. 35 lb-ft
- 3/4-16 UNF: max. 50 lb-ft

### 9 10-14 A 312

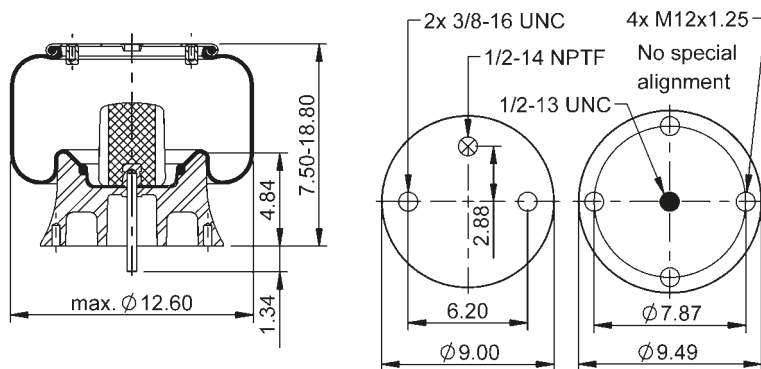

75626



**lb** 16.3 lb **No.** 9305281

**Cross-reference | Cruce de Referencia**  
Goodyear 1R12-669

**Manufacturer | Fabricante**

- Hendrickson S-13031
- Peterbilt 03-01649
- 03-02038
- 03-02456
- 03-04759
- 03-06746
- 03-07112
- 03-10042

and more

- 3/8-16 UNC: max. 20 lb-ft
- 1/2-13 UNC: max. 35 lb-ft
- 1/2-14 NPTF: max. 22 lb-ft

### 9 10-14 P 312

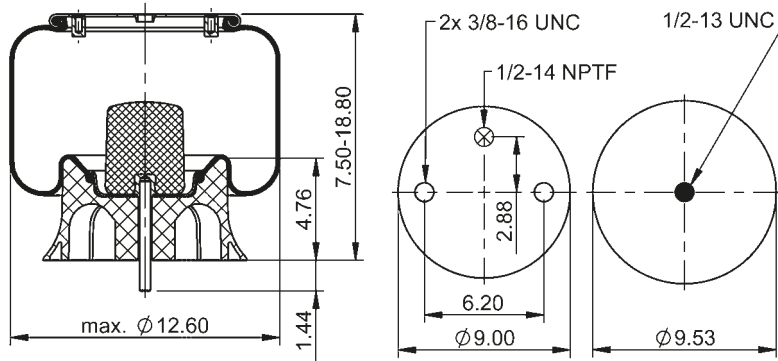

64274



**lb** 13.2 lb **No.** 9308128

**Cross-reference | Cruce de Referencia**

Firestone	W01-358-9069
Goodyear	1R12-069
	1R12-676

**Manufacturer | Fabricante**

Hendrickson	S-13031
Peterbilt	03-01649
	03-02038
	03-02456
	03-04759
	03-06746
	03-07112
	03-10042

and more

3/8-16 UNC: max. 20 lb-ft  
 1/2-13 UNC: max. 35 lb-ft  
 1/2-14 NPTF: max. 22 lb-ft

### 9 10-14 A 330

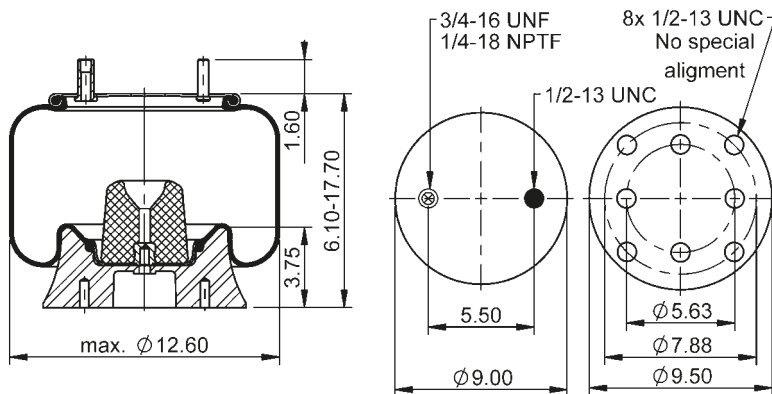

64464



**lb** 16.2 lb **No.** 9309183

**Cross-reference | Cruce de Referencia**

Firestone	W01-358-9070
Goodyear	1R12-370

**Manufacturer | Fabricante**

Gillig	5309611001
Loadguard	SC2775
R&S Truck	1090276
SAF Holland	90557038
	90557090
Silent Drive	AS-9070
Taurus	AS504-9070
Watson & Chalin	AS-0050

1/4-18 NPTF: max. 22 lb-ft  
 1/2-13 UNC: max. 35 lb-ft  
 3/4-16 UNF: max. 50 lb-ft

### 9 10-14 P 335

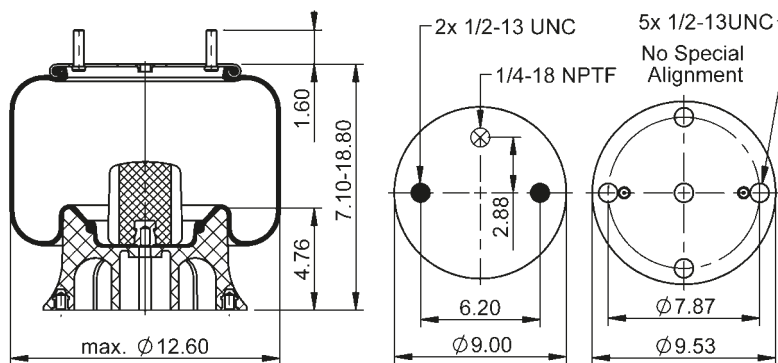

64465



**lb** 13.2 lb **No.** 9308301

**Cross-reference | Cruce de Referencia**

Firestone	W01-358-9059
-----------	--------------

**Manufacturer | Fabricante**

Hutchens	H-1913-1
Ridewell	1003589059C

1/4-18 NPTF: max. 22 lb-ft  
 1/2-13 UNC: max. 35 lb-ft

### 9 10-14 P 344

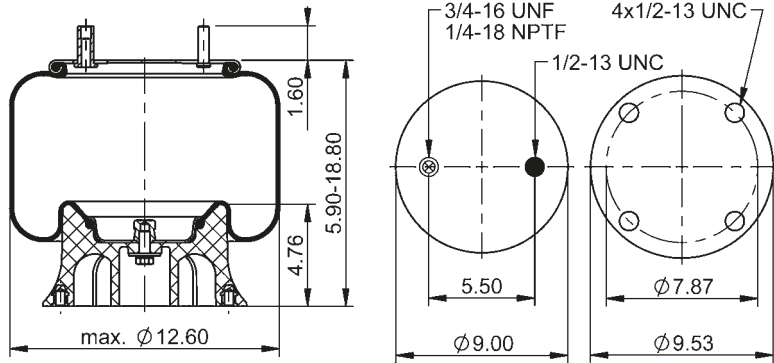

64466



**lb** 11.2 lb **No.** 9308301

**Cross-reference | Cruce de Referencia**  
Firestone W01-358-9008

**Manufacturer | Fabricante**  
Ridewell 1003589008C

1/4-18 NPTF: max. 22 lb-ft  
1/2-13 UNC: max. 35 lb-ft  
3/4-16 UNF: max. 50 lb-ft

### 9 10-14 P 345

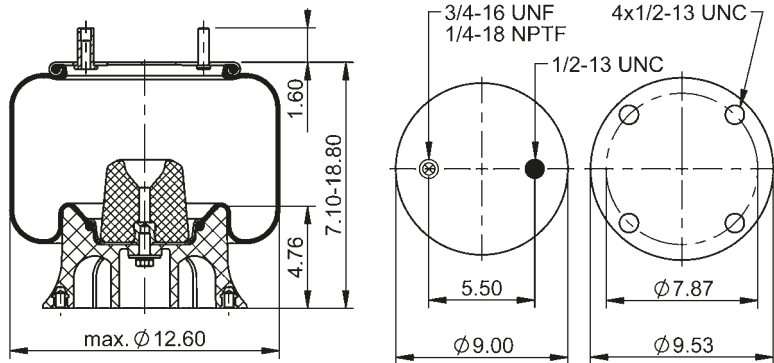

64258



**lb** 13.4 lb **No.** 9308301

**Cross-reference | Cruce de Referencia**  
Firestone W01-358-9010  
Goodyear 1R12-421  
1R12-352

**Manufacturer | Fabricante**  
Hendrickson S-2827  
S-11566  
Reyco 12928-01  
Ridewell 1003589010C  
Watson & Chalin AS-0044

1/4-18 NPTF: max. 22 lb-ft  
1/2-13 UNC: max. 35 lb-ft  
3/4-16 UNF: max. 50 lb-ft

### 9 10-14 P 346

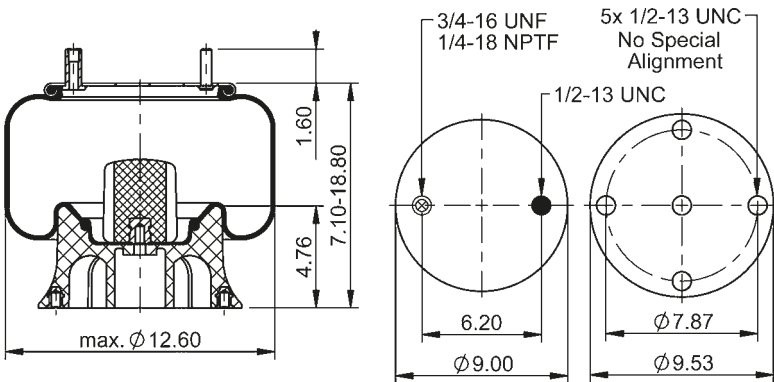

64467



**lb** 13.2 lb **No.** 9308301

**Cross-reference | Cruce de Referencia**  
Firestone W01-358-9011

**Manufacturer | Fabricante**  
Dayton 352-9011  
Hendrickson S-2307  
Watson & Chalin AS-0130

1/4-18 NPTF: max. 22 lb-ft  
1/2-13 UNC: max. 35 lb-ft  
3/4-16 UNF: max. 50 lb-ft

### 9 10-14 P 347

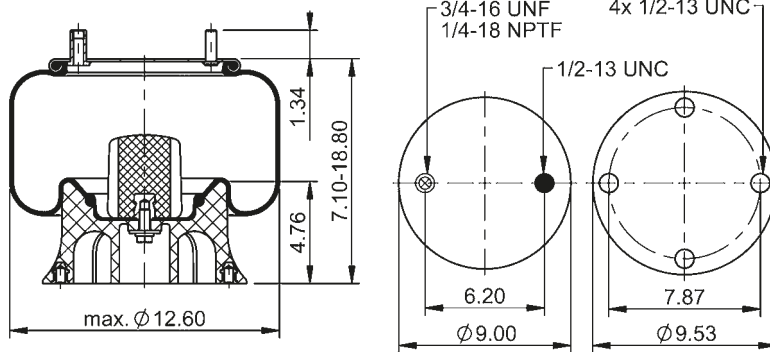

65364



**lb** 13.4 lb **No.** 9308301

**Cross-reference | Cruce de Referencia**  
Firestone W01-358-9063

**Manufacturer | Fabricante**  
Navistar/Fleetrite 359519C1

1/4-18 NPTF: max. 22 lb-ft  
1/2-13 UNC: max. 35 lb-ft  
3/4-16 UNF: max. 50 lb-ft

### 9 10-14 P 348

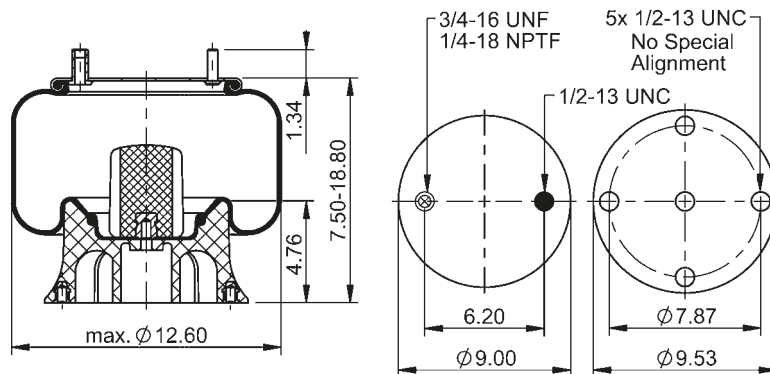

64468



**lb** 13.0 lb **No.** 9308301

**Cross-reference | Cruce de Referencia**  
Firestone W01-358-9068

**Manufacturer | Fabricante**  
Navistar/Fleetrite 350449C1

1/4-18 NPTF: max. 22 lb-ft  
1/2-13 UNC: max. 35 lb-ft  
3/4-16 UNF: max. 50 lb-ft

### 9 10-14 P 349

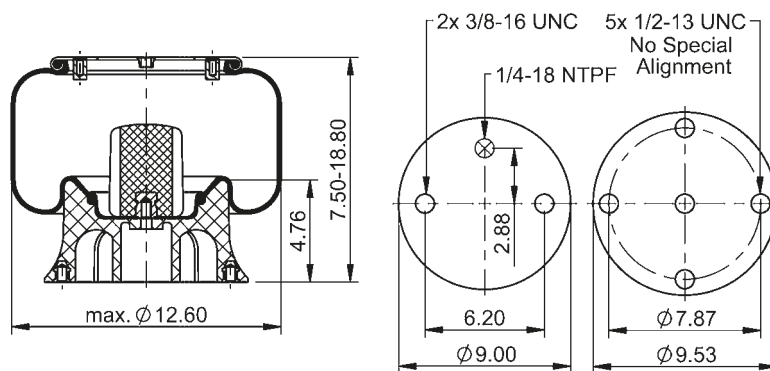

64469



**lb** 12.9 lb **No.** 9308301

**Cross-reference | Cruce de Referencia**  
Firestone W01-358-9071

**Manufacturer | Fabricante**  
Fab Tek 101357  
Ridewell 1003589071C

1/4-18 NPTF: max. 22 lb-ft  
3/8-16 UNC: max. 20 lb-ft  
1/2-13 UNC: max. 35 lb-ft

### 9 10-14 P 381

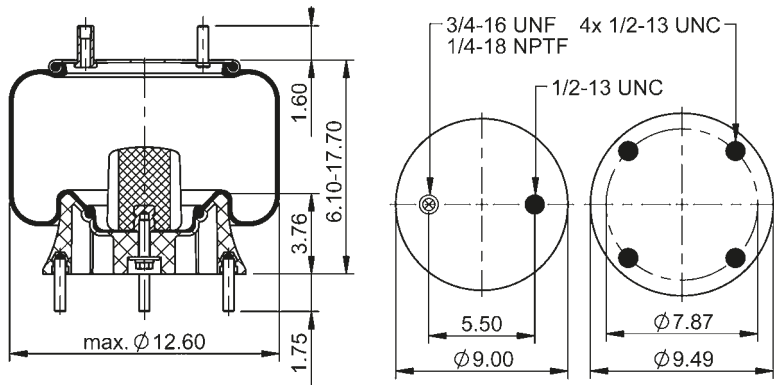

64470



**lb** 12.8 lb **No.** 9312070

**Cross-reference | Cruce de Referencia**  
Firestone W01-358-9798

**Manufacturer | Fabricante**  
Chevrolet 15630691  
SAF Holland 90557105  
90557137

1/4-18 NPTF: max. 22 lb-ft  
1/2-13 UNC: max. 35 lb-ft  
3/4-16 UNF: max. 50 lb-ft

### 9 10-14 P 437

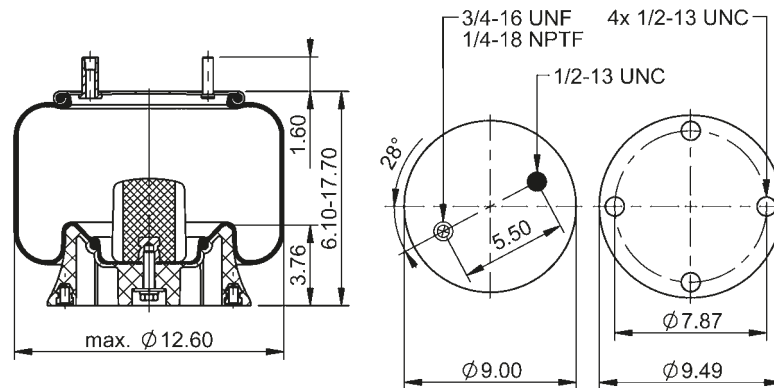

64471



**lb** 12.7 lb **No.** 9312070

**Cross-reference | Cruce de Referencia**  
Firestone W01-358-9463

**Manufacturer | Fabricante**  
SAF Holland 90557130  
90557131

1/2-13 UNC: max. 35 lb-ft  
1/2-14 NPTF: max. 22 lb-ft  
3/4-16 UNF: max. 50 lb-ft

### 9 10-14 P 450

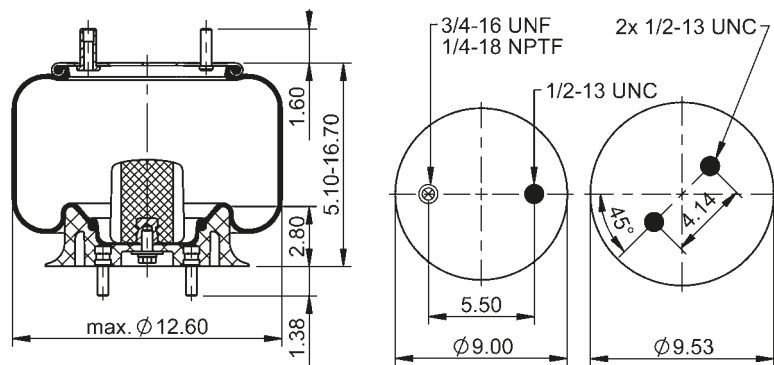

64472



**lb** 12.3 lb **No.** 9308624

**Cross-reference | Cruce de Referencia**  
Firestone W01-358-9568  
Goodyear 1R12-205

**Manufacturer | Fabricante**  
Navistar/Fleetrite 1675495C1

1/4-18 NPTF: max. 22 lb-ft  
1/2-13 UNC: max. 35 lb-ft  
3/4-16 UNF: max. 50 lb-ft



### 9 10-14 P 461

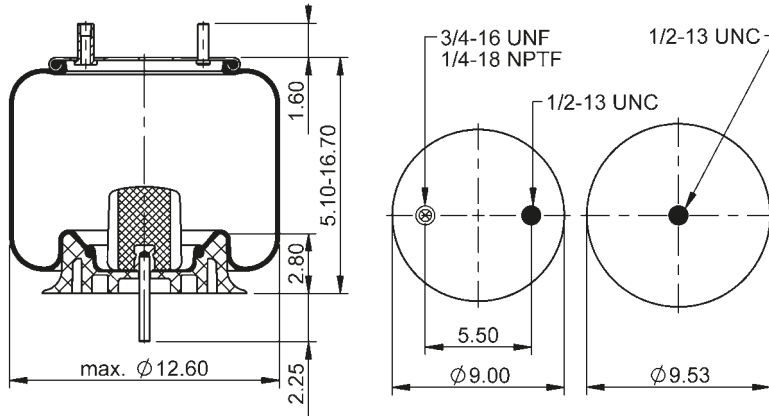

64473



**lb** 12.3 lb **No.** 9308127

**Cross-reference | Cruce de Referencia**  
 Firestone W01-358-9567  
 Goodyear 1R12-325

**Manufacturer | Fabricante**  
 Loadguard SC2769  
 Navistar/Fleetrite 2027913C1

1/4-18 NPTF: max. 22 lb-ft  
 1/2-13 UNC: max. 35 lb-ft  
 3/4-16 UNF: max. 50 lb-ft

### 9 10-14 P 462

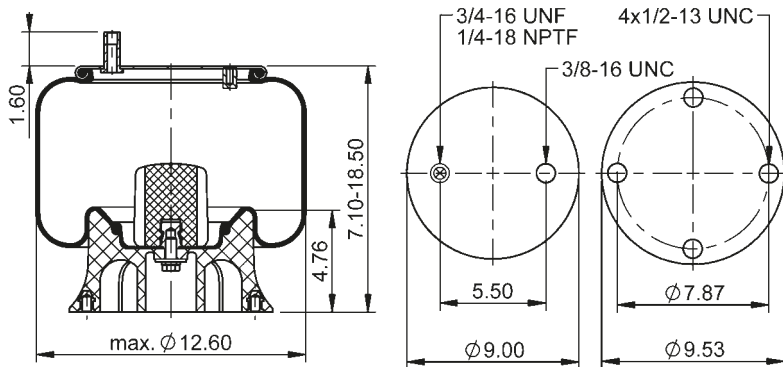

64474



**lb** 13.3 lb **No.** 9308301

**Cross-reference | Cruce de Referencia**  
 Firestone W01-358-8805  
 Goodyear 1R12-438

**Manufacturer | Fabricante**  
 Ridewell 1003588805C

1/4-18 NPTF: max. 22 lb-ft  
 1/2-13 UNC: max. 35 lb-ft  
 3/4-16 UNF: max. 50 lb-ft

### 9 10-14 P 465 (BK)

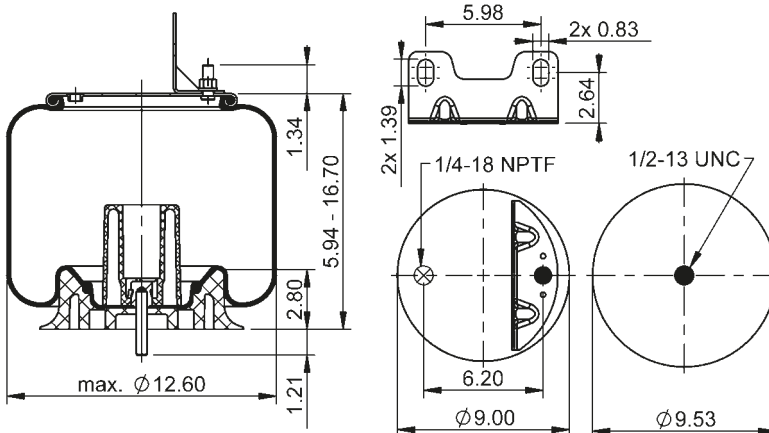

69644



**lb** 10.9 lb **No.** 9308127

**Cross-reference | Cruce de Referencia**  
 Firestone W01-358-9335  
 Goodyear 1R12-620

**Manufacturer | Fabricante**  
 Ford F3H5580AA  
 Hendrickson 56917-1  
 56917-2

1/4-18 NPTF: max. 22 lb-ft  
 1/2-13 UNC: max. 35 lb-ft

### 9 10-14 P 469

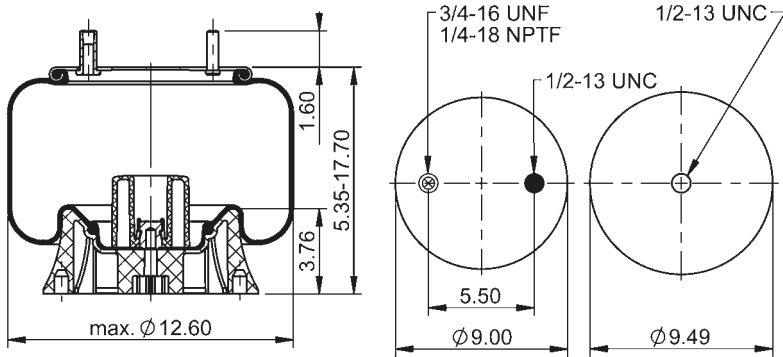

64477



**lb** 10.8 lb **No.** 9311939

**Cross-reference | Cruce de Referencia**

Firestone W01-358-8802  
Goodyear 1R12-434

**Manufacturer | Fabricante**

Ridewell 1003588802C  
SAF Holland 90557170

- 1/4-18 NPTF: max. 22 lb-ft
- 1/2-13 UNC: max. 35 lb-ft
- 3/4-16 UNF: max. 50 lb-ft

### 9 10-14 P 489

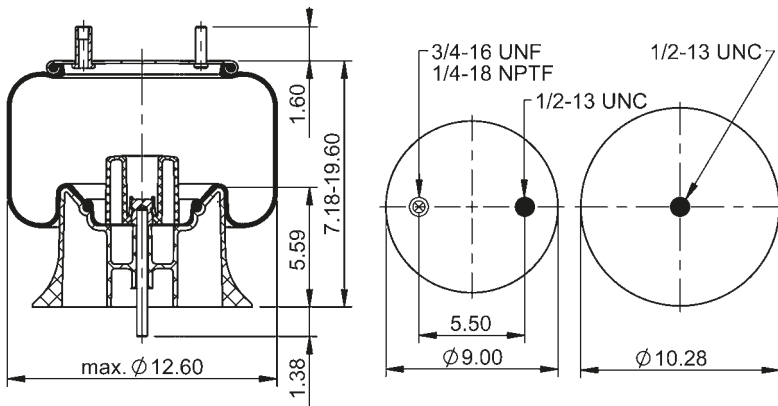

64478



**lb** 12.3 lb **No.** 9314552

**Cross-reference | Cruce de Referencia**

Firestone W01-358-8803

**Manufacturer | Fabricante**

Ridewell 1003588803C  
SAF Holland 90557194  
90557189

- 1/4-18 NPTF: max. 22 lb-ft
- 1/2-13 UNC: max. 35 lb-ft
- 3/4-16 UNF: max. 50 lb-ft

### 9 10-14 P 490

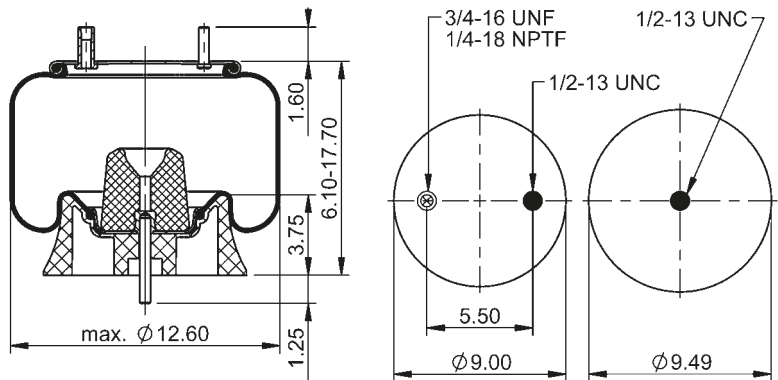

64479



**lb** 12.4 lb **No.** 9311939

**Cross-reference | Cruce de Referencia**

Firestone W01-358-9336  
Goodyear 1R12-648

**Manufacturer | Fabricante**

Watson & Chalin AS-0053

- 1/4-18 NPTF: max. 22 lb-ft
- 1/2-13 UNC: max. 35 lb-ft
- 3/4-16 UNF: max. 50 lb-ft

### 9 10-14 A 491

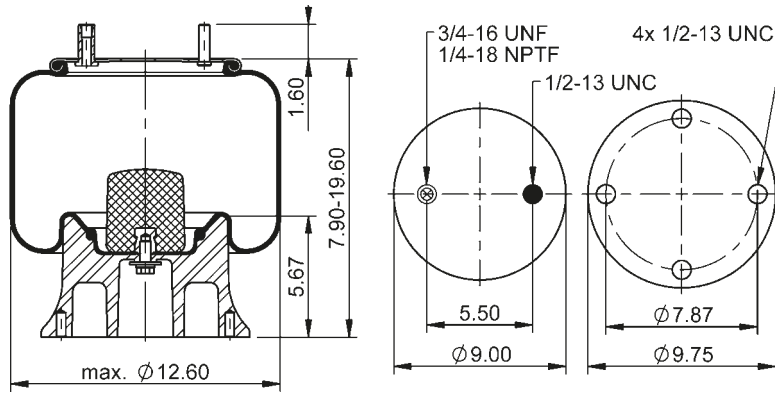

64480



**lb** 16.4 lb **No.** 9311400

**Cross-reference | Cruce de Referencia**  
Firestone W01-358-9467

**Manufacturer | Fabricante**  
Ridewell 1003589467C

1/4-18 NPTF: max. 22 lb-ft  
1/2-13 UNC: max. 35 lb-ft  
3/4-16 UNF: max. 50 lb-ft

### 9 10-14 P 492 (BK)

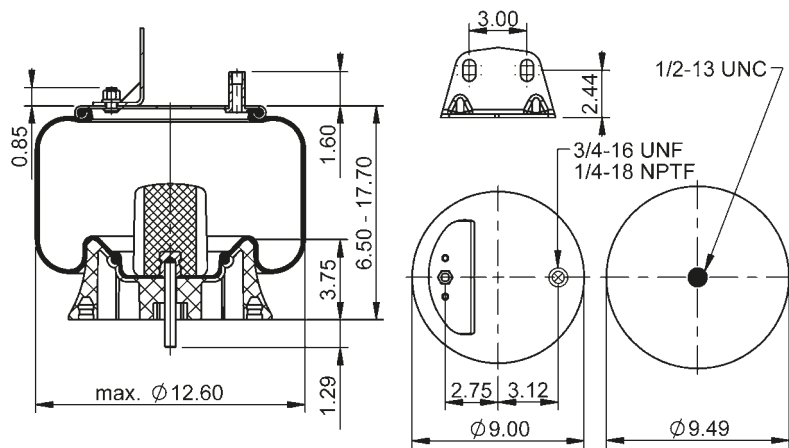

69651



**lb** 12.2 lb **No.** 9311939

**Cross-reference | Cruce de Referencia**  
Firestone W01-358-9482

**Manufacturer | Fabricante**  
SAF Holland 90557161  
90557219

1/4-18 NPTF: max. 22 lb-ft  
1/2-13 UNC: max. 35 lb-ft  
3/4-16 UNF: max. 50 lb-ft

### 9 10-14 P 493

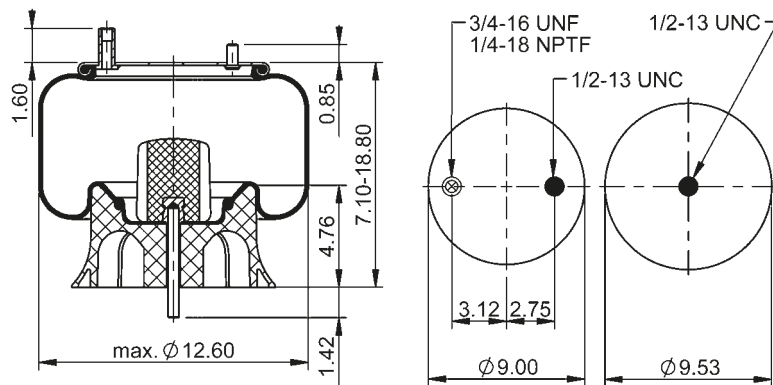

64482



**lb** 13.5 lb **No.** 9308128

**Cross-reference | Cruce de Referencia**  
Firestone W01-358-9483

**Manufacturer | Fabricante**  
SAF Holland 90557166

1/4-18 NPTF: max. 22 lb-ft  
1/2-13 UNC: max. 35 lb-ft  
3/4-16 UNF: max. 50 lb-ft

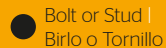

Bolt or Stud | Birlo o Tornillo



Hole | Tuerca Ciega



Combination Stud | Combinación de Entrada de Aire y Birlo



Air Inlet | Entrada de Aire



Stud and Nut | Birlo y Tuerca

### 9 10-14 P 494

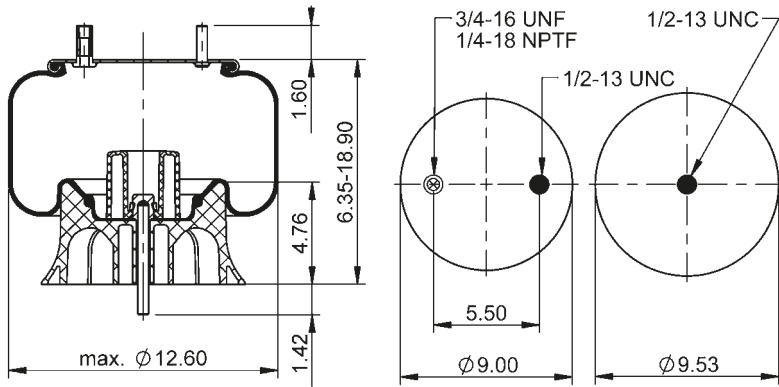

64483



**lb** 12.0 lb **No.** 9308128

**Cross-reference | Cruce de Referencia**  
Firestone W01-358-9484

**Manufacturer | Fabricante**  
SAF Holland 90557158  
90557184

1/4-18 NPTF: max. 22 lb-ft  
1/2-13 UNC: max. 35 lb-ft  
3/4-16 UNF: max. 50 lb-ft

### 9 10-14 A 496

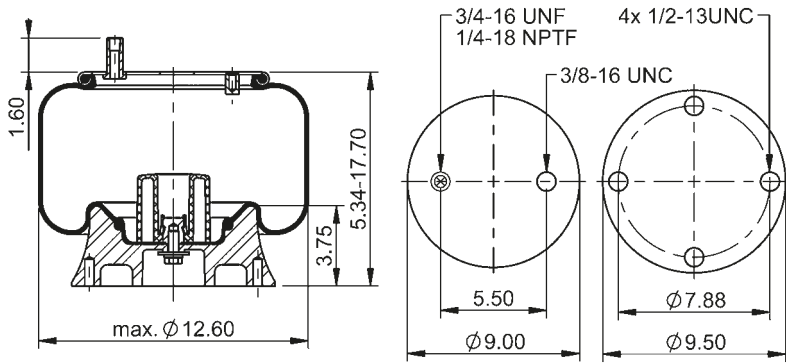

64484



**lb** 14.7 lb **No.** 9309183

**Cross-reference | Cruce de Referencia**  
Firestone W01-358-9797  
Goodyear 1R12-437

**Manufacturer | Fabricante**  
Ridewell 1003589797C

1/4-18 NPTF: max. 22 lb-ft  
1/2-13 UNC: max. 35 lb-ft  
3/4-16 UNF: max. 50 lb-ft

### 9 10-14 P 534

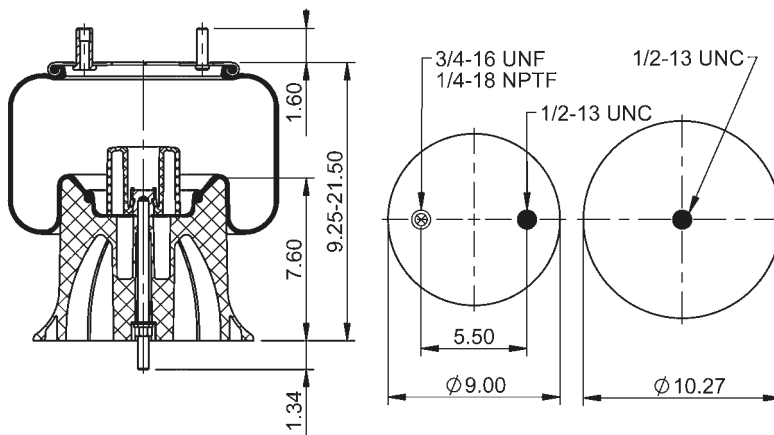

78183



**lb** 14.3 lb **No.** 9306248

**Manufacturer | Fabricante**  
SAF Holland 90557195

1/4-18 NPTF: max. 22 lb-ft  
1/2-13 UNC: max. 35 lb-ft  
3/4-16 UNF: max. 50 lb-ft

### 9 10-14 A 545

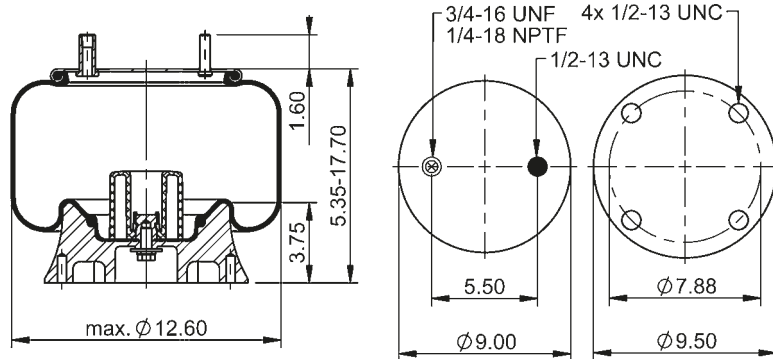

64486



**lb** 14.8 lb **No.** 9309183

**Cross-reference | Cruce de Referencia**

Firestone	W01-358-8806
Goodyear	1R12-445
	1R12-492

**Manufacturer | Fabricante**

Ridewell	1003588806C
Watson & Chalm	AS-0183

1/4-18 NPTF: max. 22 lbft  
 1/2-13 UNC: max. 35 lbft  
 3/4-16 UNF: max. 50 lbft

### 9 10-14 A 546

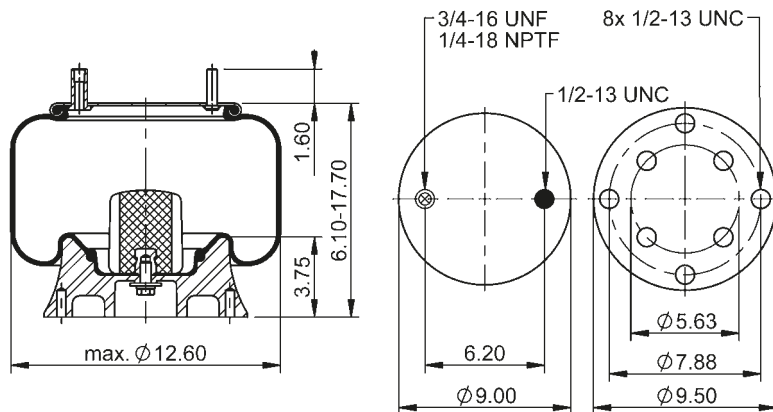

64487



**lb** 16.3 lb **No.** 9309183

**Cross-reference | Cruce de Referencia**

Firestone	W01-358-8810
-----------	--------------

1/4-18 NPTF: max. 22 lbft  
 1/2-13 UNC: max. 35 lbft  
 3/4-16 UNF: max. 50 lbft

### 9 10-14 P 575

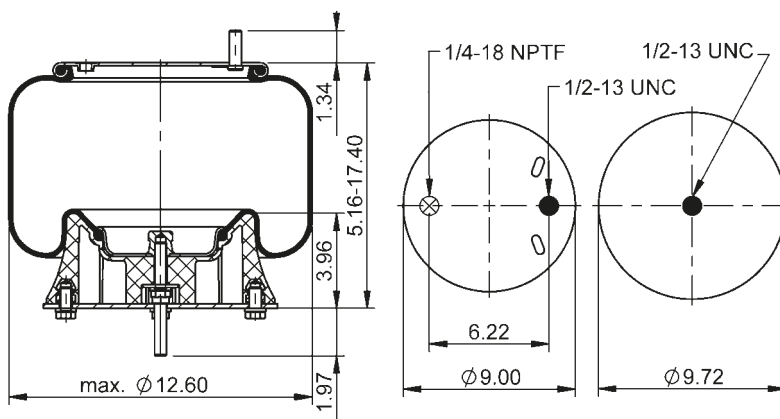

65361



**lb** 14.8 lb **No.** 9312070

**Cross-reference | Cruce de Referencia**

Firestone	W01-358-9634
Goodyear	1R12-636

**Manufacturer | Fabricante**

Freightliner	16-14263-000
	16-14263-001
	16-15443-000
	16-15443-001
	16-15444-000

1/4-18 NPTF: max. 22 lbft  
 1/2-13 UNC: max. 35 lbft  
 3/4-16 UNF: max. 50 lbft

### 9 10-14 P 577

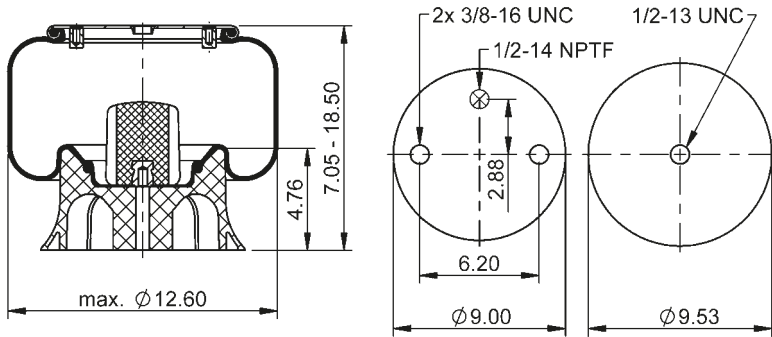

65990



**lb** 13.3 lb **No.** 9308128

**Cross-reference | Cruce de Referencia**

Firestone	W01-358-8813
Goodyear	1R12-1204

**Manufacturer | Fabricante**

Kenworth	C81-1003
	C81-1012
Peterbilt	C81-6000

3/8-16 UNC: max. 20 lb-ft  
 1/2-13 UNC: max. 35 lb-ft  
 1/2-14 NPTF: max. 22 lb-ft

### 9 10-14 P 709

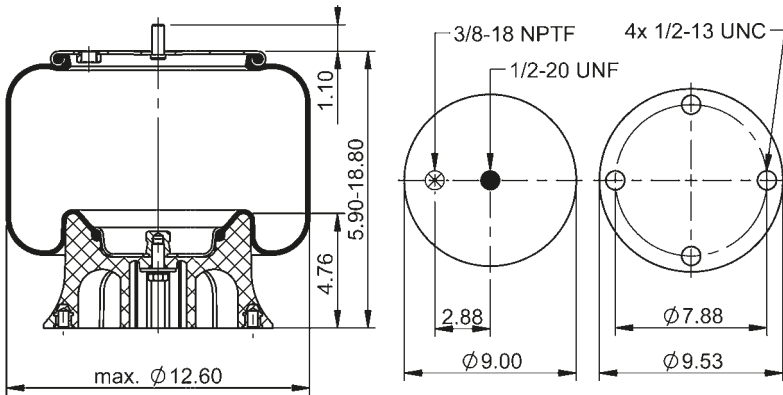

64632



**lb** 11.1 lb **No.** 9308301

**Cross-reference | Cruce de Referencia**

Firestone	W01-W35-9060
Goodyear	1R12-285

**Manufacturer | Fabricante**

New Flyer	65
	14635

3/8-18 NPTF: max. 20 lb-ft  
 1/2-13 UNC: max. 35 lb-ft  
 1/2-20 UNF: max. 35 lb-ft

### 9 10-14 P 718 (BK)

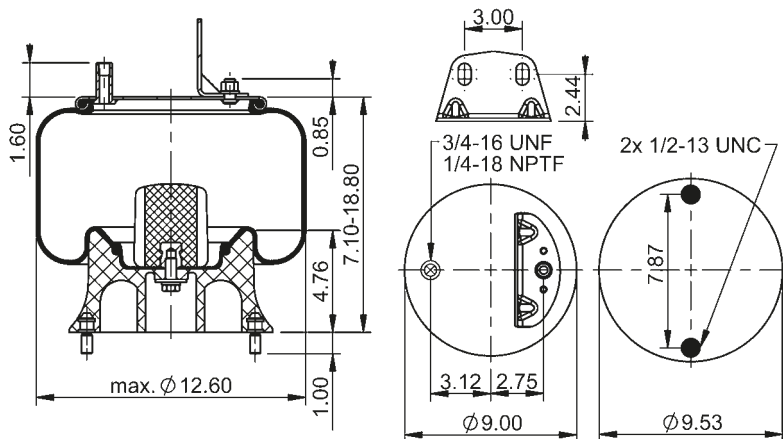

64644



**lb** 13.5 lb **No.** 9308245

**Cross-reference | Cruce de Referencia**

Firestone	W01-358-9507
-----------	--------------

**Manufacturer | Fabricante**

SAF Holland	90557313
-------------	----------

1/4-18 NPTF: max. 22 lb-ft  
 1/2-13 UNC: max. 35 lb-ft  
 3/4-16 UNF: max. 50 lb-ft

### 9 10-14 P 825

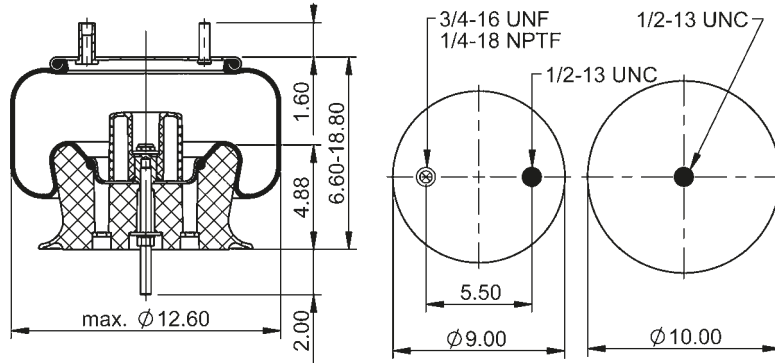

65912



**lb** 13.6 lb **No.** 9308660

**Manufacturer | Fabricante**  
ZF 050121-8174

**1/4-18 NPTF:** max. 22 lb-ft  
**1/2-13 UNC:** max. 35 lb-ft  
**3/4-16 UNF:** max. 50 lb-ft

### 9 10-14 P 875

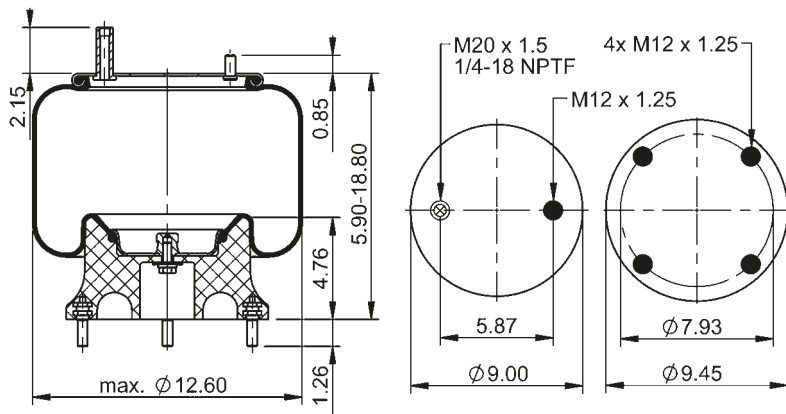

67449



**lb** 12.5 lb **No.** 9312658

**Manufacturer | Fabricante**  
FUSO MK459314

**1/4-18 NPTF:** max. 18 lb-ft  
**M12:** max. 35 lb-ft  
**M20x1.5:** max. 50 lb-ft

### 9 10-14 P 882

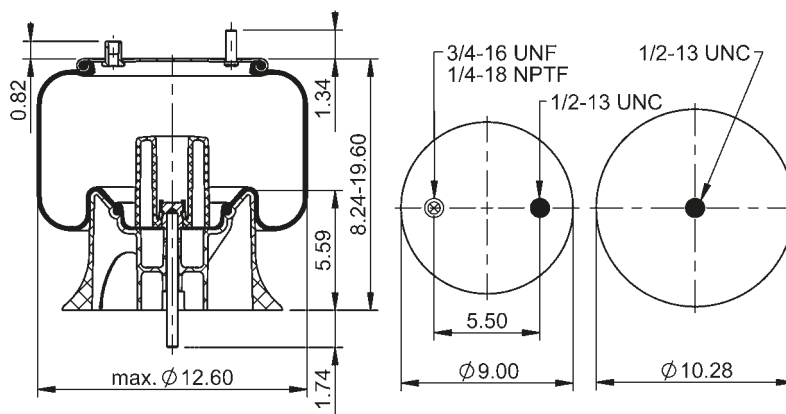

66521



**lb** 13.9 lb **No.** 9314552

**Cross-reference | Cruce de Referencia**  
Firestone W01-358-9697  
Goodyear 1R12-1095

**Manufacturer | Fabricante**  
SAF Holland 90557329  
90557367

**1/4-18 NPTF:** max. 22 lb-ft  
**1/2-13 UNC:** max. 35 lb-ft  
**3/4-16 UNF:** max. 50 lb-ft

### 9 10-14 P 905 (BK)

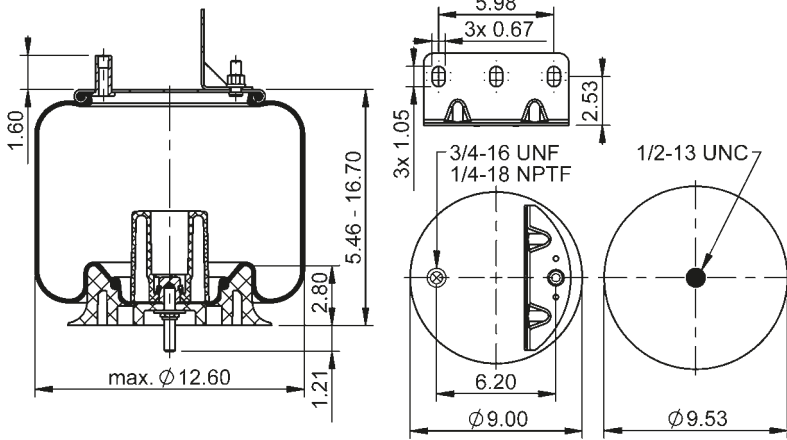

68153



**lb** 13.0 lb **No.** 9308127

**Cross-reference | Cruce de Referencia**  
Firestone W01-358-8816

**Manufacturer | Fabricante**  
Hendrickson 60929-2

**1/4-18 NPTF:** max. 22 lb-ft  
**1/2-13 UNC:** max. 35 lb-ft  
**3/4-16 UNF:** max. 50 lb-ft

### 9 10-14 P 906 (BK)

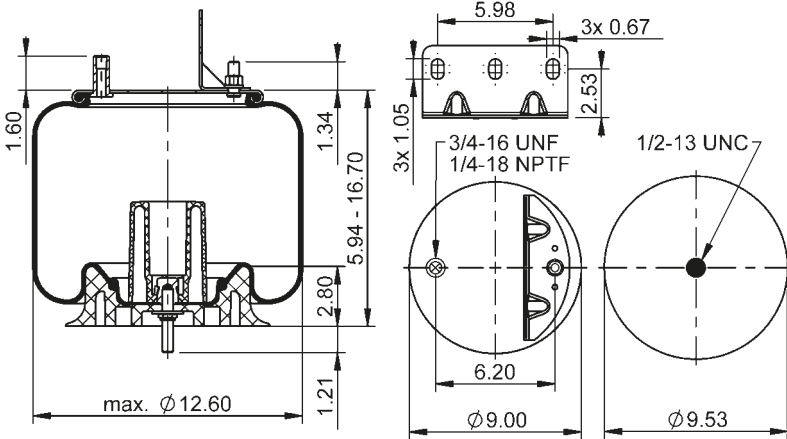

68154



**lb** 13.3 lb **No.** 9308127

**Cross-reference | Cruce de Referencia**  
Firestone W01-358-8817

**Manufacturer | Fabricante**  
Hendrickson 60925-2

**1/4-18 NPTF:** max. 22 lb-ft  
**1/2-13 UNC:** max. 35 lb-ft  
**3/4-16 UNF:** max. 50 lb-ft

### 9 10-14 A 959

**new**

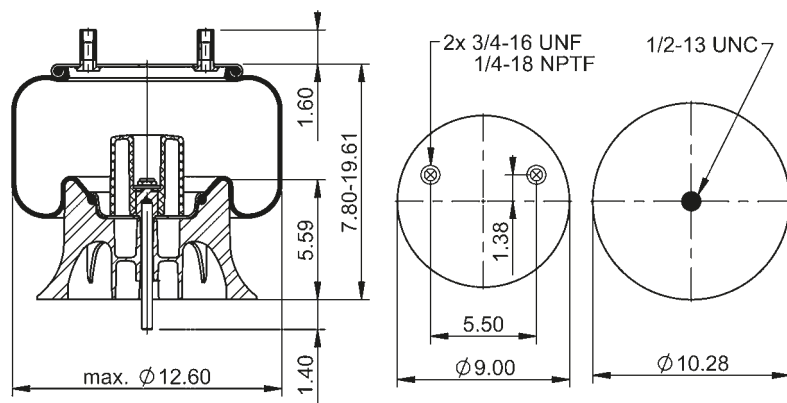

601421



**lb** 16.0 lb **No.** 9313361

**Cross-reference | Cruce de Referencia**  
Goodyear 1R12-1179

**1/4-18 NPTF:** max. 22 lb-ft  
**1/2-13 UNC:** max. 35 lb-ft  
**3/4-16 UNF:** max. 50 lb-ft



### 9 10-14 P 959

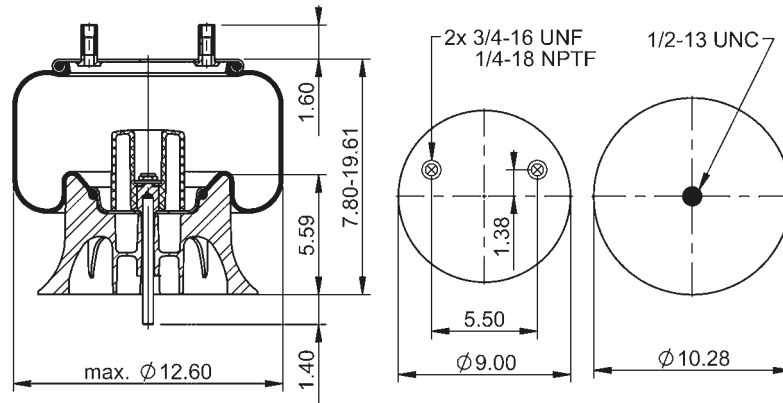

67588



**lb** 13.5 lb **No.** 9314011

**Cross-reference | Cruce de Referencia**  
Firestone W01-358-9978

**Manufacturer | Fabricante**  
Hendrickson S-28929

1/4-18 NPTF: max. 22 lb-ft  
1/2-13 UNC: max. 35 lb-ft  
3/4-16 UNF: max. 50 lb-ft

### 9 10-14 P 1029

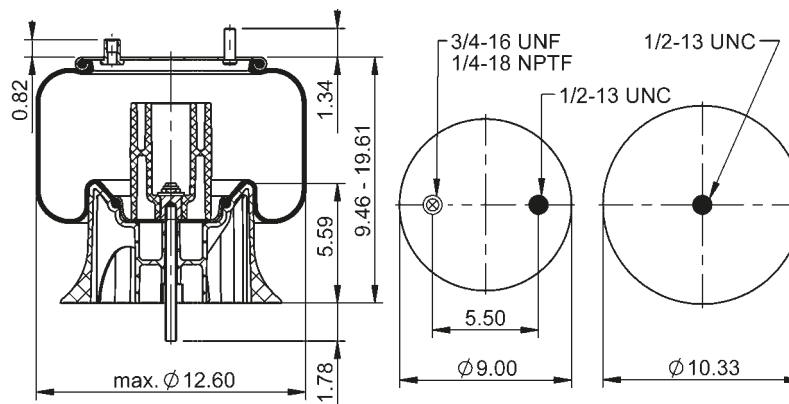

78177



**lb** 15.9 lb **No.** 9314552

**Manufacturer | Fabricante**  
SAF Holland 90557426

1/4-18 NPTF: max. 22 lb-ft  
1/2-13 UNC: max. 35 lb-ft  
3/4-16 UNF: max. 50 lb-ft

### 9 10-14 P 1143

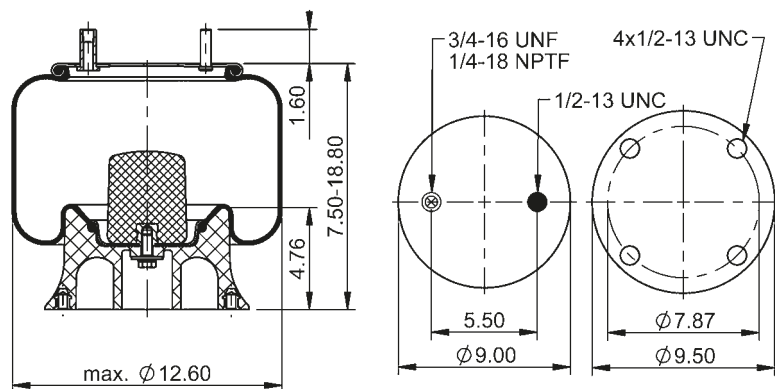

74768



**lb** 13.5 lb **No.** 9308301

**Cross-reference | Cruce de Referencia**  
Firestone W01-W35-8809

**Manufacturer | Fabricante**  
New Flyer 124011

1/4-18 NPTF: max. 22 lb-ft  
1/2-13 UNC: max. 35 lb-ft  
3/4-16 UNF: max. 50 lb-ft

### 9 10-14 P 1189

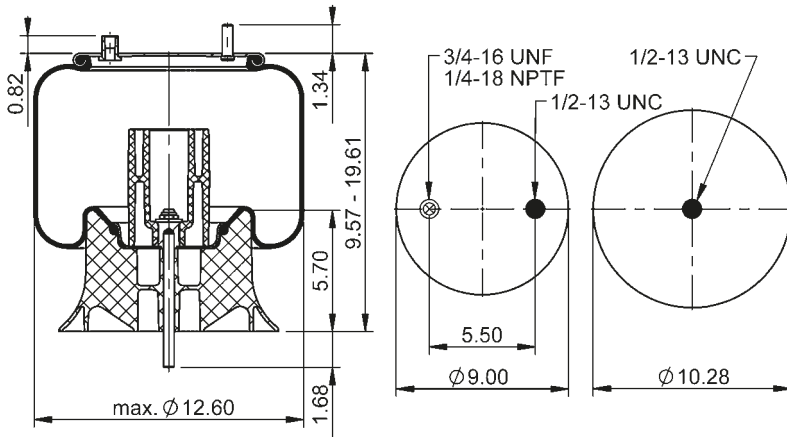

78178



**lb** 13.9 lb **No.** 9314011

**Manufacturer | Fabricante**  
SAF Holland 90557435

**1/4-18 NPTF:** max. 22 lbft  
**1/2-13 UNC:** max. 35 lbft  
**3/4-16 UNF:** max. 50 lbft

### 9 10-14 P 1359

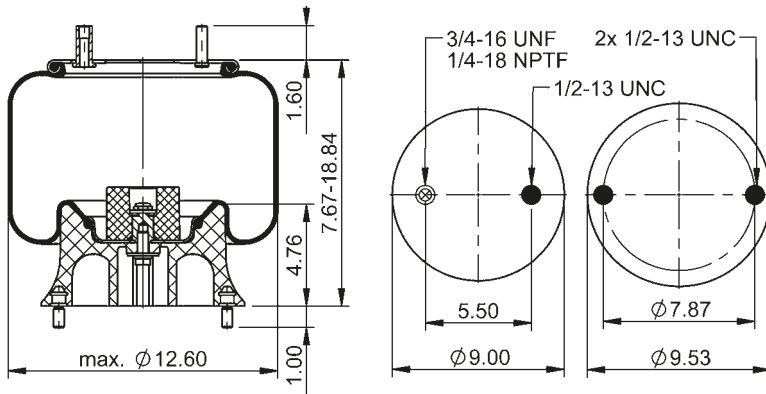

78328



**lb** 13.9 lb **No.** 9308245

**Manufacturer | Fabricante**  
SAF Holland 90557321

**1/4-18 NPTF:** max. 22 lbft  
**1/2-13 UNC:** max. 35 lbft  
**3/4-16 UNF:** max. 50 lbft

### 9 10-14 PT75 (BK)

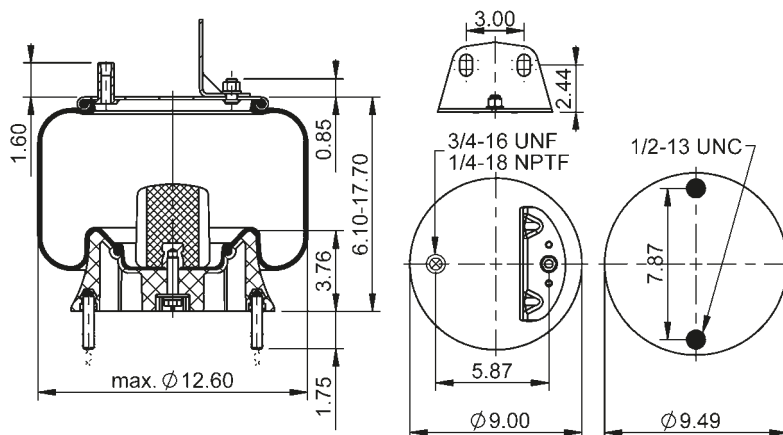

64621



**lb** 14.4 lb **No.** 9312070

**Cross-reference | Cruce de Referencia**  
Firestone W01-358-9507  
Goodyear 1R12-543

**Manufacturer | Fabricante**  
SAF Holland 90557275

**1/4-18 NPTF:** max. 22 lbft  
**1/2-13 UNC:** max. 35 lbft  
**3/4-16 UNF:** max. 50 lbft

### 9 10BS-14 S 1096

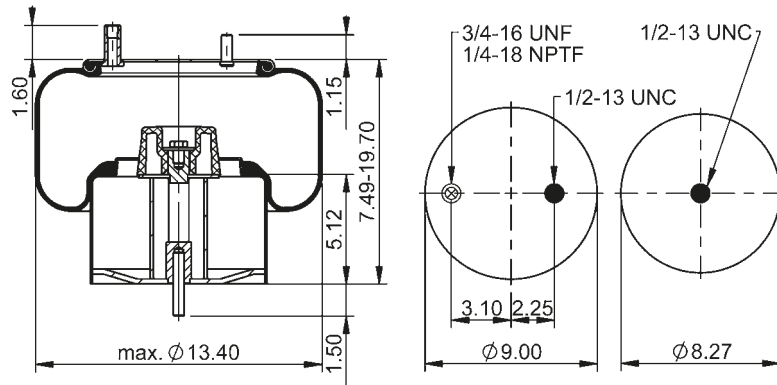

78243



**lb** 20.1 lb **No.** 9317374

**Manufacturer | Fabricante**  
Hendrickson 13676

**1/4-18 NPTF:** max. 22 lb-ft  
**1/2-13 UNC:** max. 35 lb-ft  
**3/4-16 UNF:** max. 50 lb-ft

### 9 10SW-14 S 1208 (BK)

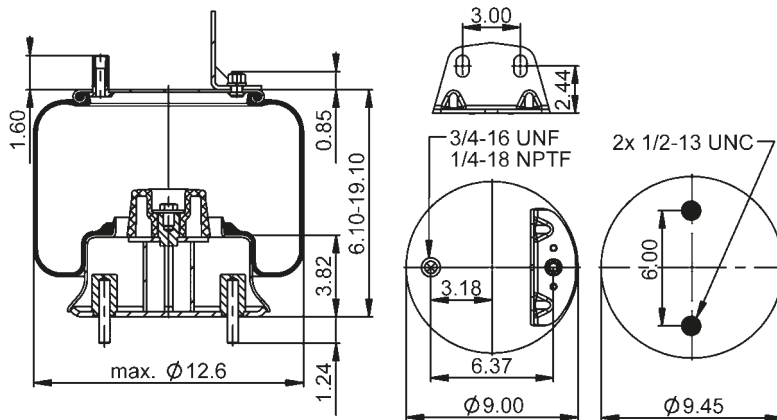

78249



**lb** 20.9 lb **No.** 9318217

**Manufacturer | Fabricante**  
Hendrickson 78546-000

**1/4-18 NPTF:** max. 22 lb-ft  
**1/2-13 UNC:** max. 35 lb-ft  
**3/4-16 UNF:** max. 50 lb-ft

### 9 10SW-14 S 1574 (BK)

**new**

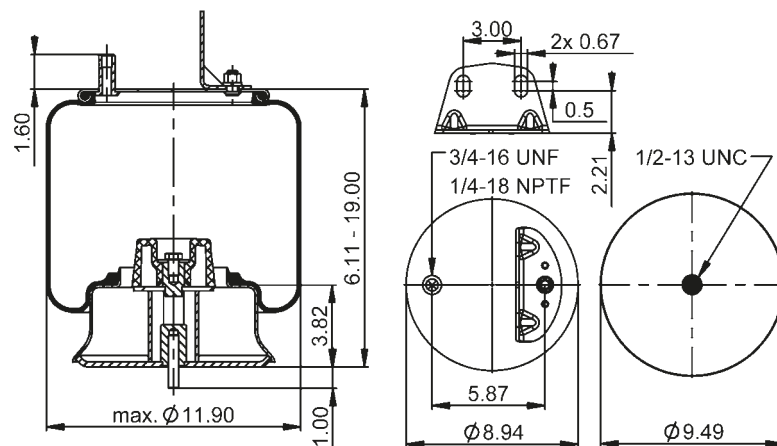

600932



**lb** 20.3 lb **No.** 9317525

**Cross-reference | Cruce de Referencia**  
Firestone W01-358-8184

**Manufacturer | Fabricante**  
SAF Holland 90557290

**1/4-18 NPTF:** max. 22 lb-ft  
**1/2-13 UNC:** max. 35 lb-ft  
**3/4-16 UNF:** max. 50 lb-ft

### 9 10-16 A 310

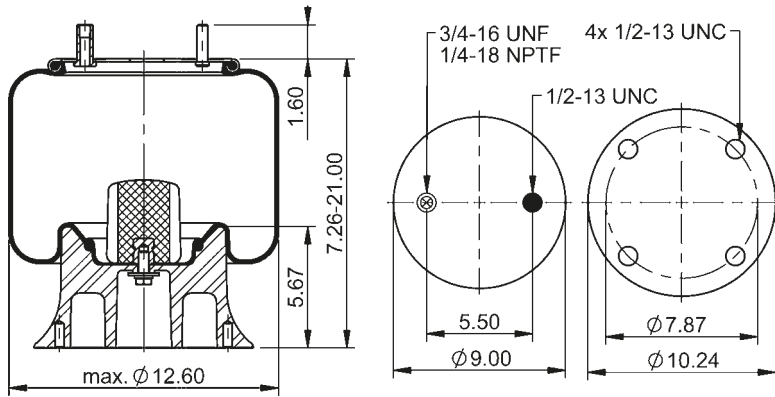

### 70115



**lb** 16.9 lb **No.** 9305199

#### Cross-reference | Cruce de Referencia

Goodyear 1R12-509

#### Manufacturer | Fabricante

Meritor 201869  
Hendrickson S-4041  
S-2066  
B-12514-007  
36514-7  
SAF Holland 90557006  
Volvo 3130491  
Watson & Chalin AS-0011  
and more

1/4-18 NPTF: max. 22 lb-ft  
1/2-13 UNC: max. 35 lb-ft  
3/4-16 UNF: max. 50 lb-ft

### 9 10-16 P 310

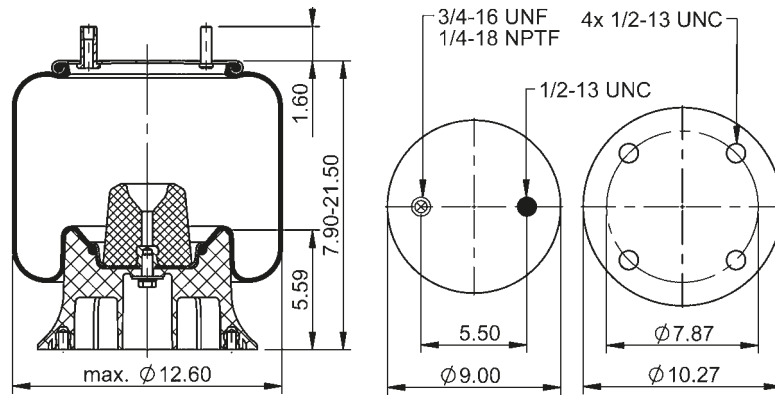

### 64269



**lb** 14.9 lb **No.** 9308133

#### Cross-reference | Cruce de Referencia

Firestone W01-358-9082  
Goodyear 1R12-092

#### Manufacturer | Fabricante

Meritor 201869  
Hendrickson S-2066  
S-4041  
B-12514-007  
36514-7  
SAF Holland 90557006  
Volvo 3130491  
Watson & Chalin AS-0011  
and more

1/4-18 NPTF: max. 22 lb-ft  
1/2-13 UNC: max. 35 lb-ft  
3/4-16 UNF: max. 50 lb-ft

### 9 10-16 P 325

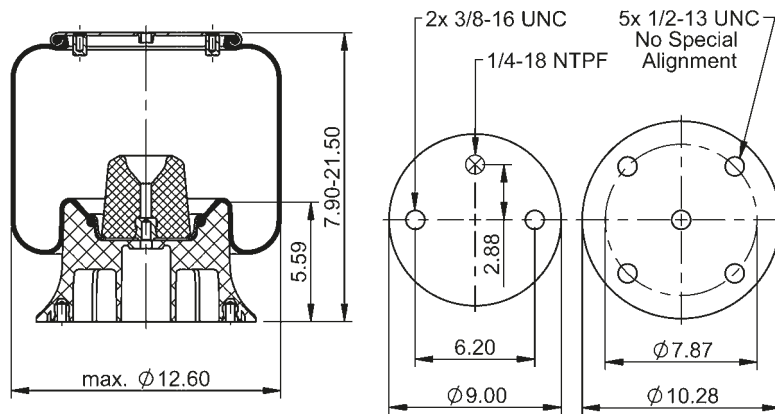

### 64292



**lb** 15.0 lb **No.** 9308133

#### Cross-reference | Cruce de Referencia

Firestone W01-358-9096  
Goodyear 1R12-358  
1R12-155

#### Manufacturer | Fabricante

Dayton 352-9096  
Fruehauf UCE-1304-1  
Hendrickson S-13049  
Loadguard SC2051  
SC2765  
Navistar/Fleetrite 554771C1  
Ridewell 1003589096C  
SAF Holland 57009096  
and more

1/4-18 NPTF: max. 22 lb-ft  
3/8-16 UNC: max. 20 lb-ft  
1/2-13 UNC: max. 35 lb-ft

### 9 10-16 P 332

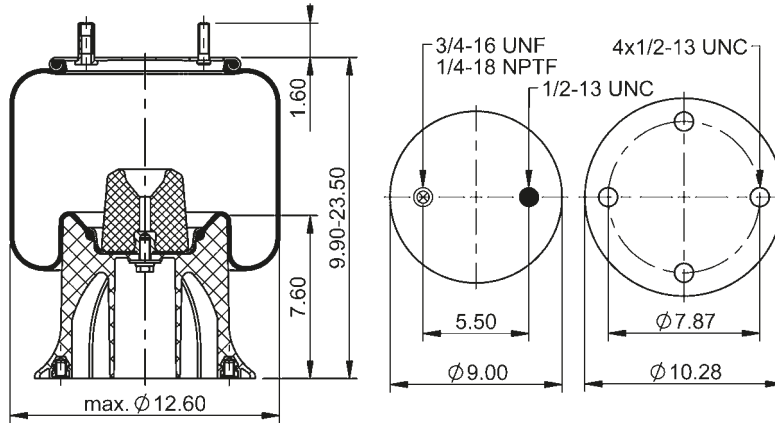

64293



**lb** 16.4 lb **No.** 9308129

**Cross-reference | Cruce de Referencia**

Firestone W01-358-9093  
Goodyear 1R12-621

**Manufacturer | Fabricante**

Meritor 202219  
SAF Holland 90557007  
90557032  
90557035  
Taurus AS504-9093

1/4-18 NPTF: max. 22 lb-ft  
1/2-13 UNC: max. 35 lb-ft  
3/4-16 UNF: max. 50 lb-ft

### 9 10-16 P 333

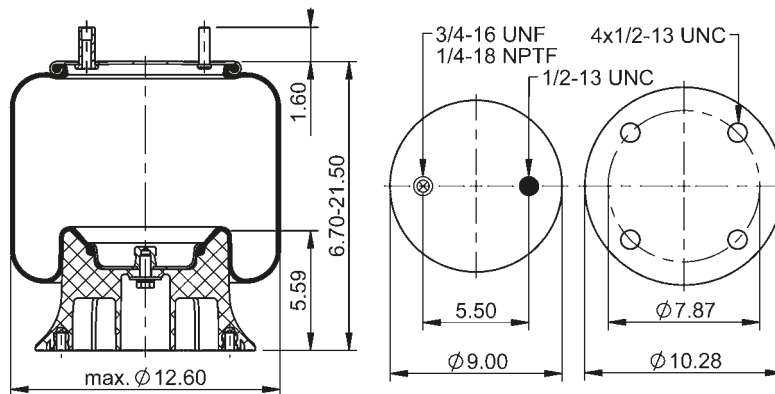

64294



**lb** 14.9 lb **No.** 9308133

**Cross-reference | Cruce de Referencia**

Firestone W01-358-9083  
Goodyear 1R12-066

**Manufacturer | Fabricante**

Hendrickson S-1561  
S-13042  
Loadguard SC2036  
Navistar/Fleetrite 554763C1  
SAF Holland 57009083  
Tuthill 1359  
Watson & Chalin AS-0018  
AS-0028

and more

1/4-18 NPTF: max. 22 lb-ft  
1/2-13 UNC: max. 35 lb-ft  
3/4-16 UNF: max. 50 lb-ft

### 9 10-16 P 351

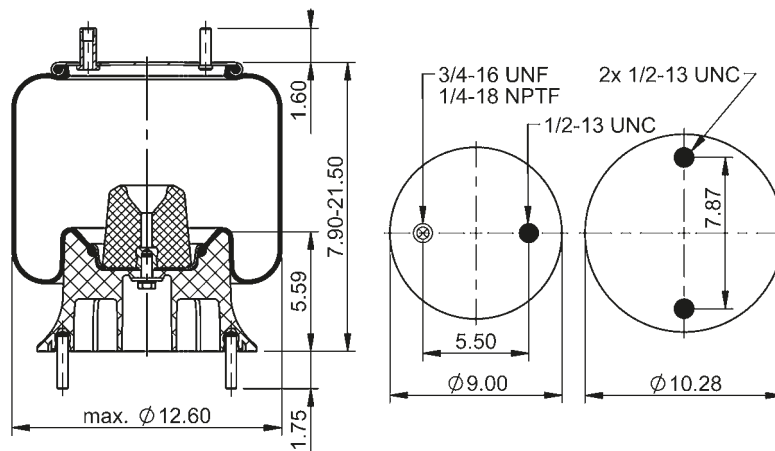

64296



**lb** 15.0 lb **No.** 9308133

**Cross-reference | Cruce de Referencia**

Firestone W01-358-9193

**Manufacturer | Fabricante**

SAF Holland 90557101

1/4-18 NPTF: max. 22 lb-ft  
1/2-13 UNC: max. 35 lb-ft  
3/4-16 UNF: max. 50 lb-ft

### 9 10-16 P 352

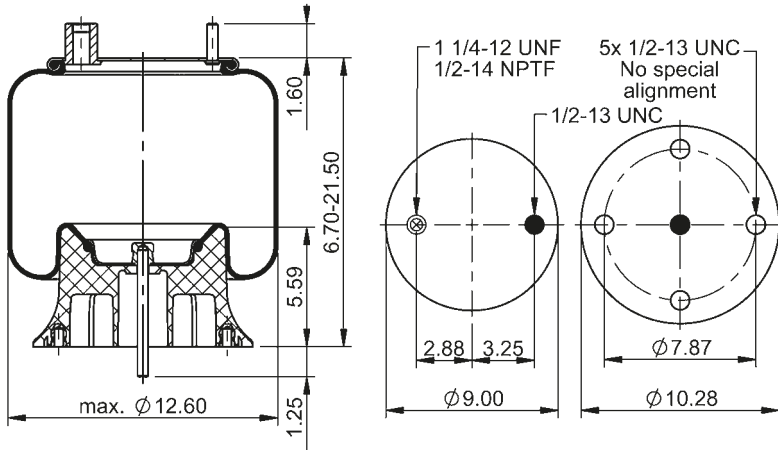

### 64297



**lb** 13.1 lb **No.** 9308133

#### Cross-reference | Cruce de Referencia

Firestone W01-358-9194  
Goodyear 1R12-356

#### Manufacturer | Fabricante

Brake & Wheel M3539  
Dayton 352-9194  
Hendrickson S-13163  
Loadguard SC2786  
Peterbilt 03-05107  
SAF Holland 57009194  
Taurus AS506-9194  
Watson & Chalin AS-0101

1/2-13 UNC: max. 35 lbft  
1/2-14 NPTF: max. 22 lbft  
1 1/4-12 UNF: max. 50 lbft

### 9 10-16 P 353

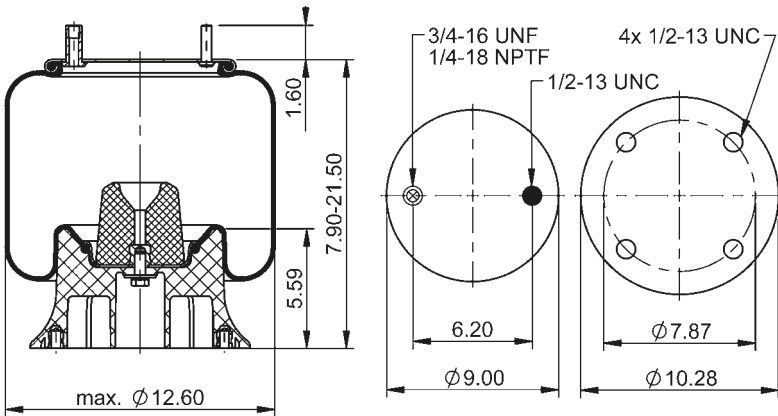

### 64298



**lb** 14.9 lb **No.** 9308133

#### Cross-reference | Cruce de Referencia

Firestone W01-358-9227  
Goodyear 1R12-130

#### Manufacturer | Fabricante

Dayton 352-9227  
Hendrickson S-2924  
48195-1

1/4-18 NPTF: max. 22 lbft  
1/2-13 UNC: max. 35 lbft  
3/4-16 UNF: max. 50 lbft

### 9 10-16 A 354

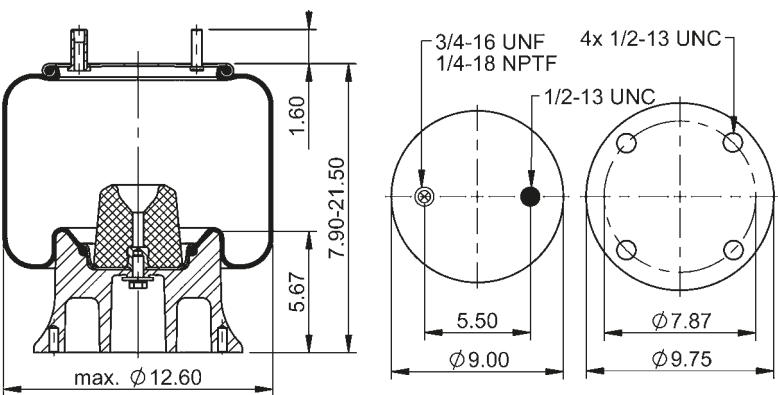

### 64299



**lb** 16.7 lb **No.** 9311400

#### Cross-reference | Cruce de Referencia

Firestone W01-358-9228

#### Manufacturer | Fabricante

Hendrickson B-3411  
Sauer P50-733B  
Watson & Chalin AS-0083

1/4-18 NPTF: max. 22 lbft  
1/2-13 UNC: max. 35 lbft  
3/4-16 UNF: max. 50 lbft

### 9 10-16 P 371

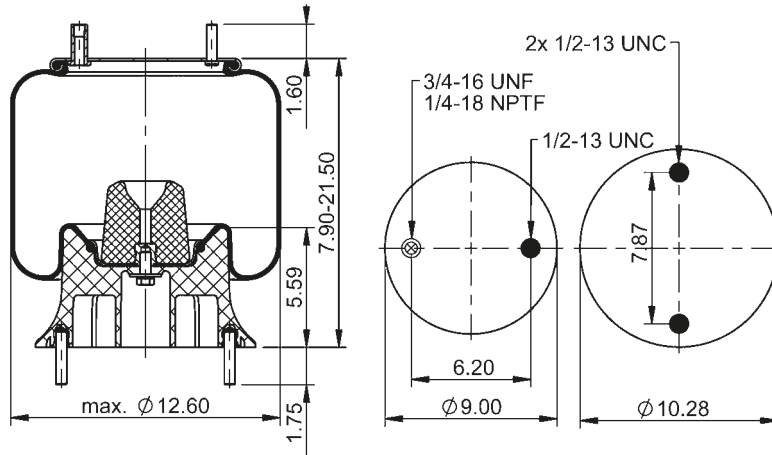

64300



**lb** 15.0 lb **No.** 9308133

**Cross-reference | Cruce de Referencia**  
 Firestone W01-358-9256

**Manufacturer | Fabricante**  
 Hendrickson 49160

1/4-18 NPTF: max. 22 lb-ft  
 1/2-13 UNC: max. 35 lb-ft  
 3/4-16 UNF: max. 50 lb-ft

### 9 10-16 P 372

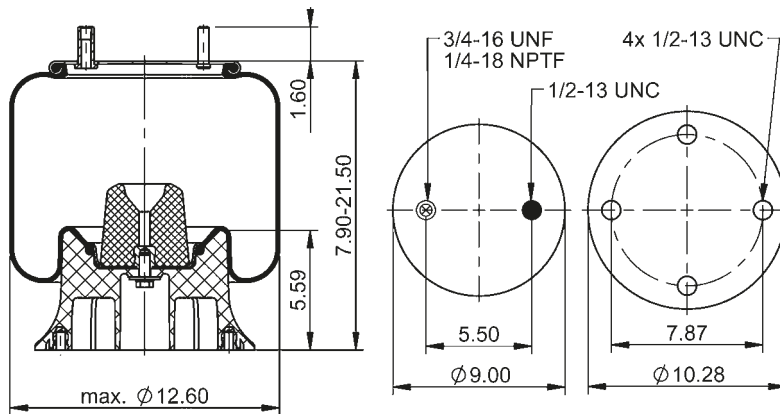

64301



**lb** 14.9 lb **No.** 9308133

**Cross-reference | Cruce de Referencia**  
 Firestone W01-358-9092  
 Goodyear 1R12-220

**Manufacturer | Fabricante**  
 Hendrickson S-12353  
 Loadguard SC2767  
 Navistar/Fleetrite 517096C91  
 SAF Holland 90557031

1/4-18 NPTF: max. 22 lb-ft  
 1/2-13 UNC: max. 35 lb-ft  
 3/4-16 UNF: max. 50 lb-ft

### 9 10-16 P 376

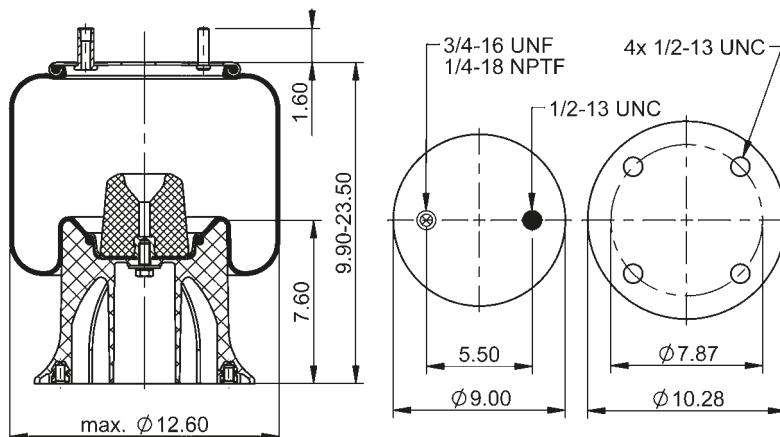

64302



**lb** 16.4 lb **No.** 9308129

**Cross-reference | Cruce de Referencia**  
 Firestone W01-358-9392  
 Goodyear 1R12-143

**Manufacturer | Fabricante**  
 Hendrickson B-4773

1/4-18 NPTF: max. 22 lb-ft  
 1/2-13 UNC: max. 35 lb-ft  
 3/4-16 UNF: max. 50 lb-ft

### 9 10-16 P 391

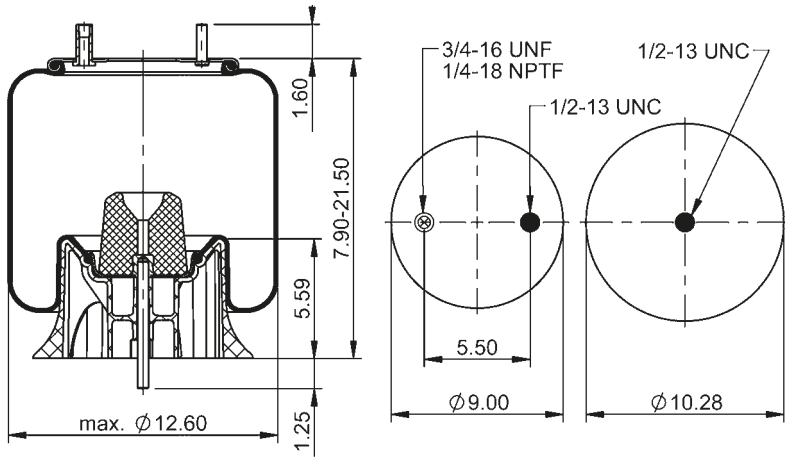

64304



**lb** 14.1 lb **No.** 9314552

**Cross-reference | Cruce de Referencia**

Firestone W01-358-9362  
Goodyear 1R12-441

**Manufacturer | Fabricante**

SAF Holland 90557113  
Silent Drive AS-9362  
Watson & Chalin AS-0049

- 1/4-18 NPTF: max. 22 lb-ft
- 1/2-13 UNC: max. 35 lb-ft
- 3/4-16 UNF: max. 50 lb-ft

### 9 10-16 P 392

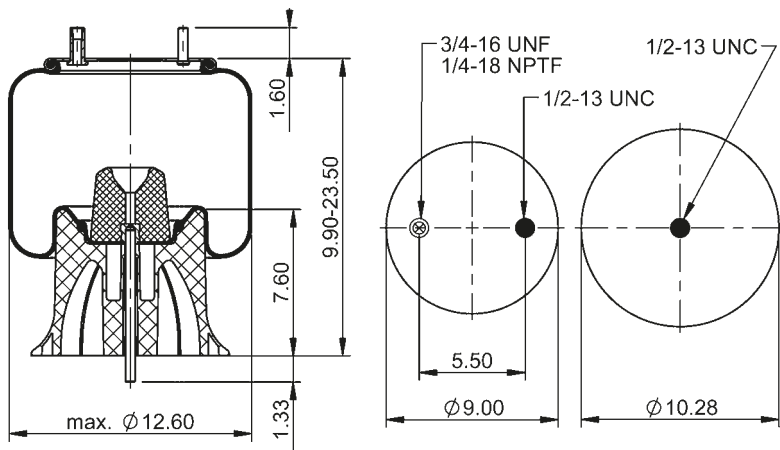

64305



**lb** 16.0 lb **No.** 9306248

**Cross-reference | Cruce de Referencia**

Firestone W01-358-9304  
W01-358-9364

**Manufacturer | Fabricante**

SAF Holland 90557124  
Watson & Chalin AS-0059

- 1/4-18 NPTF: max. 22 lb-ft
- 1/2-13 UNC: max. 35 lb-ft
- 3/4-16 UNF: max. 50 lb-ft

### 9 10-16 P 393

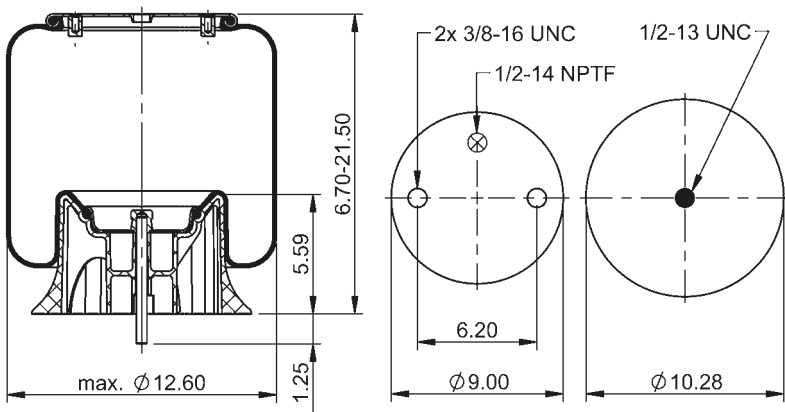

64306



**lb** 12.0 lb **No.** 9314552

**Cross-reference | Cruce de Referencia**

Firestone W01-358-9026  
Goodyear 1R12-567

**Manufacturer | Fabricante**

Peterbilt 03-06213  
03-07111

- 3/8-16 UNC: max. 20 lb-ft
- 1/2-13 UNC: max. 35 lb-ft
- 1/2-14 NPTF: max. 22 lb-ft



### 9 10-16 P 394

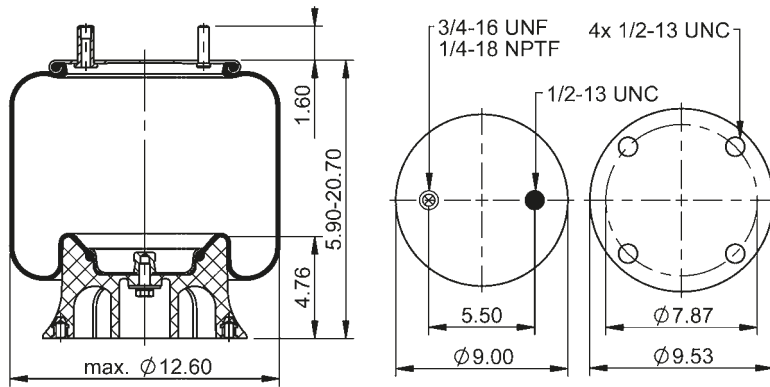

64307



**lb** 11.5 lb **No.** 9308301

**Cross-reference | Cruce de Referencia**  
Firestone W01-358-9004

**Manufacturer | Fabricante**  
Watson & Chalin AS-0043

**1/4-18 NPTF:** max. 22 lb-ft  
**1/2-13 UNC:** max. 35 lb-ft  
**3/4-16 UNF:** max. 50 lb-ft

### 9 10-16 P 407

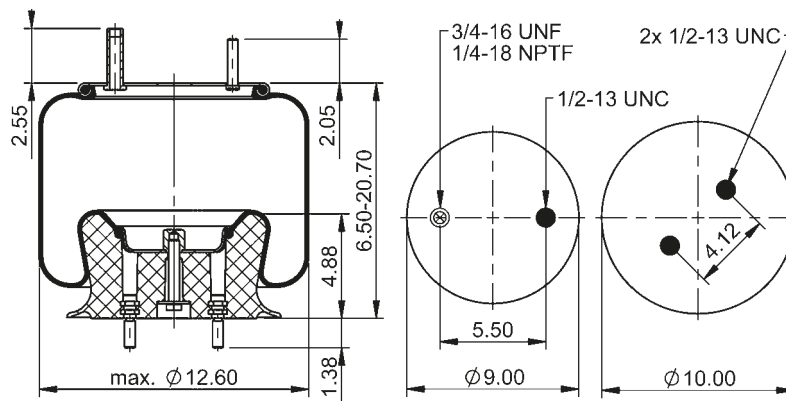

64262



**lb** 13.3 lb **No.** 9308663

**Cross-reference | Cruce de Referencia**  
Goodyear 1R12-090

**Manufacturer | Fabricante**  
Loadguard SC2048  
Navistar/Fleetrite 501159C2  
501559C1  
1660581C1  
Volvo 85101156

**1/4-18 NPTF:** max. 22 lb-ft  
**1/2-13 UNC:** max. 35 lb-ft  
**3/4-16 UNF:** max. 50 lb-ft

### 9 10-16 P 408

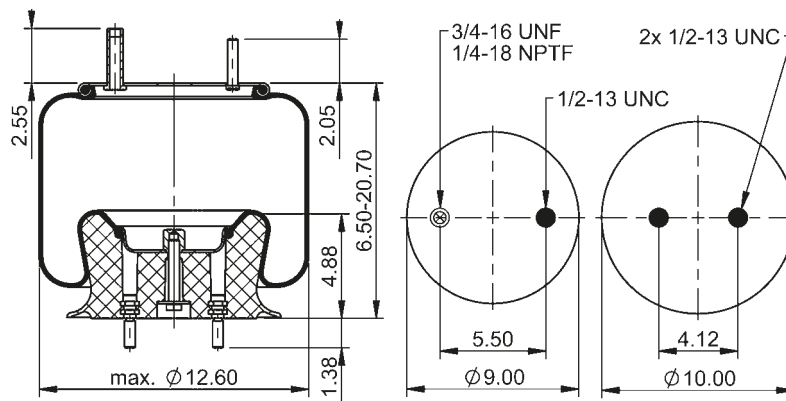

64259



**lb** 13.3 lb **No.** 9308663

**Cross-reference | Cruce de Referencia**  
Firestone W01-358-9219  
Goodyear 1R12-151  
1R12-182

**Manufacturer | Fabricante**  
SAF Holland 57009219  
Volvo 350033201  
350033203  
350033204  
350033209  
352233203  
Navistar/Fleetrite 1672401C1  
1681739C1

and more  
**1/4-18 NPTF:** max. 22 lb-ft  
**1/2-13 UNC:** max. 35 lb-ft  
**3/4-16 UNF:** max. 50 lb-ft

### 9 10-16 P 409

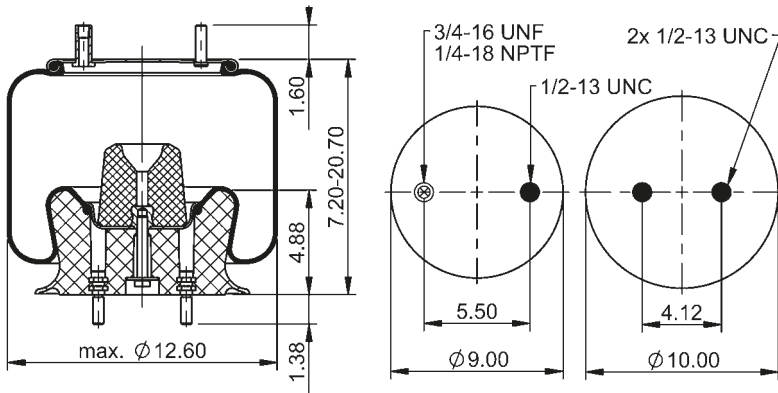

### 64275



**lb** 15.4 lb **No.** 9308663

#### Cross-reference | Cruce de Referencia

Firestone	W01-358-9223
Goodyear	1R12-188

#### Manufacturer | Fabricante

Hendrickson	48195-2
Reyco	12884-01
	12884-01A
Ridewell	1003589223C
SAF Holland	57009223

1/4-18 NPTF: max. 22 lb-ft  
 1/2-13 UNC: max. 35 lb-ft  
 3/4-16 UNF: max. 50 lb-ft

### 9 10-16 P 410

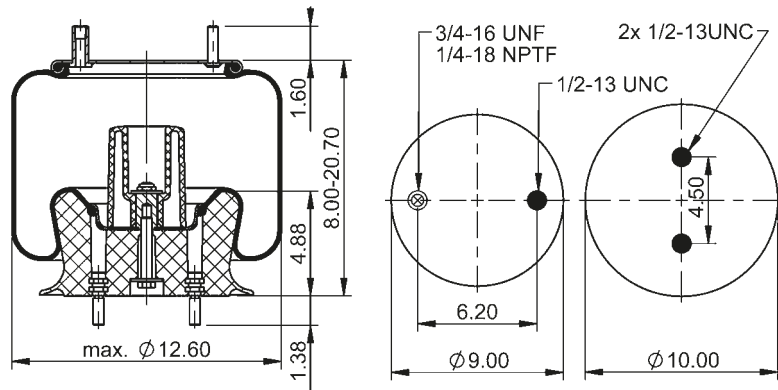

### 64276



**lb** 14.7 lb **No.** 9308662

#### Cross-reference | Cruce de Referencia

Firestone	W01-358-9466
Goodyear	1R12-365

#### Manufacturer | Fabricante

Ford	E9HZ5580A
Hendrickson	49048-2
	49674-1
	49674-2
Mack	364QS28
	57QL411M
Volvo	85101157
	350034409

and more

1/4-18 NPTF: max. 22 lb-ft  
 1/2-13 UNC: max. 35 lb-ft  
 3/4-16 UNF: max. 50 lb-ft

### 9 10-16 P 416 (BK)

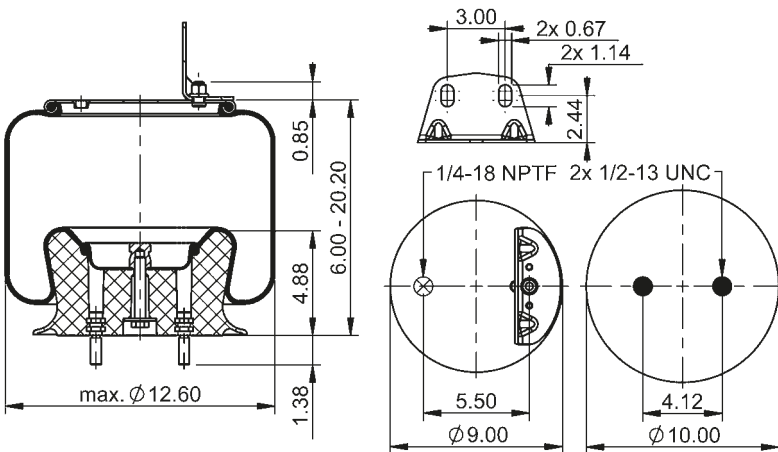

### 69643



**lb** 13.1 lb **No.** 9308663

#### Cross-reference | Cruce de Referencia

Firestone	W01-358-9296
Goodyear	1R12-400

#### Manufacturer | Fabricante

Loadguard	SC2760
Volvo	8061151
	8169868

1/4-18 NPTF: max. 22 lb-ft  
 1/2-13 UNC: max. 35 lb-ft

### 9 10-16 P 441

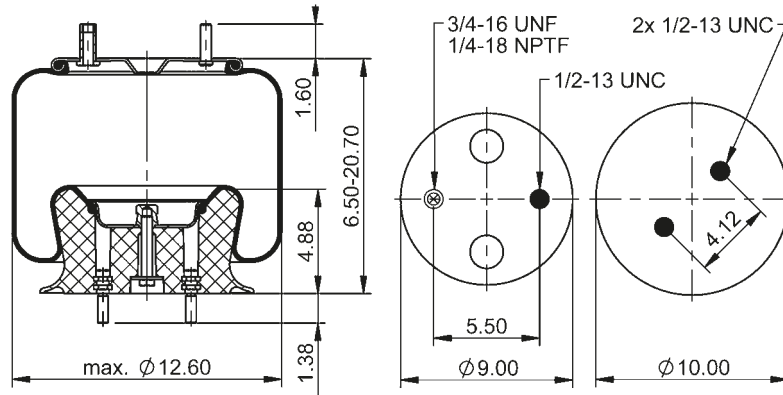

64308



**lb** 13.2 lb **No.** 9308663

**Cross-reference | Cruce de Referencia**  
Firestone W01-358-9213

**Manufacturer | Fabricante**  
Hendrickson S-13033  
Navistar/Fleetrite 501559C2  
1686386C1  
1660581C1  
501559C1  
SAF Holland 57009213  
Volvo 3130495  
Dayton 352-9213  
and more

1/4-18 NPTF: max. 22 lb-ft  
1/2-13 UNC: max. 35 lb-ft  
3/4-16 UNF: max. 50 lb-ft

### 9 10-16 P 497

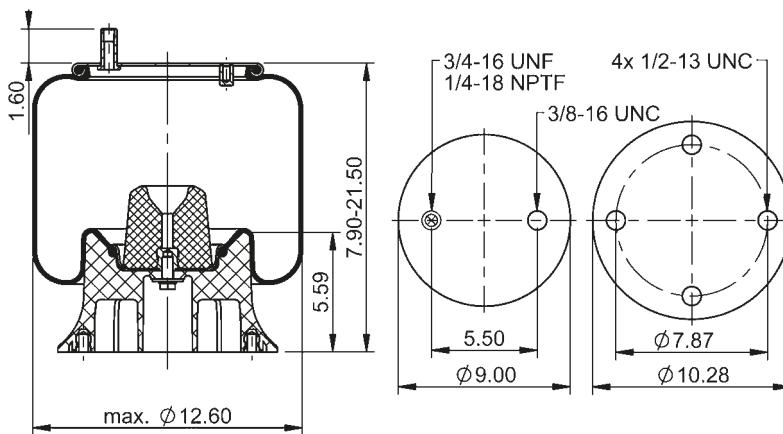

64314



**lb** 14.8 lb **No.** 9308133

**Cross-reference | Cruce de Referencia**  
Firestone W01-358-8924  
Goodyear 1R12-436

**Manufacturer | Fabricante**  
Ridewell 1003588924C

1/4-18 NPTF: max. 22 lb-ft  
1/2-13 UNC: max. 35 lb-ft  
3/4-16 UNF: max. 50 lb-ft

### 9 10-16 P 498

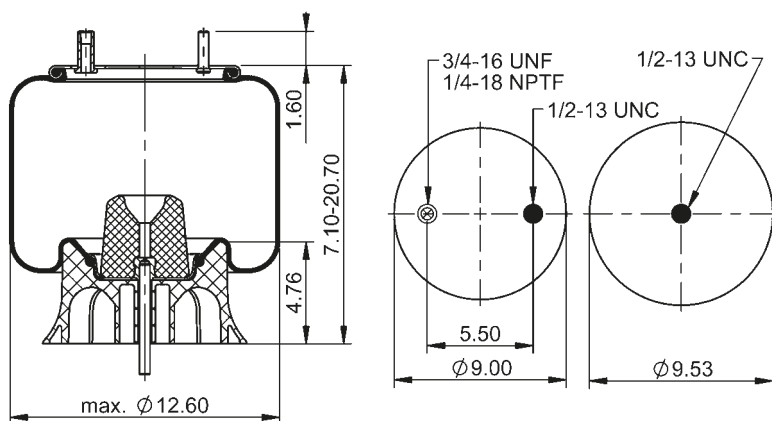

64315



**lb** 13.7 lb **No.** 9308128

**Cross-reference | Cruce de Referencia**  
Firestone W01-358-8927

**Manufacturer | Fabricante**  
Watson & Chalin AS-0062

1/4-18 NPTF: max. 22 lb-ft  
1/2-13 UNC: max. 35 lb-ft  
3/4-16 UNF: max. 50 lb-ft

### 9 10-16 P 500

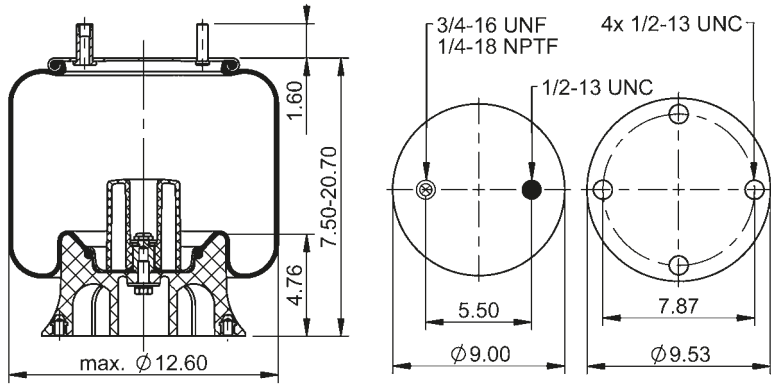

### 64317



**lb** 12.7 lb **No.** 9308301

**Cross-reference | Cruce de Referencia**  
Firestone W01-358-9474

**Manufacturer | Fabricante**  
Eveley RA 1954-11  
Reyco 20966-01

**1/4-18 NPTF:** max. 22 lb-ft  
**1/2-13 UNC:** max. 35 lb-ft  
**3/4-16 UNF:** max. 50 lb-ft

### 9 10-16 P 510

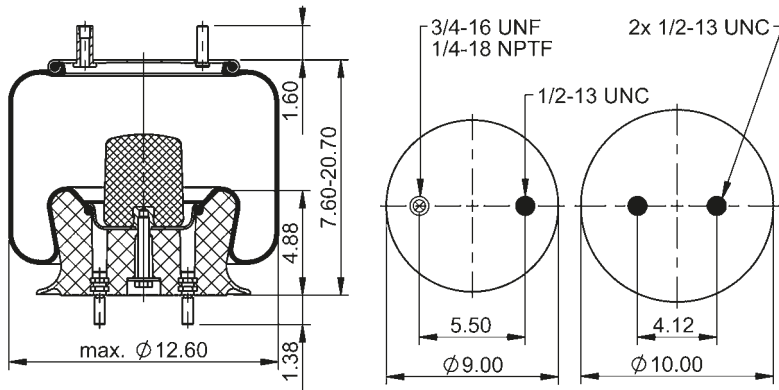

### 64318



**lb** 15.1 lb **No.** 9308663

**Cross-reference | Cruce de Referencia**  
Firestone W01-358-9944

**Manufacturer | Fabricante**  
Reyco 12884-01B

**1/4-18 NPTF:** max. 22 lb-ft  
**1/2-13 UNC:** max. 35 lb-ft  
**3/4-16 UNF:** max. 50 lb-ft

### 9 10-16 P 547 (BK)

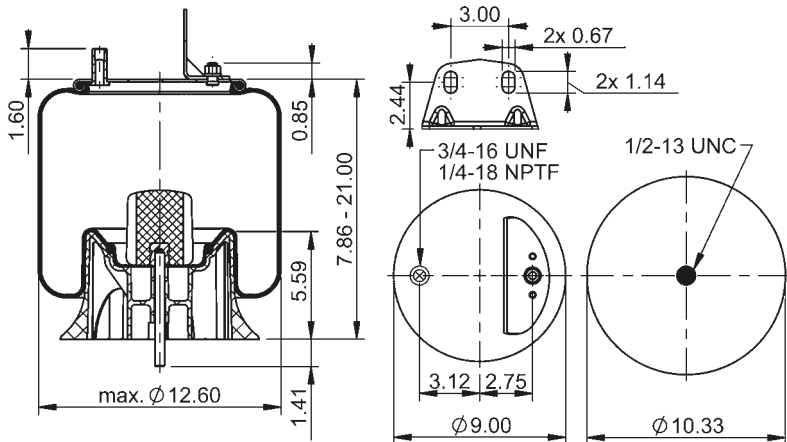

### 69653



**lb** 14.1 lb **No.** 9314552

**Cross-reference | Cruce de Referencia**  
Firestone W01-358-9496

**Manufacturer | Fabricante**  
SAF Holland 90557208

**1/4-18 NPTF:** max. 22 lb-ft  
**1/2-13 UNC:** max. 35 lb-ft  
**3/4-16 UNF:** max. 50 lb-ft

### 9 10-16 P 549 (BK)

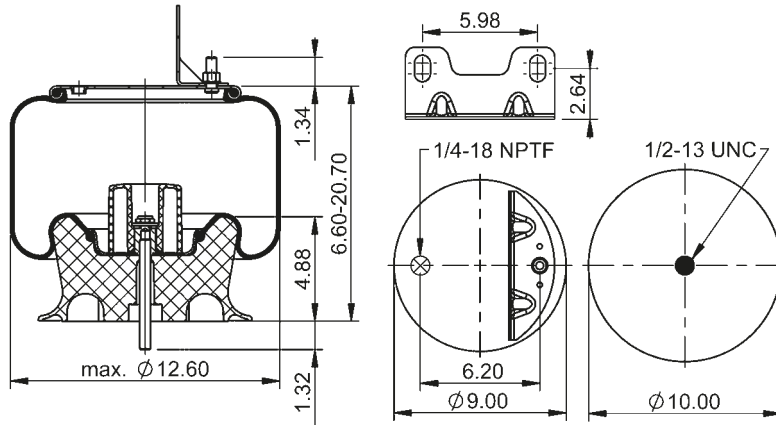

69658



**lb** 13.6 lb **No.** 9308660

**Cross-reference | Cruce de Referencia**  
Firestone W01-358-9643

**Manufacturer | Fabricante**  
Hendrickson 58995-2

1/4-18 NPTF: max. 22 lb-ft  
1/2-13 UNC: max. 35 lb-ft

### 9 10-16 P 710

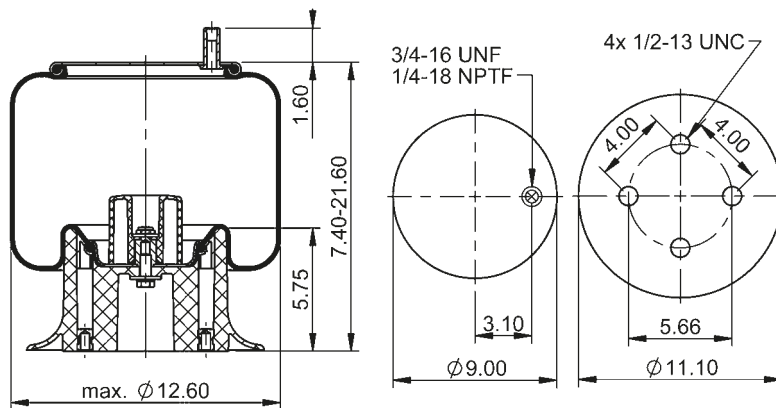

64634



**lb** 13.5 lb **No.** 9308998

**Cross-reference | Cruce de Referencia**  
Firestone W01-358-9299  
Goodyear 1R12-366

**Manufacturer | Fabricante**  
Hendrickson C-20217  
S-20716

1/4-18 NPTF: max. 22 lb-ft  
1/2-13 UNC: max. 35 lb-ft  
3/4-16 UNF: max. 50 lb-ft

### 9 10-16 P 769

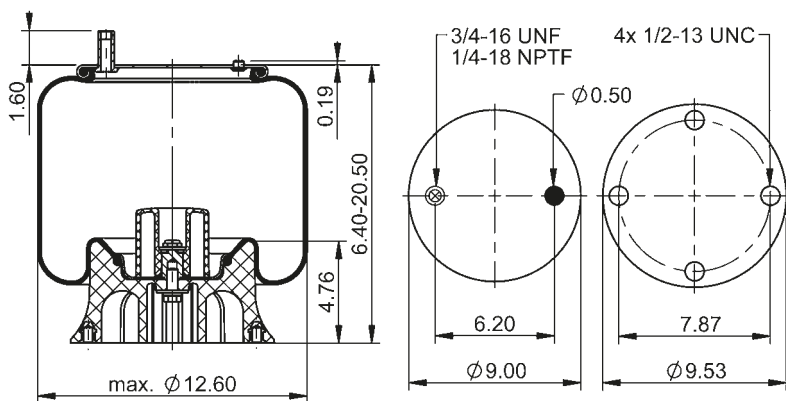

64650



**lb** 13.0 lb **No.** 9308301

**Cross-reference | Cruce de Referencia**  
Firestone W01-358-8825  
Goodyear 1R12-541

**Manufacturer | Fabricante**  
Watson & Chalin AS-0113-G

1/4-18 NPTF: max. 22 lb-ft  
1/2-13 UNC: max. 35 lb-ft  
3/4-16 UNF: max. 50 lb-ft

### 9 10-16 P 770

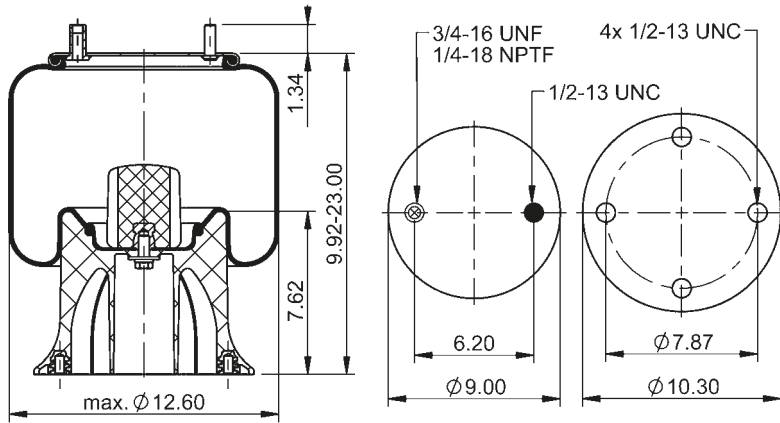

64651



**lb** 16.5 lb **No.** 9308129

**Cross-reference | Cruce de Referencia**  
Goodyear 1R12-576

**Manufacturer | Fabricante**  
Watson & Chalin AS-0125-G

- 1/4-18 NPTF: max. 22 lb-ft
- 1/2-13 UNC: max. 35 lb-ft
- 3/4-16 UNF: max. 50 lb-ft

### 9 10-16 P 841

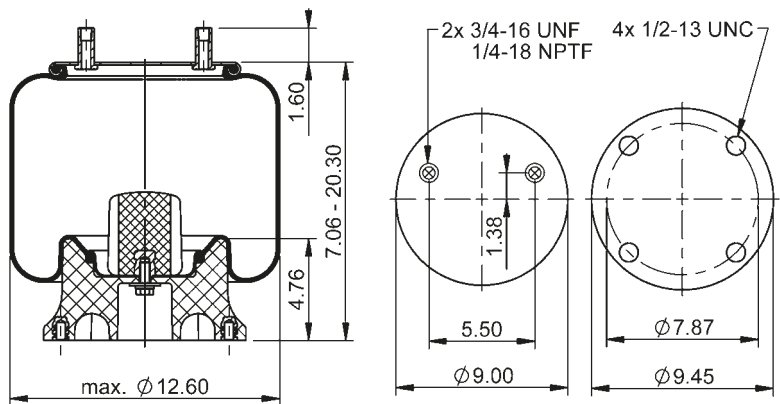

66005



**lb** 13.9 lb **No.** 9308301

**Manufacturer | Fabricante**  
Watson & Chalin AS-0218

- 1/4-18 NPTF: max. 22 lb-ft
- 1/2-13 UNC: max. 35 lb-ft
- 3/4-16 UNF: max. 50 lb-ft

### 9 10-16 P 876

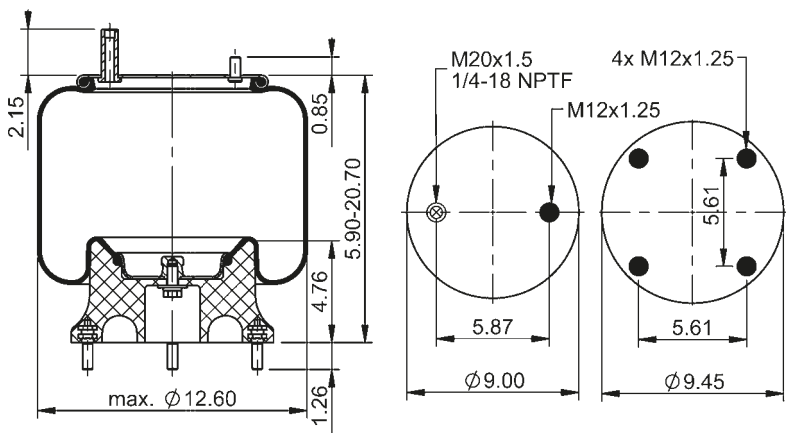

67450



**lb** 11.9 lb **No.** 9312658

**Manufacturer | Fabricante**  
FUSO MK459315

- 1/4-18 NPTF: max. 18 lb-ft
- M12: max. 35 lb-ft
- M20x1.5: max. 50 lb-ft

### 9 10-16 P 1240

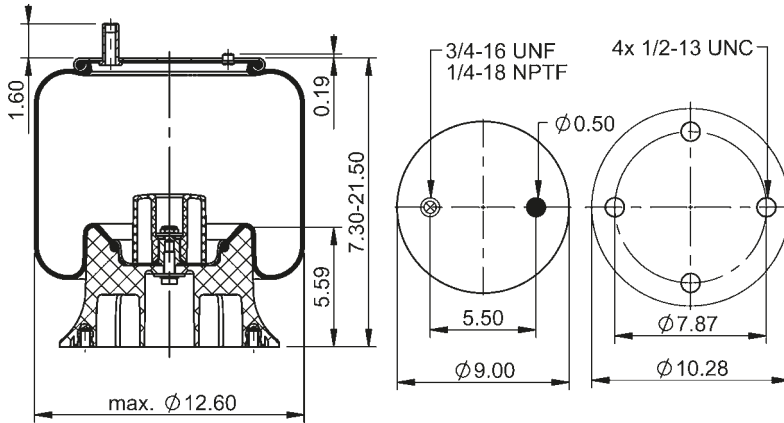

75973



**lb** 14.3 lb **No.** 9308133

**Cross-reference | Cruce de Referencia**  
Goodyear 1R12-584

**Manufacturer | Fabricante**  
Ridewell 1001R12584G  
Watson & Chalin AS-0061-1

1/4-18 NPTF: max. 22 lb-ft  
1/2-13 UNC: max. 35 lb-ft  
3/4-16 UNF: max. 50 lb-ft

### 9 10-16 P 1309

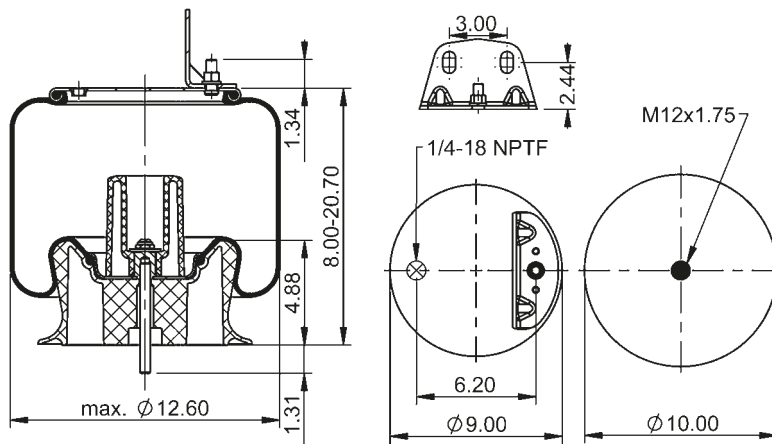

77699



**lb** 14.9 lb **No.** 9313520

**Cross-reference | Cruce de Referencia**  
Firestone W01-358-8591  
Goodyear 1R12-423

**Manufacturer | Fabricante**  
Volvo 3180673

1/4-18 NPTF: max. 22 lb-ft  
M12x1.75: max. 35 lb-ft

### 9 10-16 P 1602

**new**

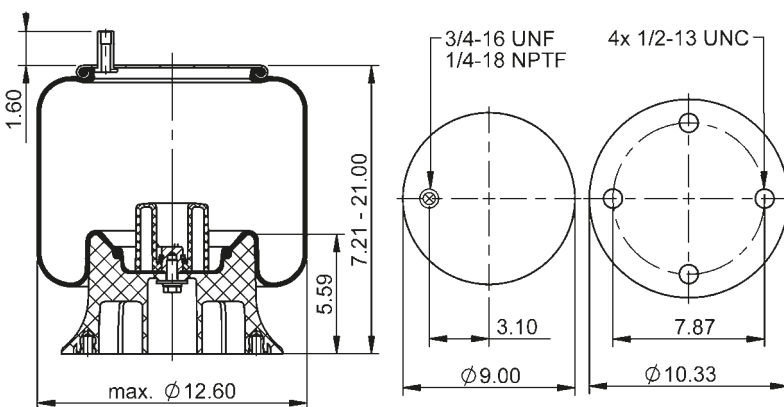

601539



**lb** 13.0 lb **No.** 9308133

**Cross-reference | Cruce de Referencia**  
Firestone W01-358-8824

**Manufacturer | Fabricante**  
Reyco 702614-01  
Tuthill

1/4-18 NPTF: max. 22 lb-ft  
1/2-13 UNC: max. 35 lb-ft  
3/4-16 UNC: max. 50 lb-ft

### 9 10BP-16 P 569

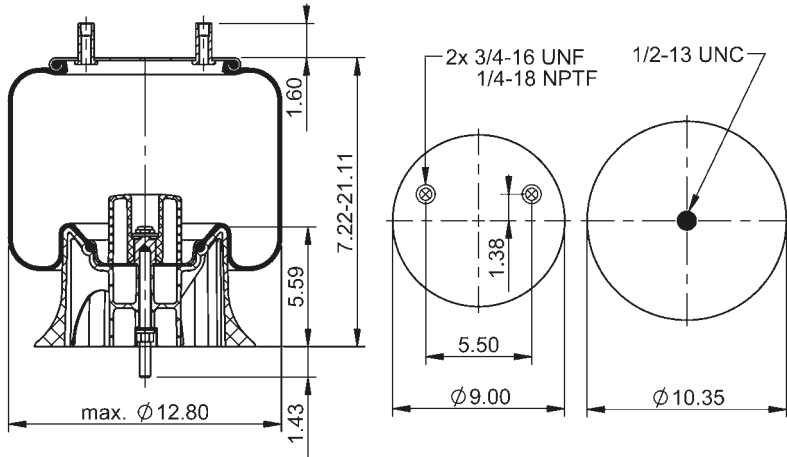

64693



**lb** 12.8 lb **No.** 9314552

**Cross-reference | Cruce de Referencia**  
Firestone W01-358-9644

**Manufacturer | Fabricante**  
Hendrickson S-23721

**1/4-18 NPTF:** max. 22 lb-ft  
**1/2-13 UNC:** max. 35 lb-ft  
**3/4-16 UNF:** max. 50 lb-ft

### 9 10J-16 S 1551

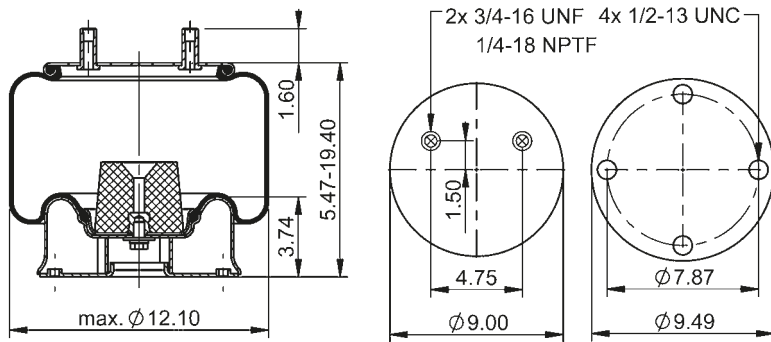

600688



**lb** 19.8 lb **No.** 9311827

**Cross-reference | Cruce de Referencia**  
Goodyear 1R11-232

**1/4-18 NPTF:** max. 18 lb-ft  
**1/2-13 UNC:** max. 35 lb-ft  
**3/4-16 UNF:** max. 50 lb-ft

### 9 10S-16 A 382

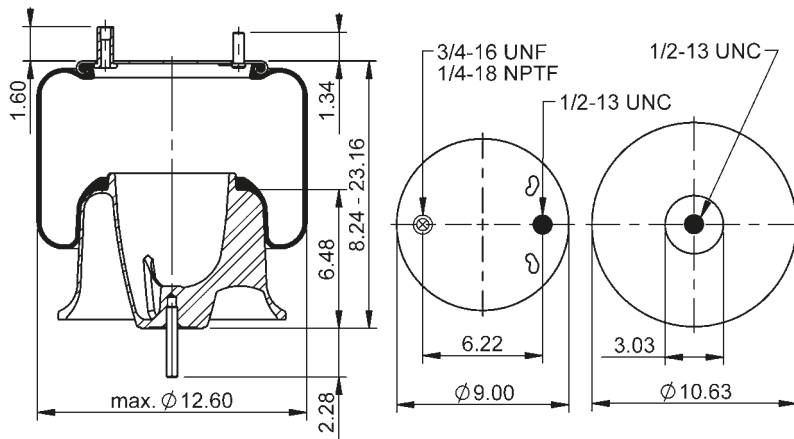

64266



**lb** 14.7 lb **No.** 9320166

**Cross-reference | Cruce de Referencia**  
Firestone W01-358-9781  
Goodyear 1R12-603

**Manufacturer | Fabricante**  
Freightliner  
A16-14004-000  
681-320-0017  
16-13810-000  
16-13840-000  
16-15595-000  
16-16773-000  
Volvo 85101151  
Loadguard and more SC2750

**1/4-18 NPTF:** max. 22 lb-ft  
**1/2-13 UNC:** max. 35 lb-ft  
**3/4-16 UNF:** max. 50 lb-ft



### 9 10S-16 P 382

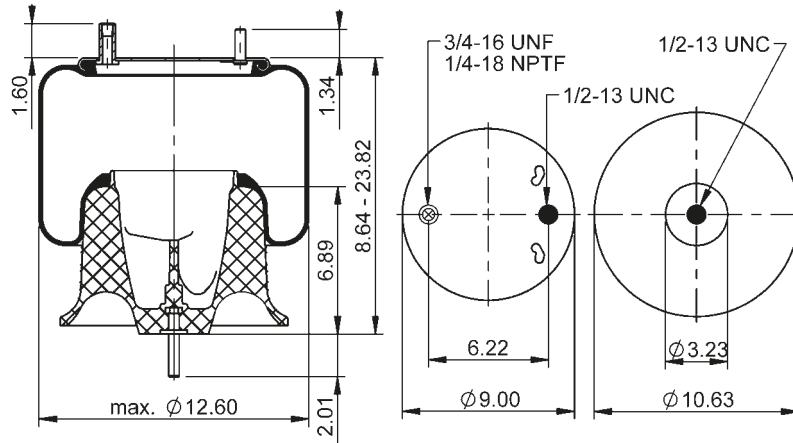

67473



**lb** 12.3 lb **No.** 9312314

**Cross-reference | Cruce de Referencia**

Firestone W01-358-9780  
Goodyear 1R12-303

**Manufacturer | Fabricante**

Freightliner 16-13810-000  
16-13810-001  
16-13810-002  
16-13840-000  
16-14377-000  
16-16825-000  
16-16773-000  
681-320-0017

and more

1/4-18 NPTF: max. 22 lb-ft  
1/2-13 UNC: max. 35 lb-ft  
3/4-16 UNF: max. 50 lb-ft

### 9 10S-16 S 382

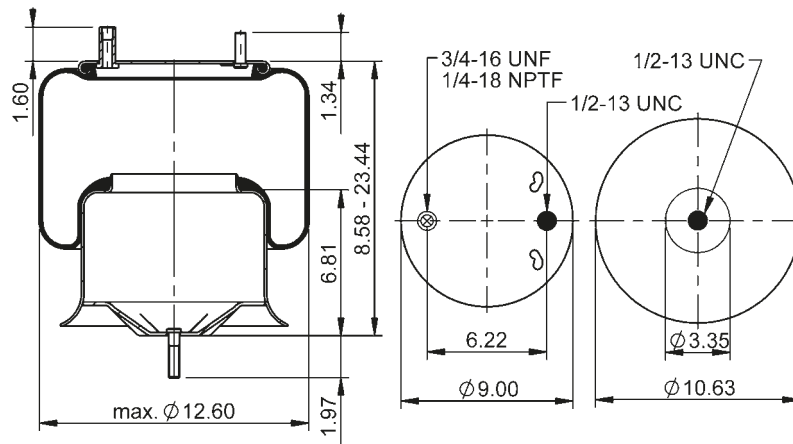

77614



**lb** 18.5 lb **No.** 9318823

**Cross-reference | Cruce de Referencia**

Firestone W01-358-9782

**Manufacturer | Fabricante**

Freightliner A16-14004-000  
681-320-0017  
16-13810-000  
16-13840-000  
16-15595-000  
16-16773-000  
Volvo 85101151  
Loadguard SC2750  
and more

1/2-13 UNC: max. 35 lb-ft  
3/4-16 UNF: max. 50 lb-ft

### 9 10S-16 A 999

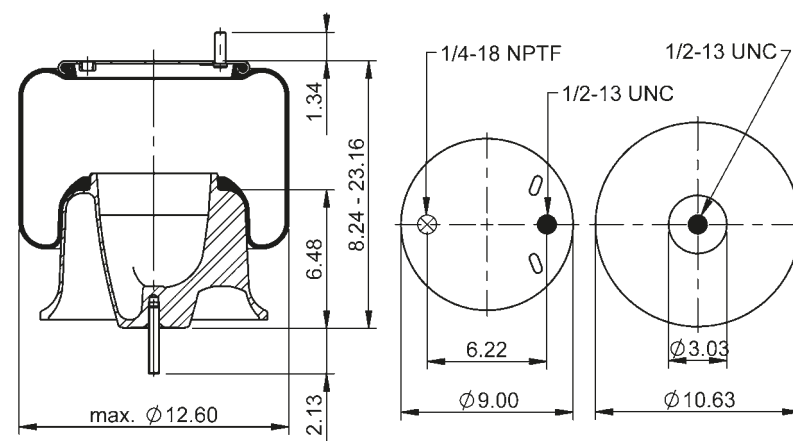

68207



**lb** 14.3 lb **No.** 9320166

**Manufacturer | Fabricante**

Freightliner A16-17574-000  
A16-19677-000  
A16-19677-001  
A16-17574-001  
A16-17574-002

1/4-18 NPTF: max. 22 lb-ft  
1/2-13 UNC: max. 35 lb-ft

### 9 10S-16 P 999

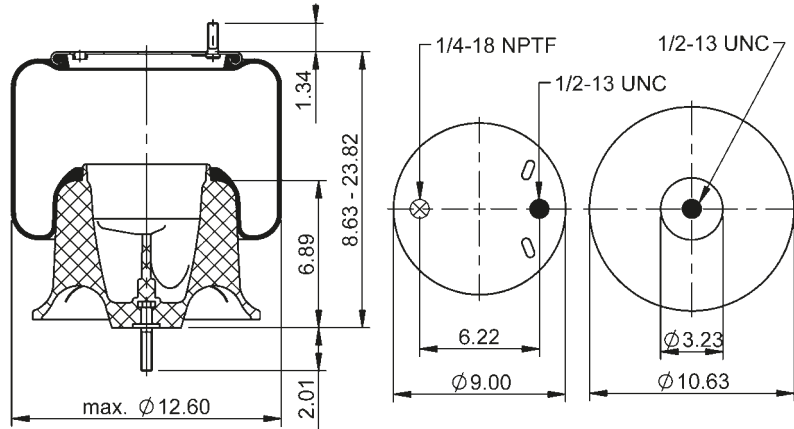

68208



**lb** 11.9 lb **No.** 9312314

**Cross-reference | Cruce de Referencia**  
 Firestone W01-377-9759

**Manufacturer | Fabricante**  
 Freightliner 16-19769-000  
 A16-18335-000  
 A16-18335-001

1/4-18 NPTF: max. 22 lb-ft  
 1/2-13 UNC: max. 35 lb-ft

### 910S-16P1068(BK)

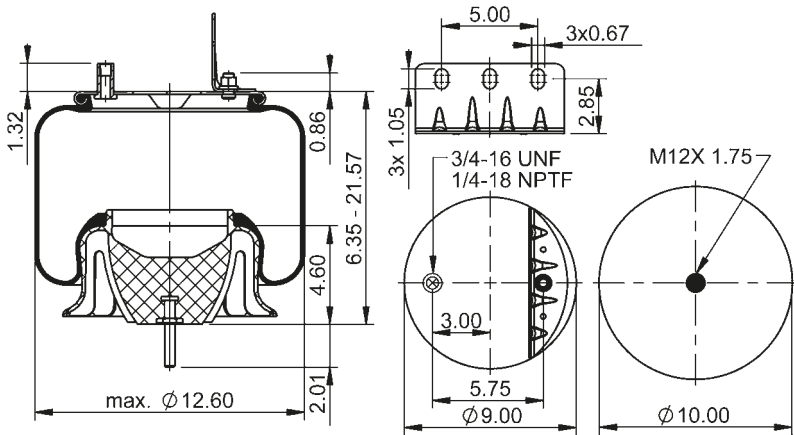

73770



**lb** 11.2 lb **No.** 9316239 910-18.5P456(BK)

**Cross-reference | Cruce de Referencia**  
 Firestone W01-358-9648  
 Goodyear 1R12-538

**Manufacturer | Fabricante**  
 Navistar/Fleetrite 2027911C1  
 2027911C2  
 2027911C3  
 1R12-1057

1/4-18 NPTF: max. 22 lb-ft  
 3/4-16 UNF: max. 50 lb-ft

### 9 10S-16 P 1600

**new**

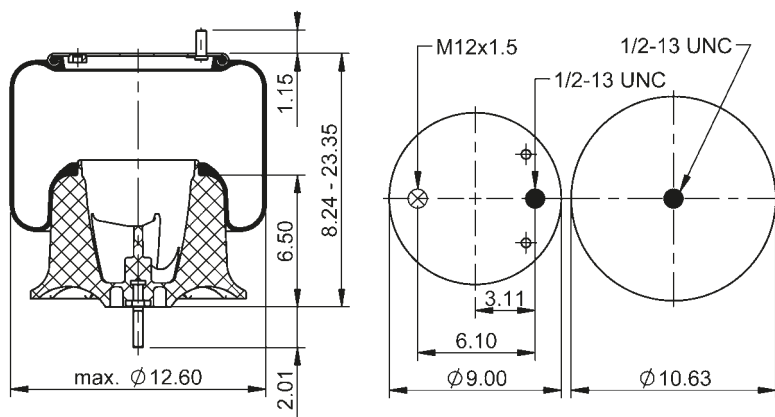

601538



**lb** 13.7 lb **No.** 9314025

**Manufacturer | Fabricante**  
 Freightliner A16-21557-000  
 A16-21557-001

1/2-13 UNC: max. 35 lb-ft  
 M12x1.5: max. 22 lb-ft

### 9 10S-16 P 1631

new

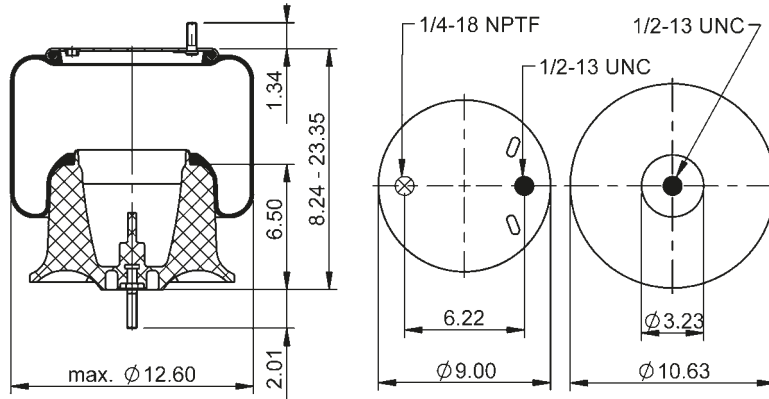

601986



**lb** 12.6 lb **No.** 9314025 **←** 78373

**Manufacturer | Fabricante**  
 Freightliner A16-20121-000  
 A16-20121-001

**1/4-18 NPTF:** max. 22 lb-ft  
**1/2-13 UNC:** max. 35 lb-ft

### 9 10S-16 A 1634

new

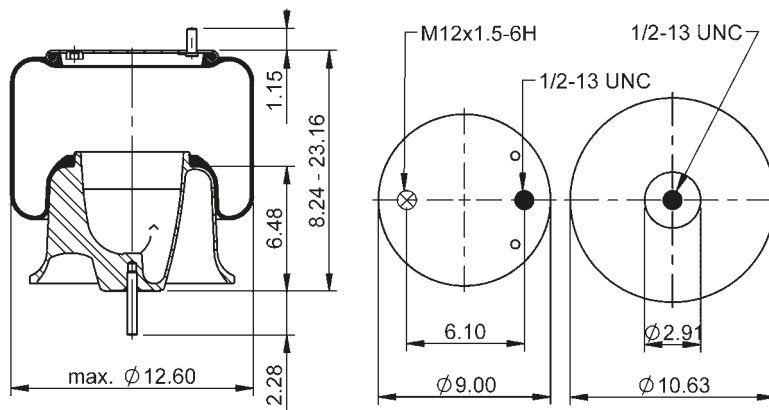

601989



**lb** 14.8 lb **No.** 9320166

**Manufacturer | Fabricante**  
 Freightliner A16-21556-000  
 A16-21556-001

**1/2-13 UNC:** max. 35 lb-ft  
**M12x1.5:** max. 22 lb-ft

### 9 10P-16.5 P 194

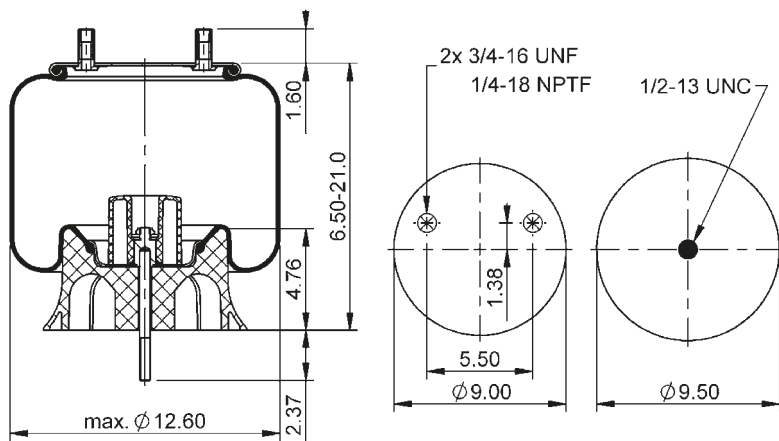

78226



**lb** 12.8 lb **No.** 9308128

**Manufacturer | Fabricante**  
 SAF Holland 90557403

**1/4-18 NPTF:** max. 22 lb-ft  
**1/2-13 UNC:** max. 35 lb-ft  
**3/4-16 UNF:** max. 50 lb-ft

### 9 10P-16.5 A 926

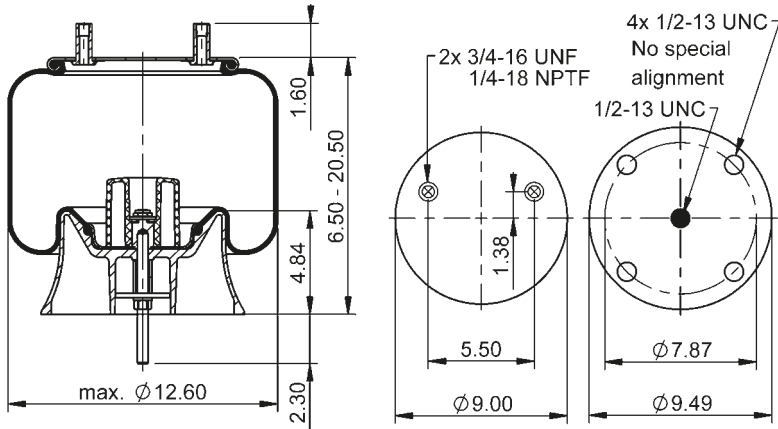

68155



**lb** 16.1 lb **No.** 9305281

**Manufacturer | Fabricante**  
SAF Holland 90557331  
90557373

**1/4-18 NPTF:** max. 22 lb-ft  
**1/2-13 UNC:** max. 35 lb-ft  
**3/4-16 UNF:** max. 50 lb-ft

### 9 10BS-17 P 1192 (BK)

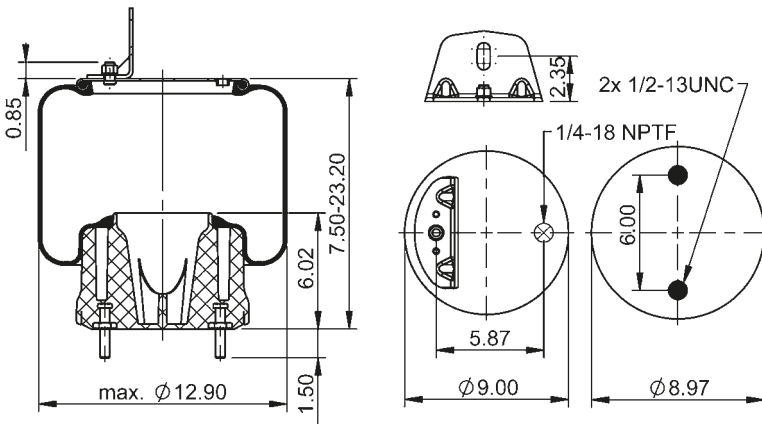

75266



**lb** 14.2 lb **No.** 9316995

**Cross-reference | Cruce de Referencia**  
Firestone W01-358-9865

**Manufacturer | Fabricante**  
Hendrickson 67043-002

**1/4-18 NPTF:** max. 22 lb-ft  
**1/2-13 UNC:** max. 35 lb-ft

### 9 10BS-17 P 1193

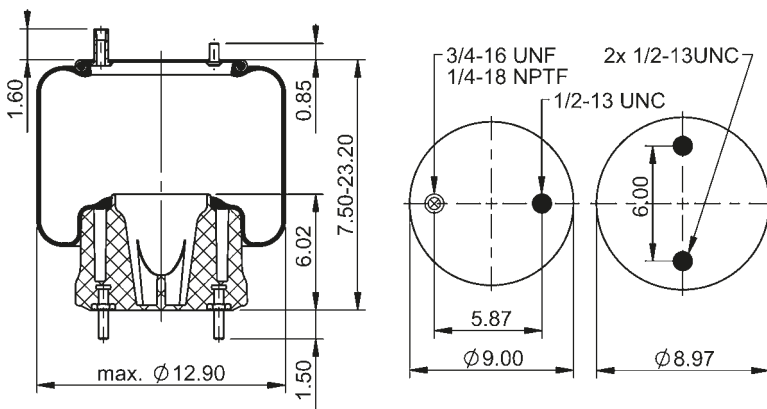

75267



**lb** 13.0 lb **No.** 9316995

**Cross-reference | Cruce de Referencia**  
Firestone W01-358-9866

**Manufacturer | Fabricante**  
Hendrickson 67391-2

**1/4-18 NPTF:** max. 22 lb-ft  
**1/2-13 UNC:** max. 35 lb-ft  
**3/4-16 UNF:** max. 50 lb-ft

### 9 10BS-17 P 1193 (BK)

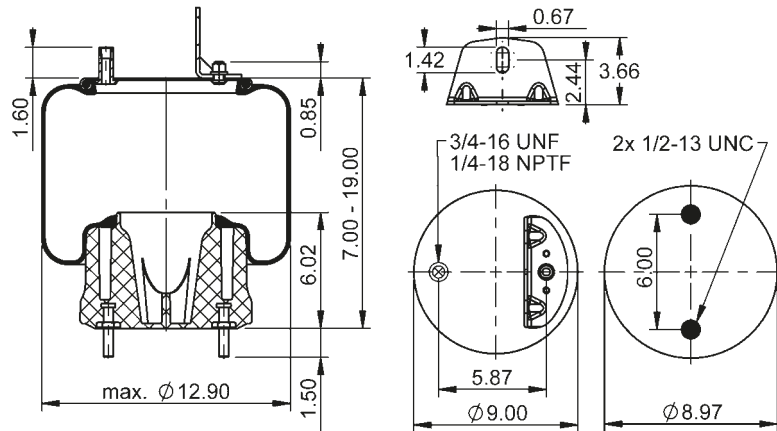

77593



**lb** 15.0 lb **No.** 9316995

**Cross-reference | Cruce de Referencia**  
Firestone W01-358-9867

**Manufacturer | Fabricante**  
Hendrickson 67392-2

1/4-18 NPTF: max. 22 lb-ft  
1/2-13 UNC: max. 35 lb-ft  
3/4-16 UNF: max. 50 lb-ft

### 9 10S-17 P 1152 (BK)

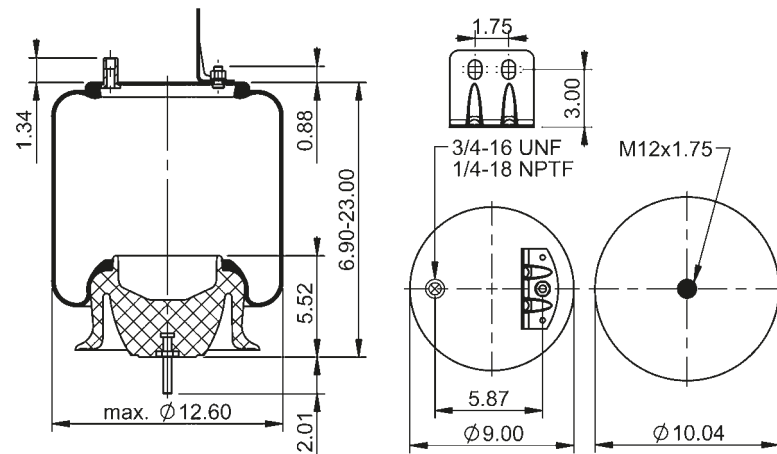

74882



**lb** 11.7 lb **No.** 9316239 9 10B-17.5 P 196

**Cross-reference | Cruce de Referencia**  
Goodyear 1R12-622

**Manufacturer | Fabricante**  
International 3596112C1  
Navistar/Fleetrite

1/4-18 NPTF: max. 22 lb-ft  
3/4-16 UNF: max. 50 lb-ft  
M12x1.75: max. 30 lb-ft

### 9 10S-17 P 1153 (BK)

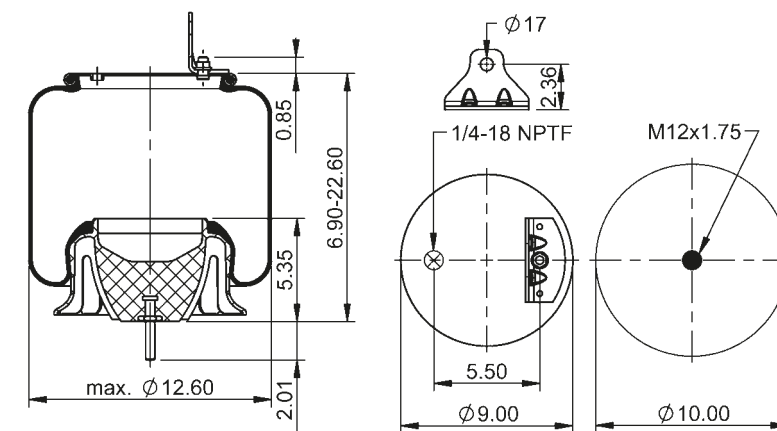

74883



**lb** 11.3 lb **No.** 9314556

**Cross-reference | Cruce de Referencia**  
Firestone W01-M58-8463  
Goodyear 1R12-629  
1R12-647

**Manufacturer | Fabricante**  
Mack 20910892  
57QL519M  
Volvo 20733034

1/4-18 NPTF: max. 22 lb-ft  
M12x1.75: max. 30 lb-ft

### 9 10S-17 P 1154 (BK)

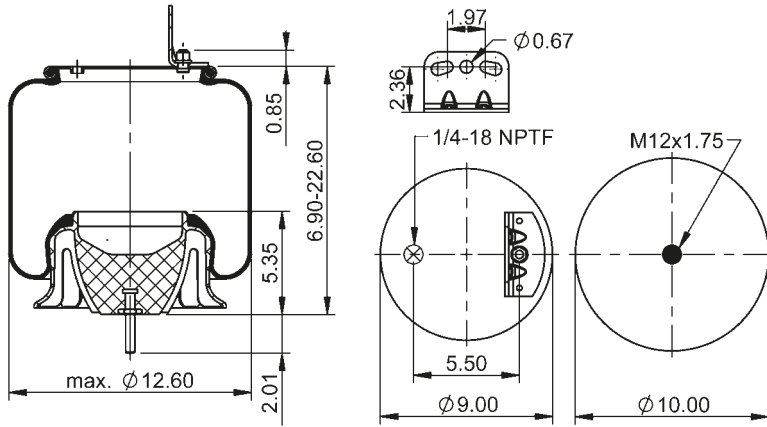

74884



**lb** 12.5 lb **No.** 9314556 **←** 9 10-17.5 P 449

**Cross-reference | Cruce de Referencia**

Firestone W01-358-8829  
Goodyear 1R12-615

**Manufacturer | Fabricante**

Mack 57QL54M  
3934699  
Volvo 8079902  
8084296  
8097092  
20396293  
20413888  
20505399

and more

**1/4-18 NPTF:** max. 22 lb-ft  
**M12x1.75:** max. 30 lb-ft

### 9 10S-17 P 1206

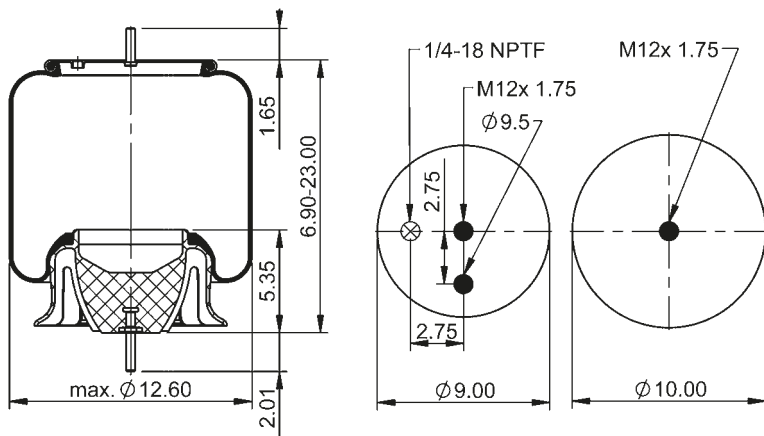

75561



**lb** 11.5 lb **No.** 9316239

**Cross-reference | Cruce de Referencia**

Firestone W01-M58-8468  
Goodyear 1R12-654  
1R12-1049

**Manufacturer | Fabricante**

Mack 21244322  
21669088  
Volvo 21132004  
21132005

**1/4-18 NPTF:** max. 22 lb-ft  
**M12x1.75:** max. 30 lb-ft

### 9 10-17.5 P 023

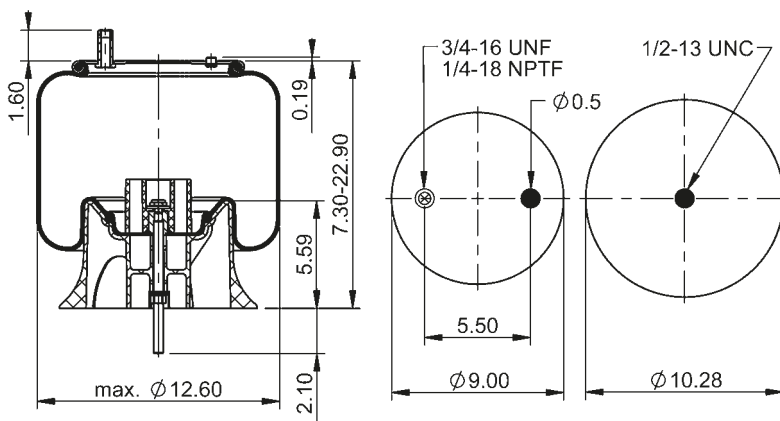

68158



**lb** 14.6 lb **No.** 9314552

**Cross-reference | Cruce de Referencia**

Firestone W01-358-9972

**Manufacturer | Fabricante**

SAF Holland 90557302

**1/4-18 NPTF:** max. 22 lb-ft  
**1/2-13 UNC:** max. 35 lb-ft  
**3/4-16 UNF:** max. 50 lb-ft

### 9 10-17.5 P 136 (BK)

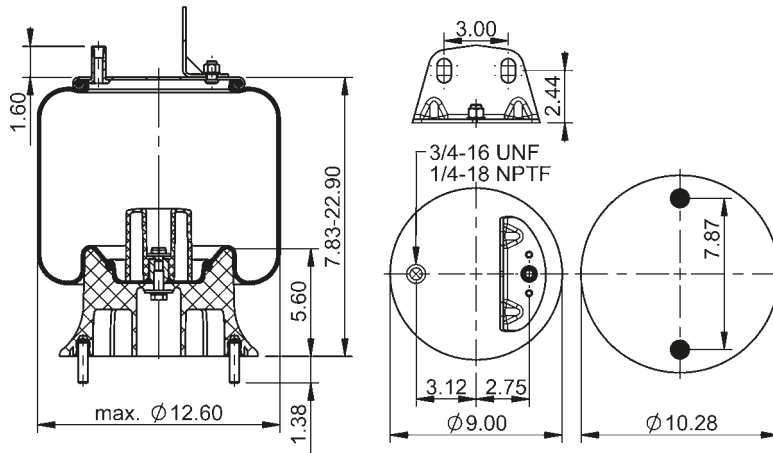

78015



**lb** 15.7 lb **No.** 9308133

**Manufacturer | Fabricante**  
SAF Holland 90557407

**Wrench** 1/4-18 NPTF: max. 22 lb-ft  
1/2-13 UNC: max. 35 lb-ft  
3/4-16 UNF: max. 50 lb-ft

### 9 10-17.5 P 169

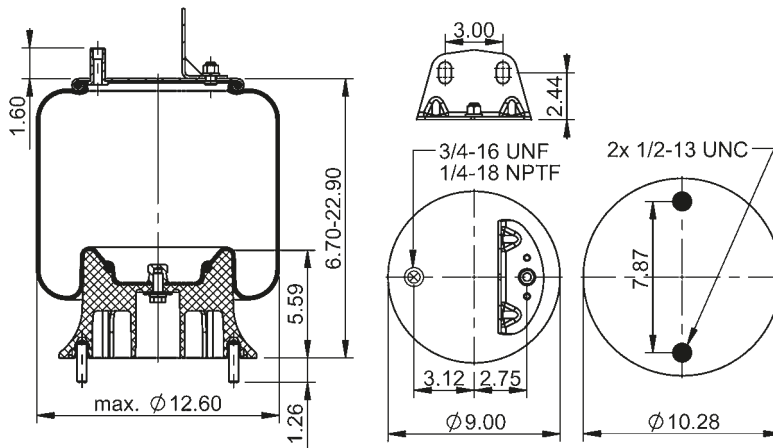

74205



**lb** 14.8 lb **No.** 9308133

**Manufacturer | Fabricante**  
SAF Holland 90557393

**Wrench** 1/8-27 NPTF: max. 18 lb-ft  
1/2-13 UNC: max. 35 lb-ft  
3/4-16 UNF: max. 5 lb-ft

### 9 10-17.5 P 173

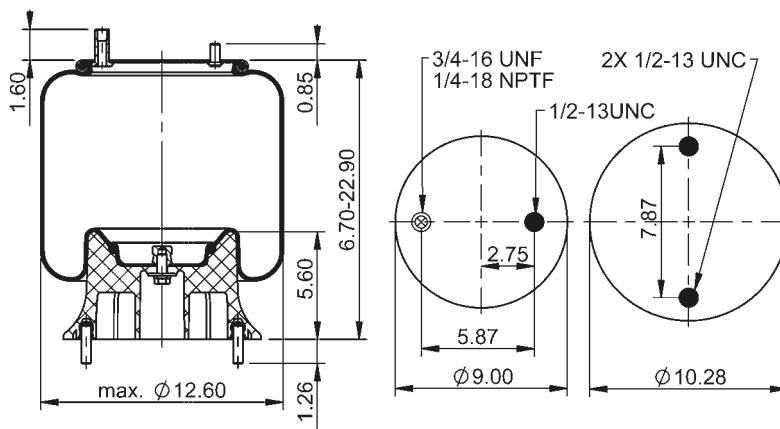

78181



**lb** 13.7 lb **No.** 9308133

**Manufacturer | Fabricante**  
SAF Holland 90557395

**Wrench** 1/4-18 NPTF: max. 22 lb-ft  
1/2-13 UNC: max. 35 lb-ft  
3/4-16 UNF: max. 50 lb-ft

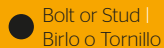

Bolt or Stud | Birlo o Tornillo



Hole | Tuerca Ciega



Combination Stud | Combinación de Entrada de Aire y Birlo



Air Inlet | Entrada de Aire



Stud and Nut | Birlo y Tuerca

### 9 10-17.5 P 175

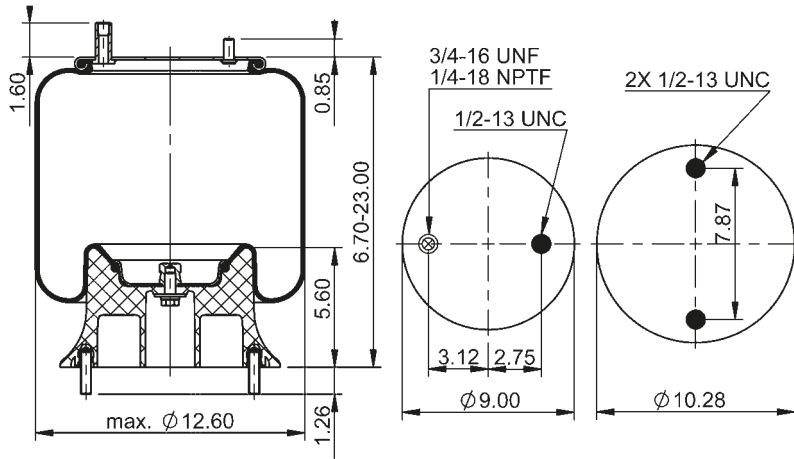

78220



**lb** 12.8 lb **No.** 9308133

**Manufacturer | Fabricante**  
SAF Holland 90557396

**1/4-18 NPTF:** max. 22 lb-ft  
**1/2-13 UNC:** max. 35 lb-ft  
**3/4-16 UNF:** max. 50 lb-ft

### 9 10-17.5 P 418

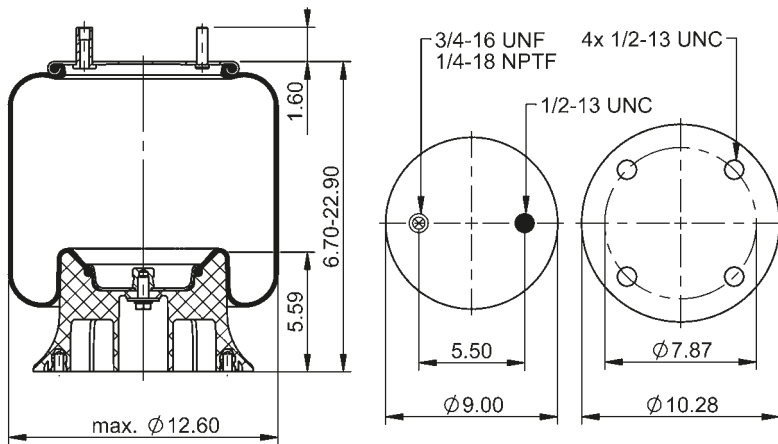

64334



**lb** 13.2 lb **No.** 9308133

**Cross-reference | Cruce de Referencia**  
Firestone W01-358-9342  
Goodyear 1R12-450

**Manufacturer | Fabricante**  
Granning 2727

**1/4-18 NPTF:** max. 22 lb-ft  
**1/2-13 UNC:** max. 35 lb-ft  
**3/4-16 UNF:** max. 50 lb-ft

### 9 10-17.5 P 426

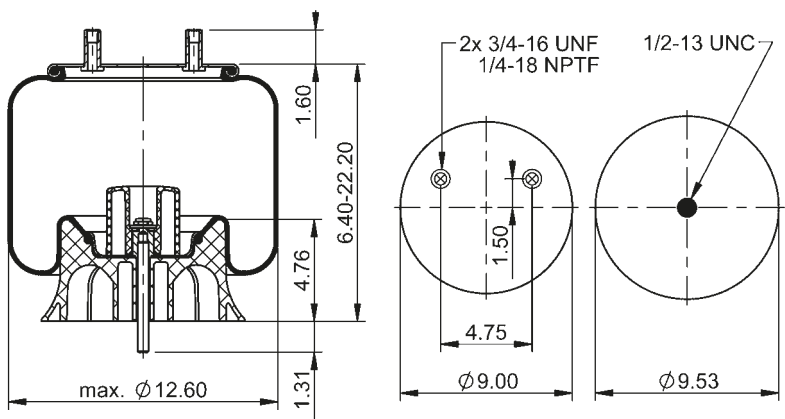

64398



**lb** 13.1 lb **No.** 9308128

**Cross-reference | Cruce de Referencia**  
Firestone W01-358-9902  
Goodyear 1R12-640

**Manufacturer | Fabricante**  
SAF Holland 90557138

**1/4-18 NPTF:** max. 22 lb-ft  
**1/2-13 UNC:** max. 35 lb-ft  
**3/4-16 UNF:** max. 50 lb-ft



### 9 10-17.5 P 428

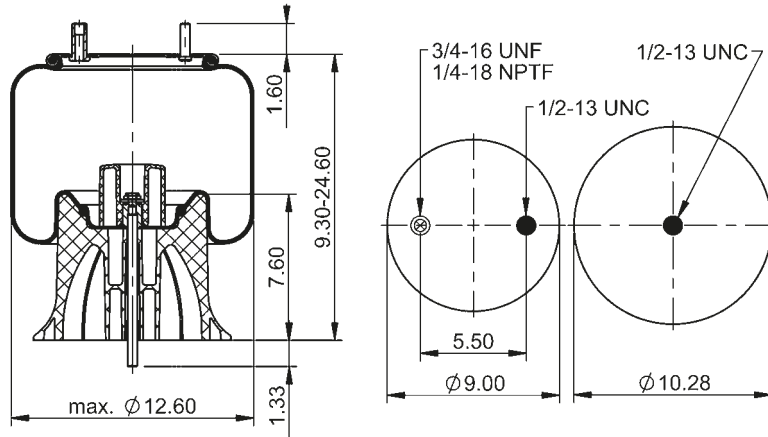

64399



**lb** 15.3 lb **No.** 9306248

**Cross-reference | Cruce de Referencia**  
 Firestone W01-358-9922  
 Goodyear 1R12-498

**Manufacturer | Fabricante**  
 SAF Holland 90557119

1/4-18 NPTF: max. 22 lb-ft  
 1/2-13 UNC: max. 35 lb-ft  
 3/4-16 UNF: max. 50 lb-ft

### 9 10-17.5 P 429

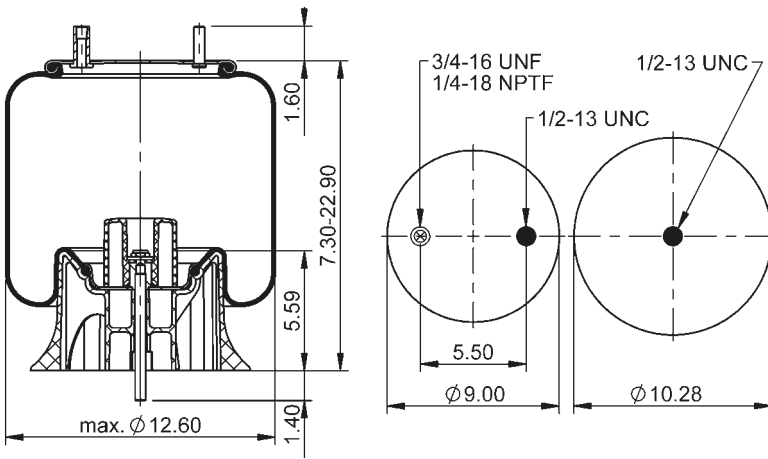

64278



**lb** 13.4 lb **No.** 9314552

**Cross-reference | Cruce de Referencia**  
 Firestone W01-358-9923  
 Goodyear 1R12-481

**Manufacturer | Fabricante**  
 Brake & Wheel M3548  
 SAF Holland 90557118

1/4-18 NPTF: max. 22 lb-ft  
 1/2-13 UNC: max. 35 lb-ft  
 3/4-16 UNF: max. 50 lb-ft

### 9 10-17.5 P 430

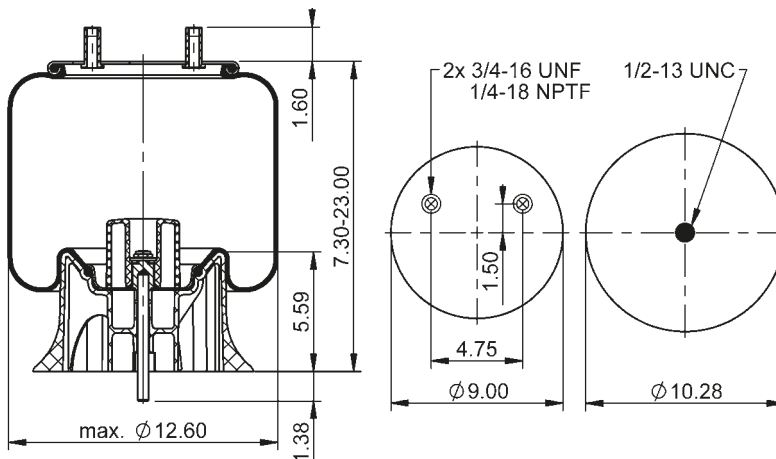

64400



**lb** 13.4 lb **No.** 9308132

**Cross-reference | Cruce de Referencia**  
 Firestone W01-358-9942

**Manufacturer | Fabricante**  
 SAF Holland 90557142

1/4-18 NPTF: max. 22 lb-ft  
 1/2-13 UNC: max. 35 lb-ft  
 3/4-16 UNF: max. 50 lb-ft

### 9 10-17.5 P 436

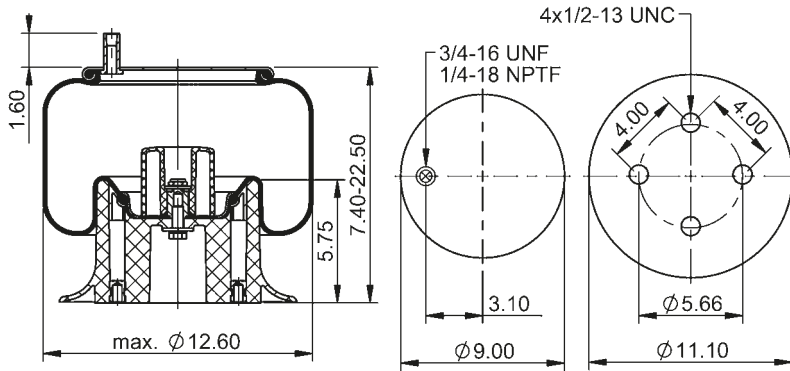

64401



**lb** 14.0 lb **No.** 9308998

**Cross-reference | Cruce de Referencia**

Firestone	W01-358-8944
	W01-358-9015
Goodyear	1R12-366

**Manufacturer | Fabricante**

Hendrickson	S-20217
Loadguard	SC2756

- 1/4-18 NPTF: max. 22 lb-ft
- 1/2-13 UNC: max. 35 lb-ft
- 3/4-16 UNF: max. 50 lb-ft

### 9 10-17.5 P 443

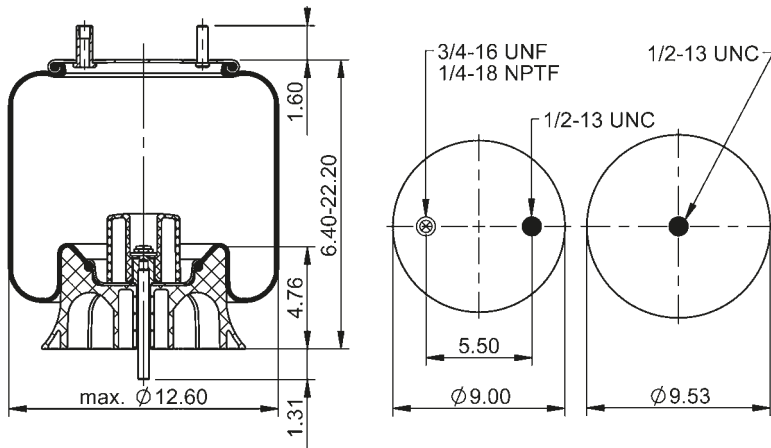

64402



**lb** 13.0 lb **No.** 9308128

**Cross-reference | Cruce de Referencia**

Firestone	W01-358-9921
Goodyear	1R12-502

**Manufacturer | Fabricante**

SAF Holland	90557117
Watson & Chalin	AS-0090

- 1/4-18 NPTF: max. 22 lb-ft
- 1/2-13 UNC: max. 35 lb-ft
- 3/4-16 UNF: max. 50 lb-ft

### 9 10-17.5 P 445 (BK)

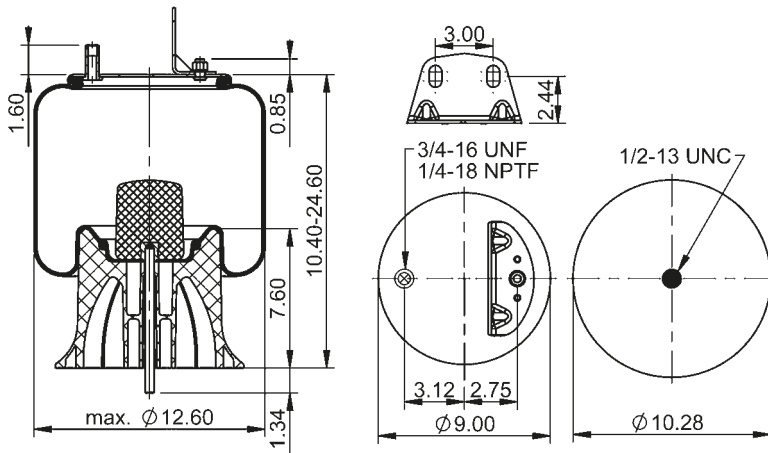

69650



**lb** 16.2 lb **No.** 9306248

**Cross-reference | Cruce de Referencia**

Firestone	W01-358-9473
Goodyear	1R12-586

**Manufacturer | Fabricante**

SAF Holland	90557152
	90557179
	90557215

- 1/4-18 NPTF: max. 22 lb-ft
- 1/2-13 UNC: max. 35 lb-ft
- 3/4-16 UNF: max. 50 lb-ft

### 9 10-17.5 P 452

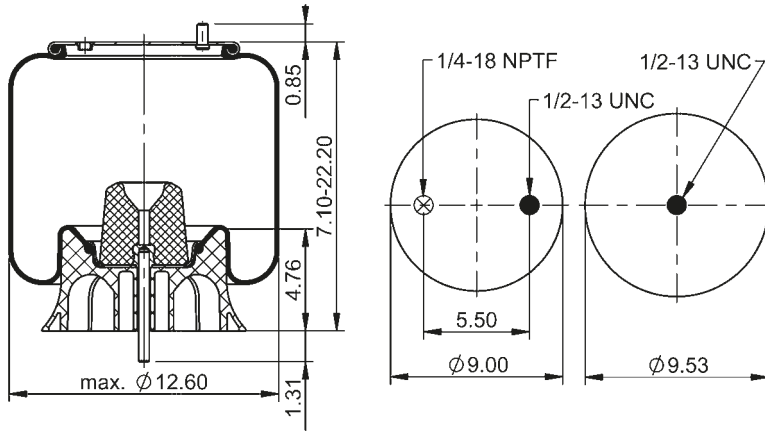

64404



**lb** 14.1 lb **No.** 9308128

**Cross-reference | Cruce de Referencia**  
Firestone W01-358-9947

**Manufacturer | Fabricante**  
Reyco 20142-01  
20142-01K

1/4-18 NPTF: max. 22 lb-ft  
1/2-13 UNC: max. 35 lb-ft

### 9 10-17.5 P 454

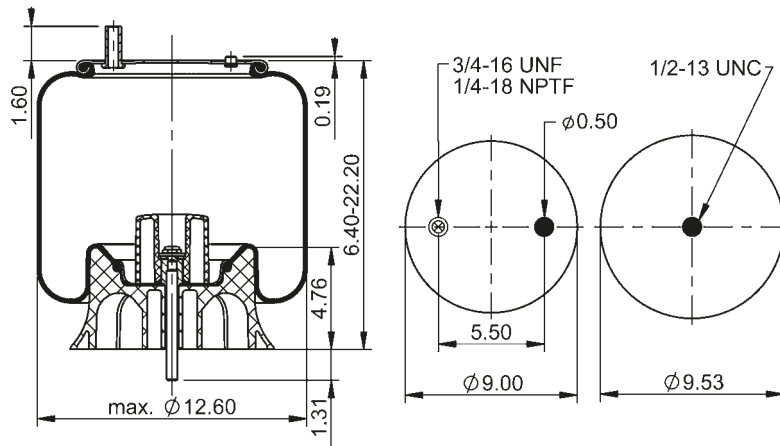

64405



**lb** 13.0 lb **No.** 9308128

**Cross-reference | Cruce de Referencia**  
Firestone W01-358-9936  
Goodyear 1R12-499

**Manufacturer | Fabricante**  
SAF Holland 90557156  
90557300

1/4-18 NPTF: max. 22 lb-ft  
1/2-13 UNC: max. 35 lb-ft  
3/4-16 UNF: max. 50 lb-ft

### 9 10-17.5 P 467 (BK)

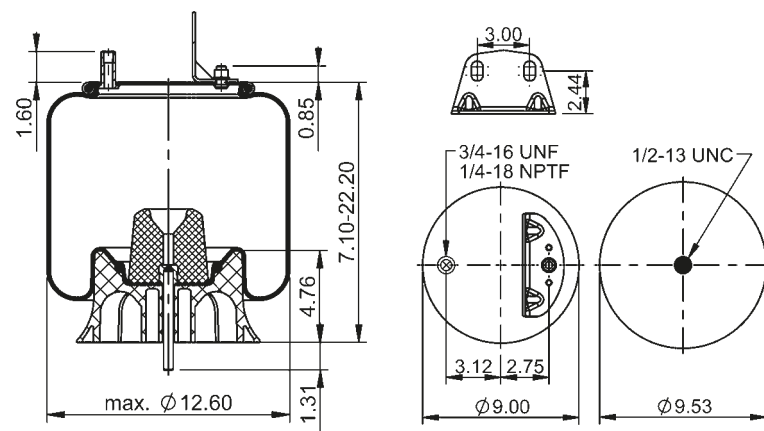

69649



**lb** 14.2 lb **No.** 9308128

**Cross-reference | Cruce de Referencia**  
Firestone W01-358-9472

**Manufacturer | Fabricante**  
Navistar/Fleetrite 2027297C1  
SAF Holland 90557147  
90557178  
90557181

1/4-18 NPTF: max. 22 lb-ft  
1/2-13 UNC: max. 35 lb-ft  
3/4-16 UNF: max. 50 lb-ft

### 9 10-17.5 P 475

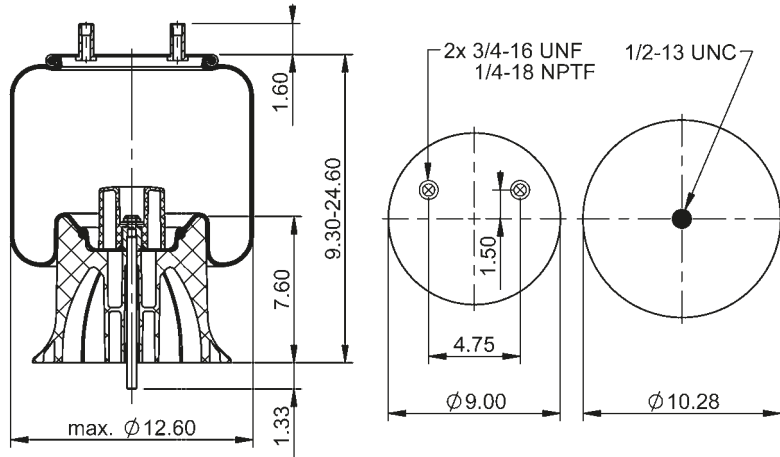

64407



**lb** 15.3 lb **No.** 9306248

**Cross-reference | Cruce de Referencia**  
Firestone W01-358-9943

**Manufacturer | Fabricante**  
SAF Holland 90557143

**1/4-18 NPTF:** max. 22 lb-ft  
**1/2-13 UNC:** max. 35 lb-ft  
**3/4-16 UNF:** max. 50 lb-ft

### 9 10-17.5 P 501 (BK)

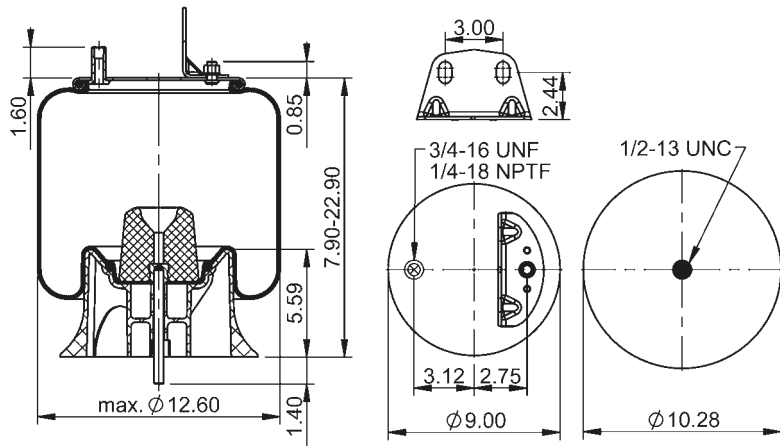

69647



**lb** 14.5 lb **No.** 9314552

**Cross-reference | Cruce de Referencia**  
Firestone W01-358-9470

**Manufacturer | Fabricante**  
SAF Holland 90557145  
90557211

**1/4-18 NPTF:** max. 22 lb-ft  
**1/2-13 UNC:** max. 35 lb-ft  
**3/4-16 UNF:** max. 50 lb-ft

### 9 10-17.5 P 502 (BK)

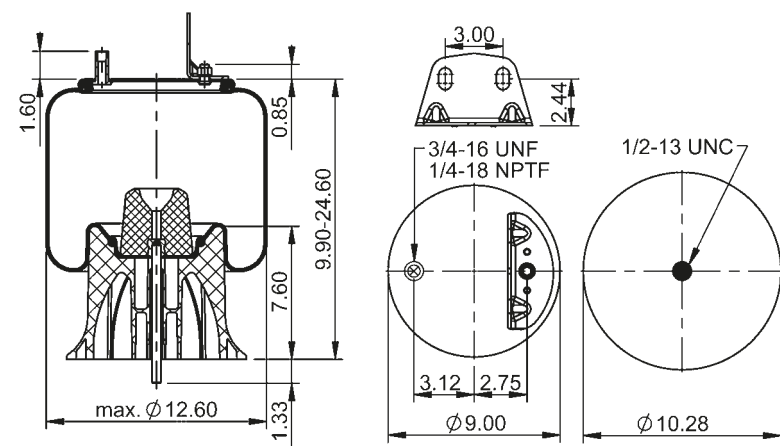

69648



**lb** 16.5 lb **No.** 9306248

**Cross-reference | Cruce de Referencia**  
Firestone W01-358-9471  
Goodyear 1R12-504

**Manufacturer | Fabricante**  
SAF Holland 90557146  
90557177  
90557182  
AS-0170

**1/4-18 NPTF:** max. 22 lb-ft  
**1/2-13 UNC:** max. 35 lb-ft  
**3/4-16 UNF:** max. 50 lb-ft

### 9 10-17.5 A 535

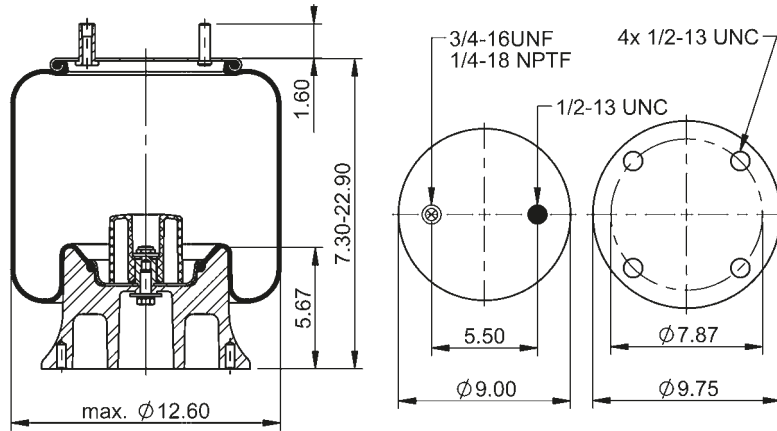

64411



**lb** 16.0 lb **No.** 9311400

**Cross-reference | Cruce de Referencia**  
Firestone W01-358-9948

**Manufacturer | Fabricante**  
SAF Holland 90557227

1/4-18 NPTF: max. 22 lb-ft  
1/2-13 UNC: max. 35 lb-ft  
3/4-16 UNF: max. 50 lb-ft

### 9 10-17.5 P 536

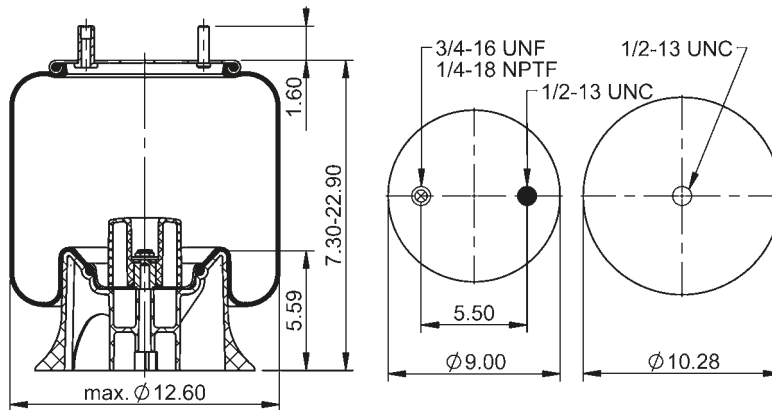

64423



**lb** 13.1 lb **No.** 9314552

**Cross-reference | Cruce de Referencia**  
Firestone W01-358-8903  
Goodyear 1R11-252

**Manufacturer | Fabricante**  
SAF Holland 90557169

1/4-18 NPTF: max. 22 lb-ft  
1/2-13 UNC: max. 35 lb-ft  
3/4-16 UNF: max. 50 lb-ft

### 9 10-17.5 P 548

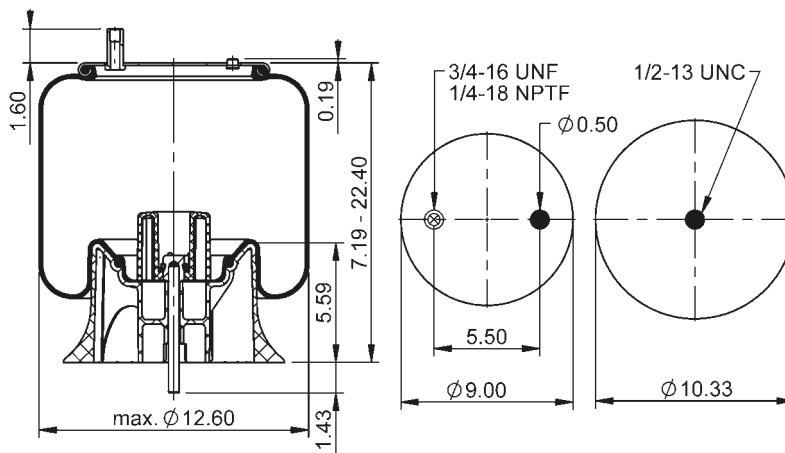

64412



**lb** 13.3 lb **No.** 9314552

**Cross-reference | Cruce de Referencia**  
Firestone W01-358-9935  
Goodyear 1R12-532

**Manufacturer | Fabricante**  
SAF Holland 90557157  
90557301  
Watson & Chalin AS-0164-1G

1/4-18 NPTF: max. 22 lb-ft  
1/2-13 UNC: max. 35 lb-ft  
3/4-16 UNF: max. 50 lb-ft

### 9 10-17.5 P 571

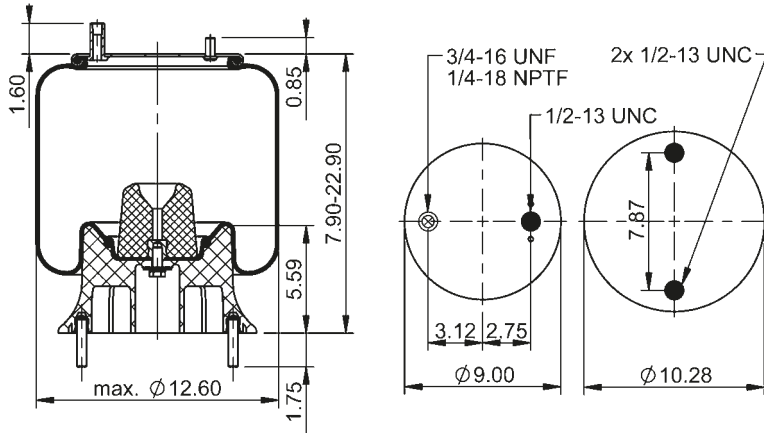

64415



**lb** 15.6 lb **No.** 9308133

**Cross-reference | Cruce de Referencia**

Firestone W01-358-9502  
Goodyear 1R12-554

**Manufacturer | Fabricante**

SAF Holland 90557211  
90557358

- 1/4-18 NPTF: max. 22 lb-ft
- 1/2-13 UNC: max. 35 lb-ft
- 3/4-16 UNF: max. 50 lb-ft

### 9 10-17.5 P 572 (BK)

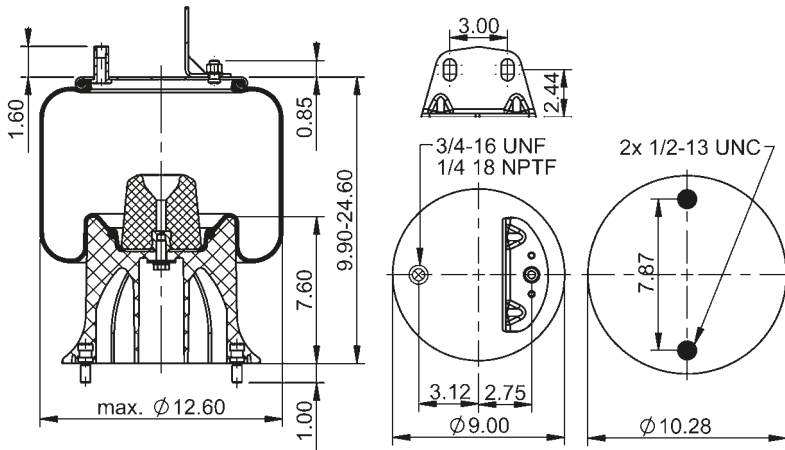

69662



**lb** 15.9 lb **No.** 9308244

**Cross-reference | Cruce de Referencia**

Firestone W01-358-9501  
Goodyear 1R12-552  
1R12-485

**Manufacturer | Fabricante**

SAF Holland 90557212  
90557214

- 1/4-18 NPTF: max. 22 lb-ft
- 1/2-13 UNC: max. 35 lb-ft
- 3/4-16 UNF: max. 50 lb-ft

### 9 10-17.5 P 573 (BK)

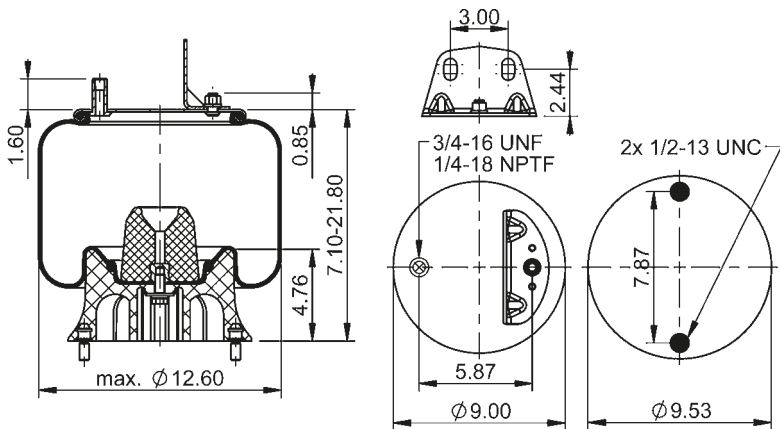

70335



**lb** 15.6 lb **No.** 9308245 64417

**Manufacturer | Fabricante**

SAF Holland 90557213

- 1/8-27 NPTF: max. 22 lb-ft
- 1/2-13 UNC: max. 35 lb-ft
- 3/4-16 UNF: max. 50 lb-ft

### 9 10-17.5 P 574 (BK)

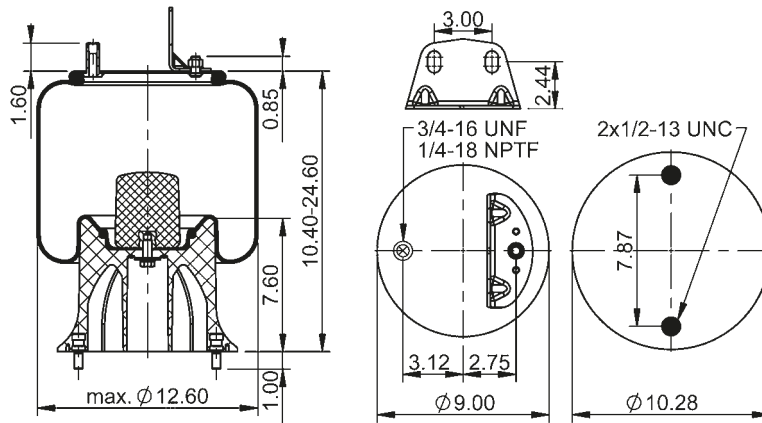

69654



**lb** 15.5 lb **No.** 9308244

**Cross-reference | Cruce de Referencia**

Firestone	W01-358-9504
Goodyear	1R12-484
	1R12-486

**Manufacturer | Fabricante**

SAF Holland 90557216

1/4-18 NPTF: max. 22 lb-ft  
 1/2-13 UNC: max. 35 lb-ft  
 3/4-16 UNF: max. 50 lb-ft

### 9 10-17.5 P 731 (BK)

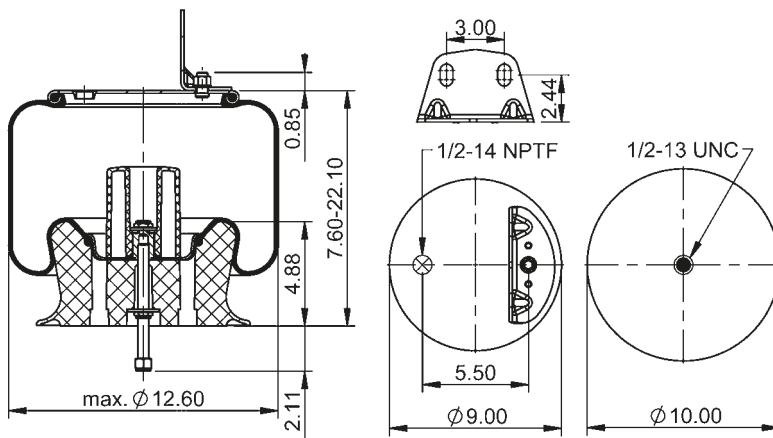

64668



**lb** 16.3 lb **No.** 9308660

**Cross-reference | Cruce de Referencia**

Firestone	W01-358-9966
-----------	--------------

**Manufacturer | Fabricante**

Reyco 20124-01  
 20124-01A  
 20124-01K  
 20124-02  
 20124-12

1/2-13 UNC: max. 35 lb-ft  
 1/2-14 NPTF: max. 22 lb-ft

### 9 10-17.5 P 732 (BK)

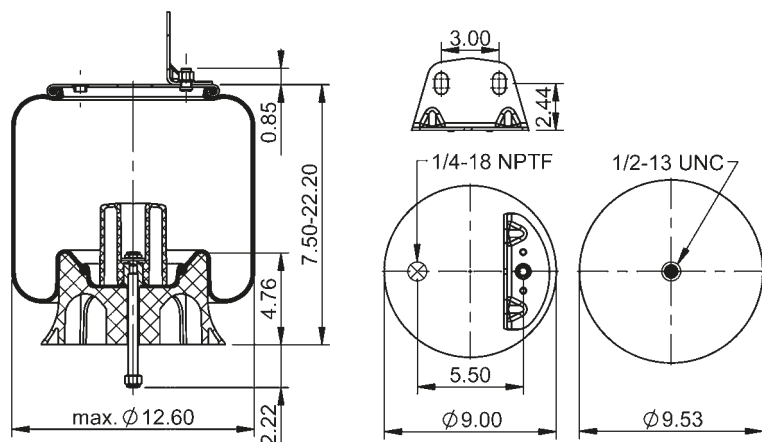

64669



**lb** 14.7 lb **No.** 9308128

**Cross-reference | Cruce de Referencia**

Firestone	W01-358-9947
-----------	--------------

**Manufacturer | Fabricante**

Reyco 20142-01  
 20142-01K

1/4-18 NPTF: max. 22 lb-ft  
 1/2-13 UNC: max. 35 lb-ft

### 9 10-17.5 P 733

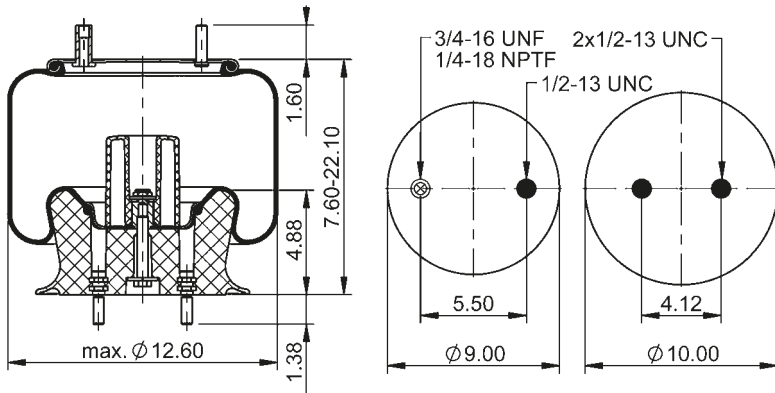

64670



**lb** 14.9 lb **No.** 9308663

**Manufacturer | Fabricante**

Reyco 12884-01

- 1/4-18 NPTF: max. 22 lb-ft
- 1/2-13 UNC: max. 35 lb-ft
- 3/4-16 UNF: max. 50 lb-ft

### 9 10-17.5 P 779

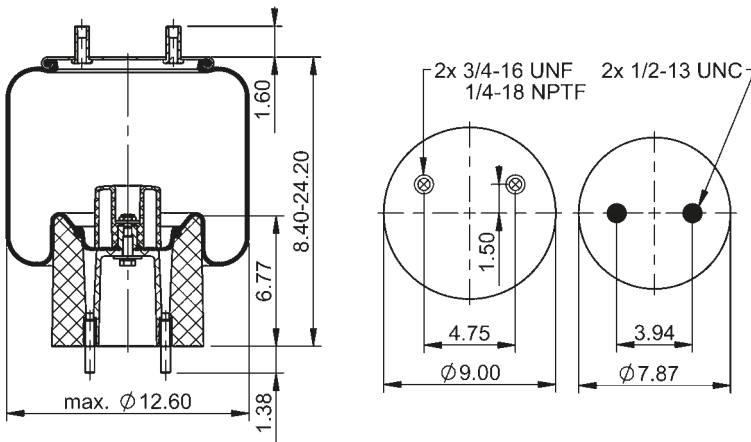

64729



**lb** 14.0 lb **No.** 9306128

**Cross-reference | Cruce de Referencia**

Firestone W01-358-6258

**Manufacturer | Fabricante**

Meritor 21227892  
SAF Holland 90036258

- 1/4-18 NPTF: max. 22 lb-ft
- 1/2-13 UNC: max. 35 lb-ft
- 3/4-16 UNF: max. 50 lb-ft

### 9 10-17.5 P 793

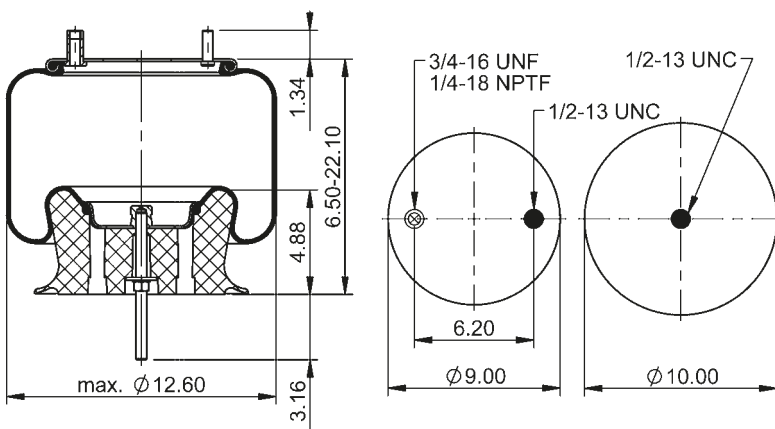

64756



**lb** 13.4 lb **No.** 9308660

**Manufacturer | Fabricante**

Link 1103-0509

- 1/4-18 NPTF: max. 22 lb-ft
- 1/2-13 UNC: max. 35 lb-ft
- 3/4-16 UNF: max. 50 lb-ft



### 9 10-17.5 A 802

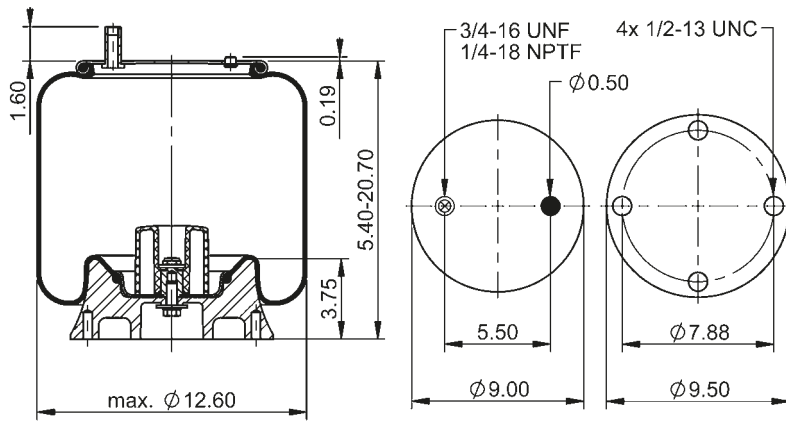

64762



**lb** 15.9 lb **No.** 9309183

**Cross-reference | Cruce de Referencia**

Firestone W01-358-1096  
Goodyear 1R12-494

**Manufacturer | Fabricante**

Cush C-0079

1/4-18 NPTF: max. 22 lb-ft  
1/2-13 UNC: max. 35 lb-ft  
3/4-16 UNF: max. 50 lb-ft

### 9 10-17.5 P 807 (BK)

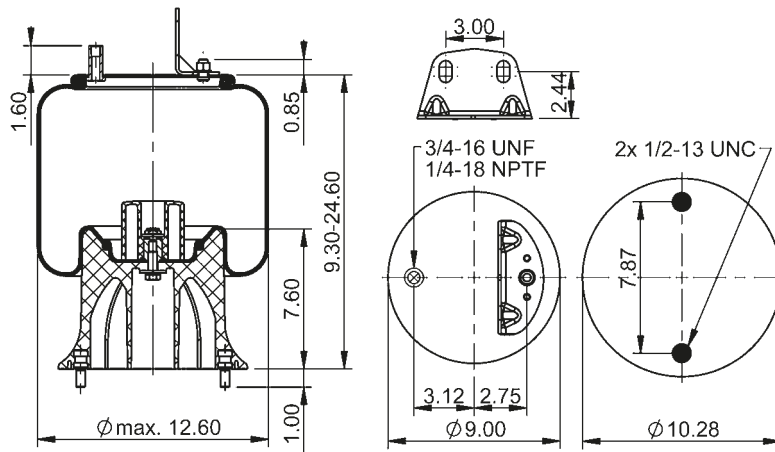

64767



**lb** 16.5 lb **No.** 9308244

**Manufacturer | Fabricante**

SAF Holland 90557316

1/4-18 NPTF: max. 22 lb-ft  
1/2-13 UNC: max. 35 lb-ft  
3/4-16 UNF: max. 50 lb-ft

### 9 10-17.5 P 831

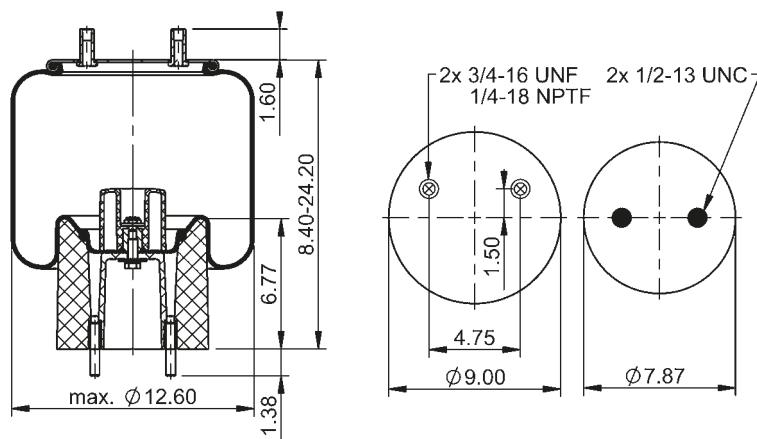

65831



**lb** 14.0 lb **No.** 9306128

**Cross-reference | Cruce de Referencia**

Firestone W01-358-6262

**Manufacturer | Fabricante**

Meritor 21227742

1/4-18 NPTF: max. 22 lb-ft  
1/2-13 UNC: max. 35 lb-ft  
3/4-16 UNF: max. 50 lb-ft

### 9 10-17.5 P 892 (BK)

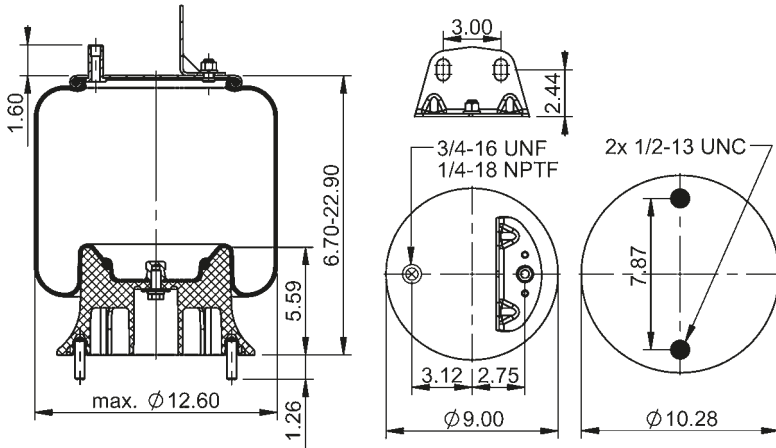

78179



**lb** 15.0 lb **No.** 9308133

**Manufacturer | Fabricante**  
SAF Holland 90557368

**1/4-18 NPTF:** max. 22 lb-ft  
**1/2-13 UNC:** max. 35 lb-ft  
**3/4-16 UNF:** max. 50 lb-ft

### 9 10-17.5 P 904

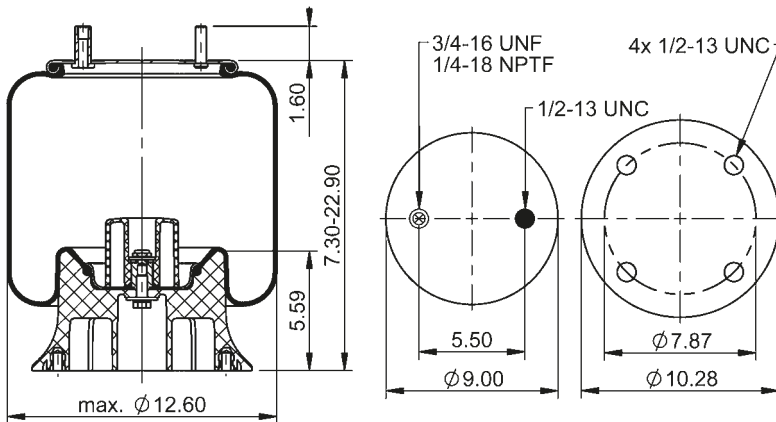

66700



**lb** 14.0 lb **No.** 9308133

**Cross-reference | Cruce de Referencia**  
Firestone W01-358-8888

**Manufacturer | Fabricante**  
Rowe Truck 0027ASC2500  
ASCT2500

**1/4-18 NPTF:** max. 22 lb-ft  
**1/2-13 UNC:** max. 35 lb-ft  
**3/4-16 UNF:** max. 50 lb-ft

### 9 10-17.5 A 930

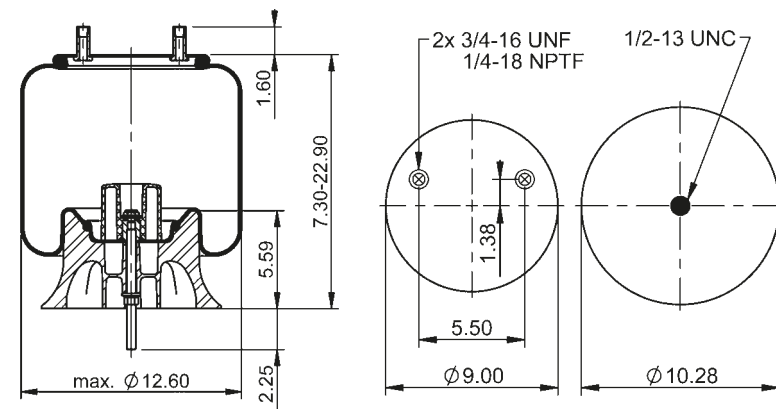

67586



**lb** 16.5 lb **No.** 9313361

**Cross-reference | Cruce de Referencia**  
Firestone W01-358-9974  
Goodyear 1R12-1048

**Manufacturer | Fabricante**  
SAF Holland 90557332

**1/4-18 NPTF:** max. 22 lb-ft  
**1/2-13 UNC:** max. 35 lb-ft  
**3/4-16 UNF:** max. 50 lb-ft

### 9 10-17.5 P 1056

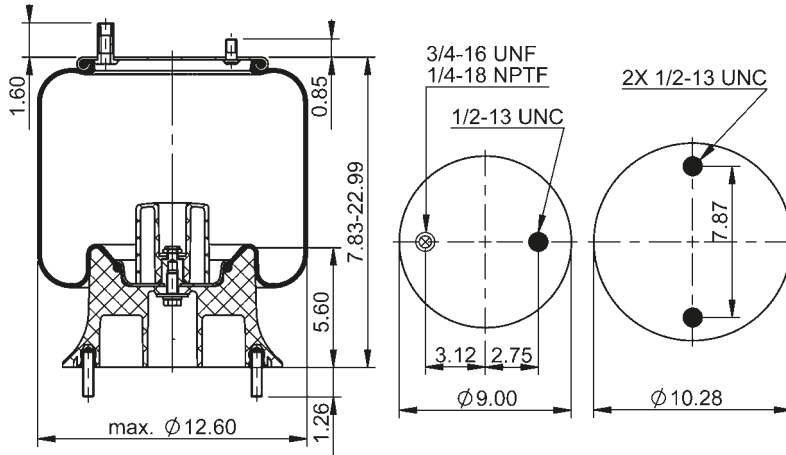

78221



**lb** 13.9 lb **No.** 9308133

**Manufacturer | Fabricante**  
SAF Holland 90557425

**1/4-18 NPTF:** max. 22 lb-ft  
**1/2-13 UNC:** max. 35 lb-ft  
**3/4-16 UNF:** max. 50 lb-ft

### 9 10-17.5 A 1205

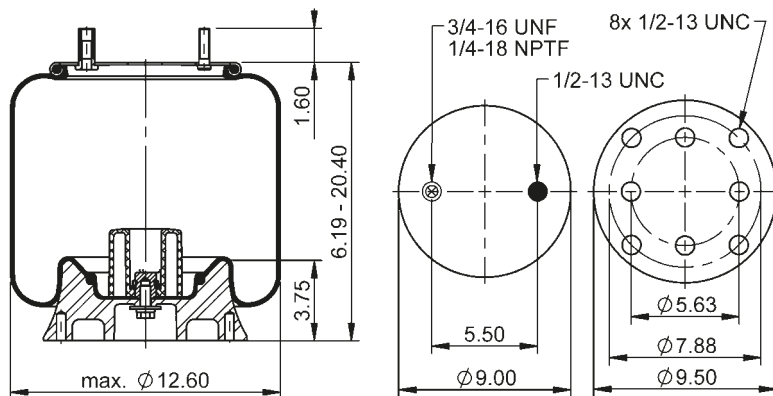

75562



**lb** 15.8 lb **No.** 9309183

**Cross-reference | Cruce de Referencia**  
Goodyear 1R12-617

**1/4-18 NPTF:** max. 22 lb-ft  
**1/2-13 UNC:** max. 35 lb-ft  
**3/4-16 UNF:** max. 50 lb-ft

### 9 10-17.5 P 1388

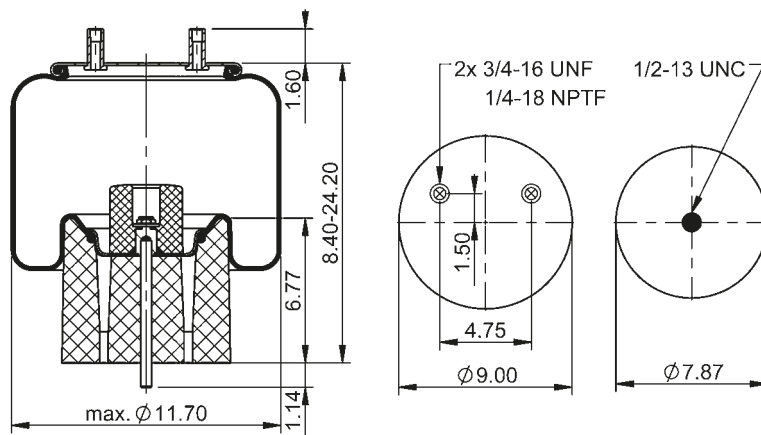

78601



**lb** 14.1 lb **No.** 9308765

**Cross-reference | Cruce de Referencia**  
Firestone W01-358-6231

**Manufacturer | Fabricante**  
Meritor 21227742

**1/4-18 NPTF:** max. 22 lb-ft  
**1/2-13 UNC:** max. 35 lb-ft  
**3/4-16 UNF:** max. 50 lb-ft

### 9 10B-17.5 A 323

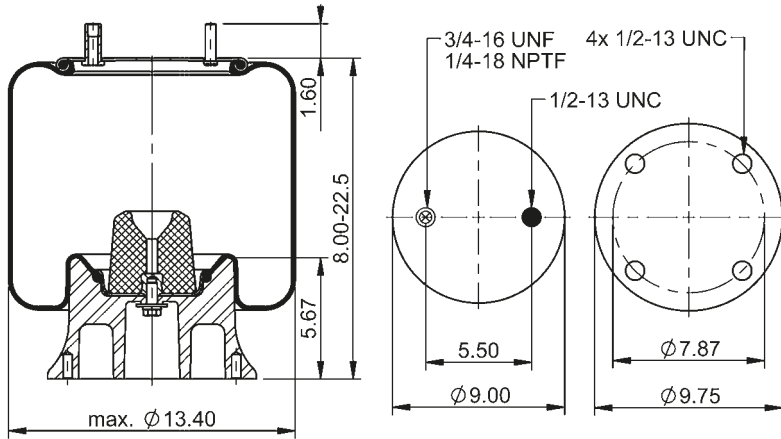

64371



**lb** 17.1 lb **No.** 9311400

**Cross-reference | Cruce de Referencia**

Firestone	W01-358-9275
Goodyear	1R13-117

**Manufacturer | Fabricante**

Loadguard	SC2464
Reyco	6248
Ridewell	1003589275C
SAF Holland	57009275

- 1/4-18 NPTF: max. 22 lb-ft
- 1/2-13 UNC: max. 35 lb-ft
- 3/4-16 UNF: max. 50 lb-ft

### 9 10B-17.5 A 362

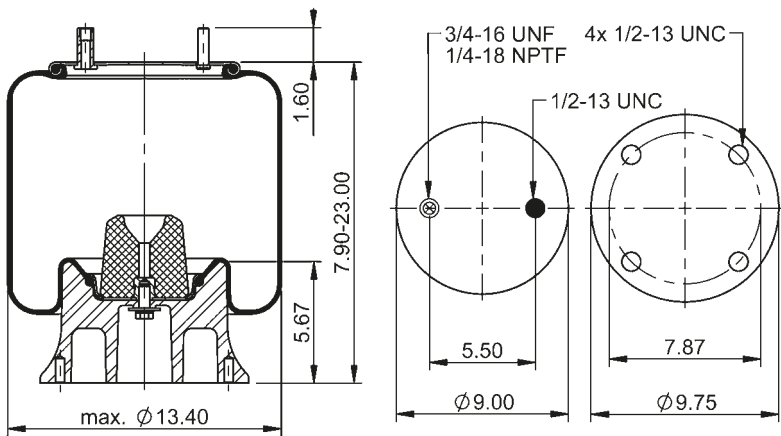

65359



**lb** 17.1 lb **No.** 9311400

**Cross-reference | Cruce de Referencia**

Firestone	W01-358-9274
-----------	--------------

**Manufacturer | Fabricante**

Ridewell	1003589274C
----------	-------------

- 1/4-18 NPTF: max. 22 lb-ft
- 1/2-13 UNC: max. 35 lb-ft
- 3/4-16 UNF: max. 50 lb-ft

### 9 10B-17.5 P 554 (BK)

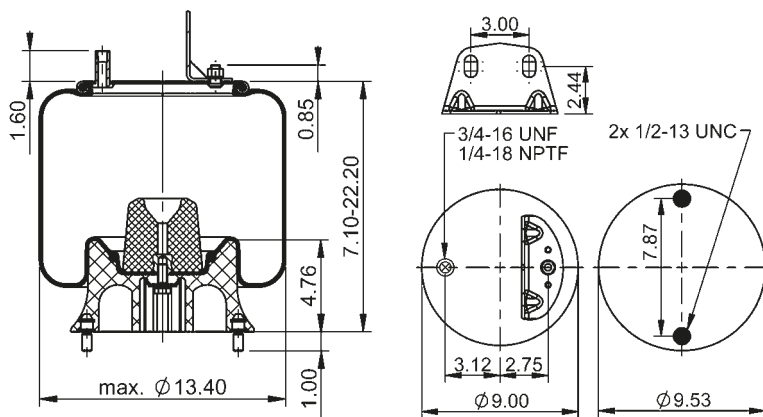

69652



**lb** 14.3 lb **No.** 9308245

**Cross-reference | Cruce de Referencia**

Firestone	W01-358-9491
Goodyear	1R12-373
	1R12-553

**Manufacturer | Fabricante**

SAF Holland	90557206
-------------	----------

- 1/4-18 NPTF: max. 22 lb-ft
- 1/2-13 UNC: max. 35 lb-ft
- 3/4-16 UNF: max. 50 lb-ft

### 9 10B-17.5 P 870 (BK)

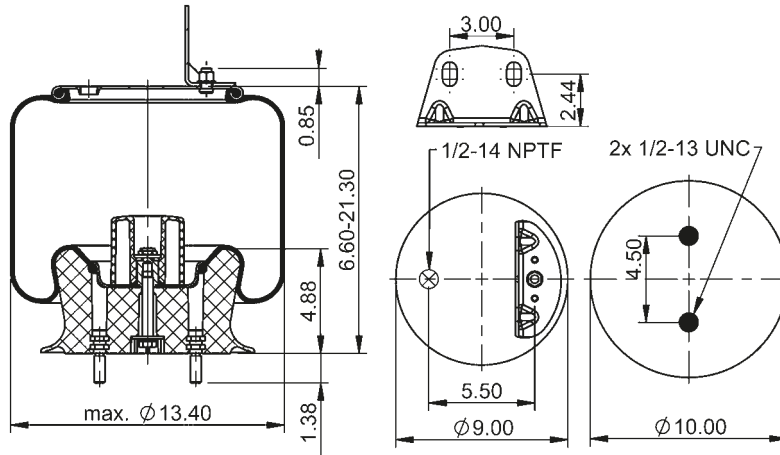

67810



**lb** 15.7 lb **No.** 9308662

**Manufacturer | Fabricante**  
Tuthill 707402-01

**1/2-13 UNC:** max. 35 lb-ft  
**1/2-14 NPTF:** max. 22 lb-ft

### 9 10LP-17.5 P 806 (BK)

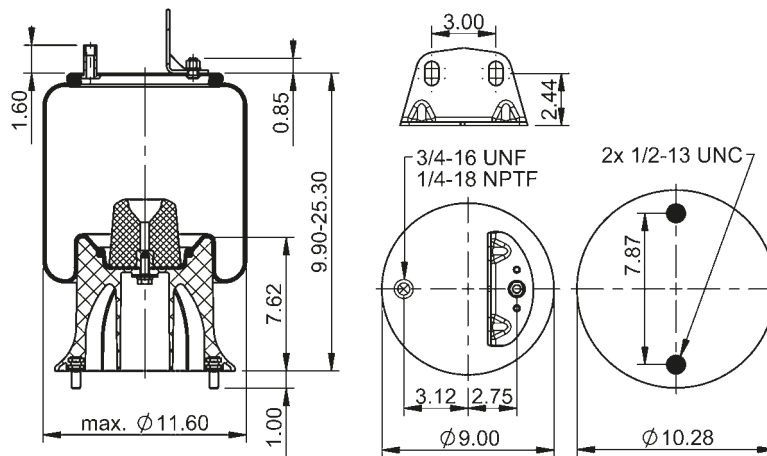

65540



**lb** 17.4 lb **No.** 9308244

**Manufacturer | Fabricante**  
SAF Holland 90557347

**1/4-18 NPTF:** max. 22 lb-ft  
**1/2-13 UNC:** max. 35 lb-ft  
**3/4-16 UNF:** max. 50 lb-ft

### 9 10LP-17.5 P 815 (BK)

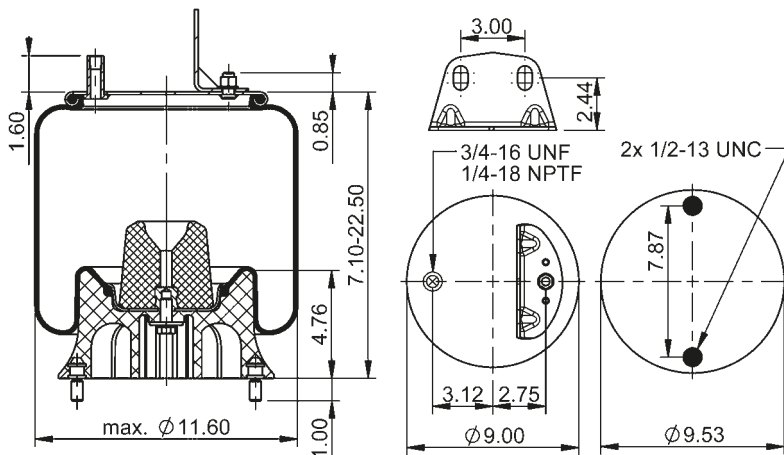

65537



**lb** 15.9 lb **No.** 9308245

**Manufacturer | Fabricante**  
SAF Holland 90557351

**1/4-18 NPTF:** max. 22 lb-ft  
**1/2-13 UNC:** max. 35 lb-ft  
**3/4-16 UNF:** max. 50 lb-ft

### 9 10S-18 P 1066 (BK)

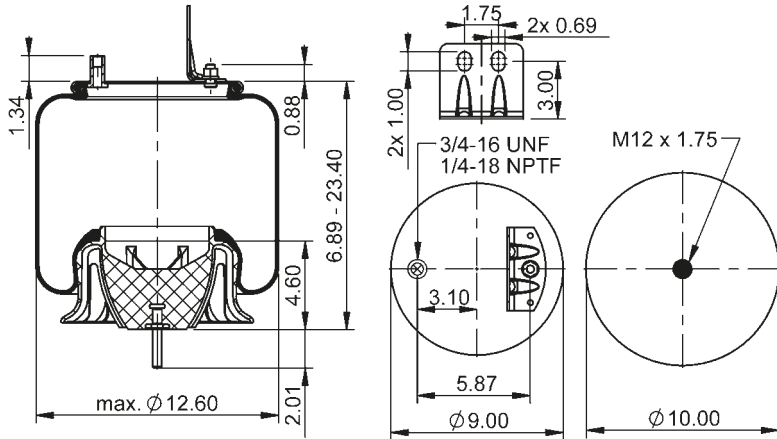

73745



**lb** 11.9 lb **No.** 9316239 9 10B-19.5 P 171

**Cross-reference | Cruce de Referencia**

Firestone W01-358-1190  
Goodyear 1R12-523

**Manufacturer | Fabricante**

Navistar/Fleetrite 3541732C1

- 1/4-18 NPTF: max. 22 lbft
- 3/4-16 UNF: max. 50 lbft
- M12x1.75: max. 30 lbft

### 9 10S-18 P 1067 (BK)

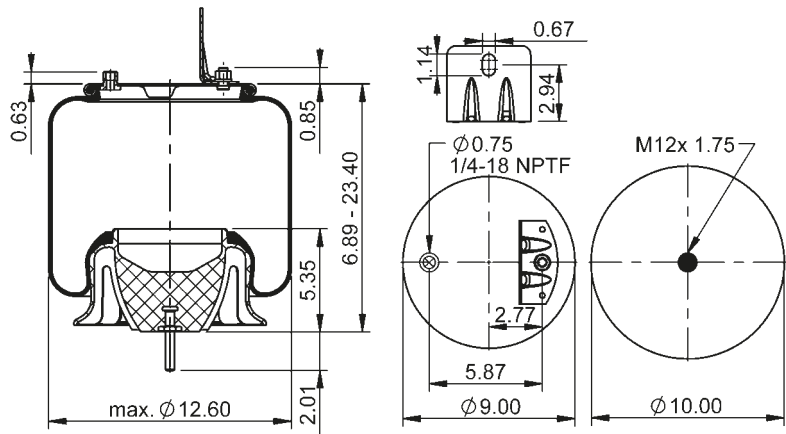

73746



**lb** 12.6 lb **No.** 9316239 9 10B19.5 P 889

**Cross-reference | Cruce de Referencia**

Firestone W01-358-1191  
W01-358-1192  
Goodyear 1R12-432  
1R12-689

**Manufacturer | Fabricante**

Navistar/Fleetrite 350243C94  
3541731C1

- 1/4-18 NPTF: max. 22 lbft

### 9 10-18.5 P 095 (BK)

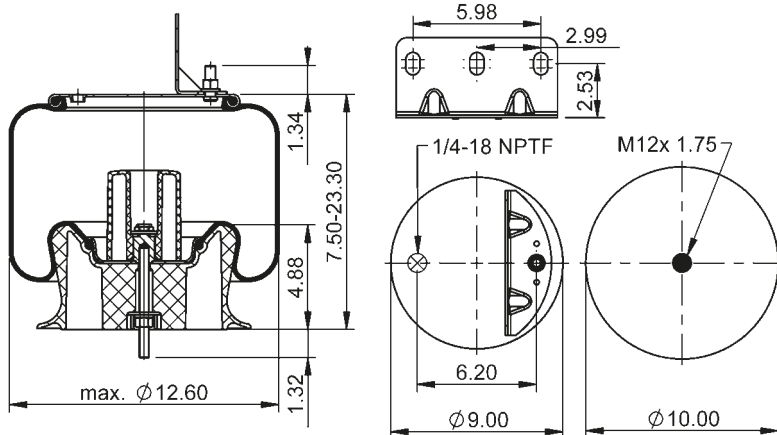

68612



**lb** 14.3 lb **No.** 9313520

**Cross-reference | Cruce de Referencia**

Firestone W01-M58-9372

**Manufacturer | Fabricante**

Hendrickson 58520-2  
58520-2D  
64489-2  
64489-002  
Volvo 8083871  
25173616

- 1/4-18 NPTF: max. 22 lbft

### 9 10-18.5 P 096 (BK)

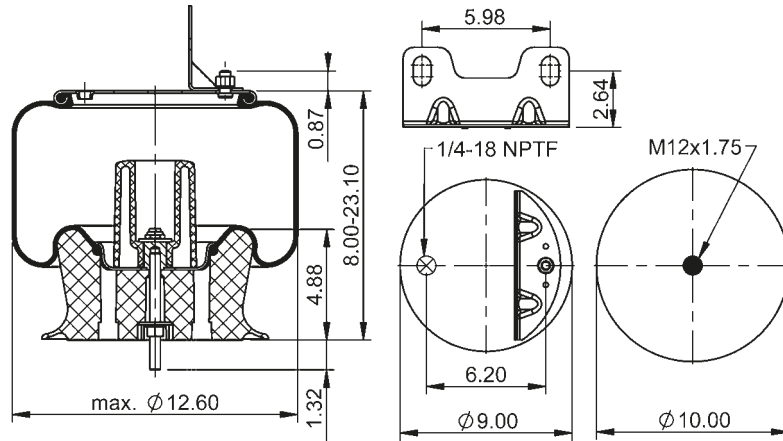

68613



**lb** 16.8 lb **No.** 9308660

**Cross-reference | Cruce de Referencia**  
Firestone W01-M58-9656

**Manufacturer | Fabricante**  
Hendrickson 64651-2  
Mack 57QL53M  
Volvo 25173621

1/4-18 NPTF: max. 22 lb-ft

### 9 10-18.5 P 097

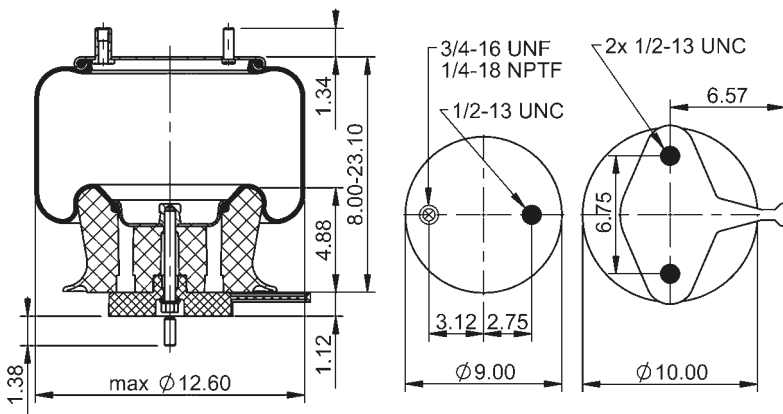

68614



**lb** 19.6 lb **No.** 9308660

**Cross-reference | Cruce de Referencia**  
Firestone W01-358-9654

**Manufacturer | Fabricante**  
Hendrickson 65032-2

1/4-18 NPTF: max. 22 lb-ft  
 1/2-13 UNC: max. 35 lb-ft  
M12x1.75: max. 30 lb-ft

### 9 10-18.5 P 111 (BK)

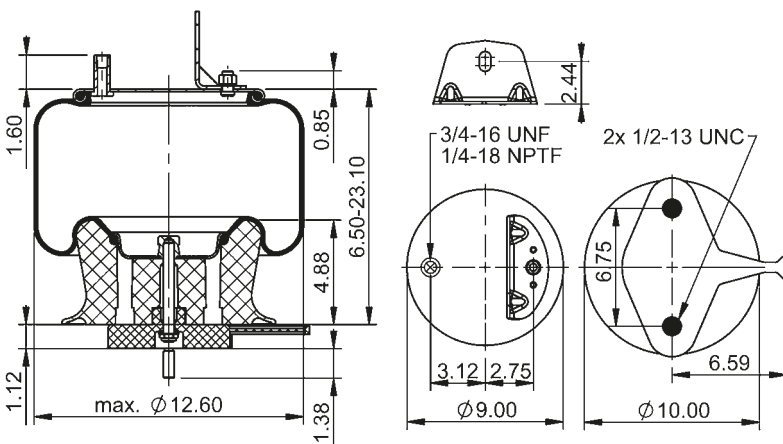

69801



**lb** 21.1 lb **No.** 9308660

**Manufacturer | Fabricante**  
Hendrickson 65183-002

1/4-18 NPTF: max. 22 lb-ft  
 1/2-13 UNC: max. 35 lb-ft  
 3/4-16 UNF: max. 50 lb-ft

### 9 10-18.5 P 406 (BK)

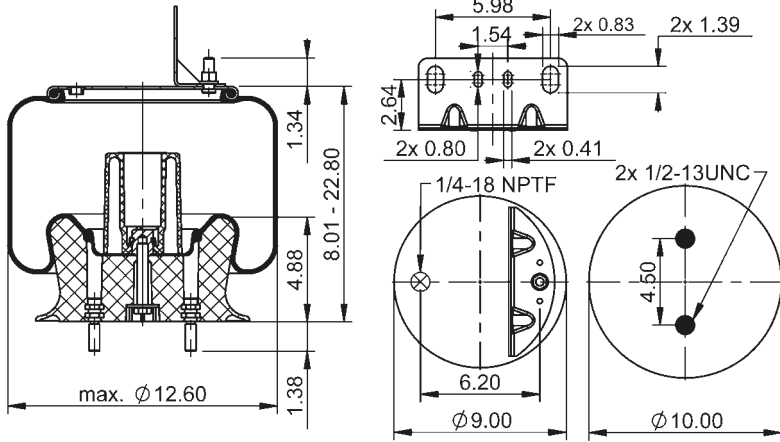

68615



**lb** 17.0 lb **No.** 9308662

**Cross-reference | Cruce de Referencia**

Firestone W01-358-9287  
Goodyear 1R12-424

**Manufacturer | Fabricante**

Ford FOHZ5580A  
F2HZ5580A  
GMC 15963160  
Hendrickson 50405-2  
NS502049  
Loadguard SC2770  
MCI 1622372C1  
Navistar/Fleetrite  
and more

1/4-18 NPTF: max. 22 lbft  
1/2-13 UNC: max. 35 lbft

### 9 10-18.5 P 451 (BK)

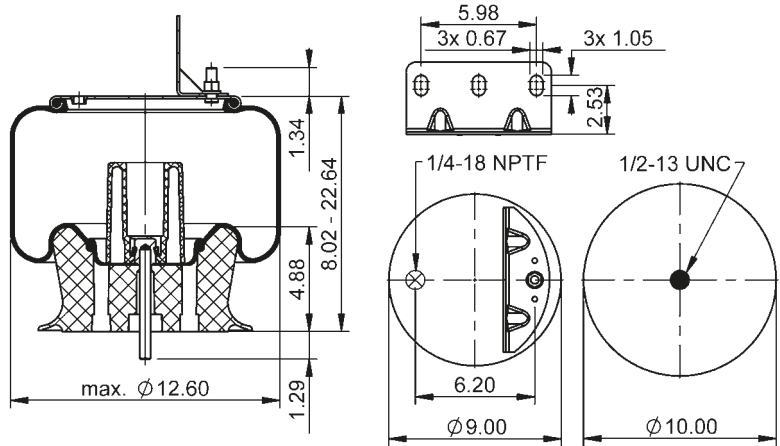

68616



**lb** 16.3 lb **No.** 9308660

**Cross-reference | Cruce de Referencia**

Firestone W01-358-9375  
Goodyear 1R12-404

**Manufacturer | Fabricante**

Hendrickson 50899-1  
50899-2  
Loadguard SC2773  
Mack 364SQ27  
57QL414M

1/4-18 NPTF: max. 22 lbft  
1/2-13 UNC: max. 35 lbft

### 9 10-18.5 P 519 (BK)

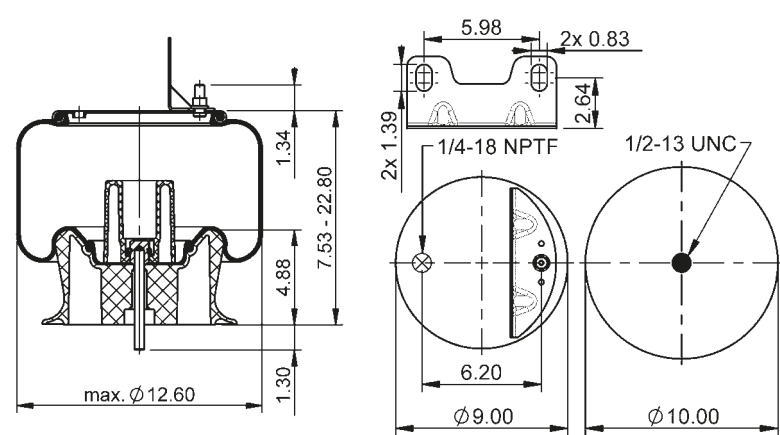

64265



**lb** 16.4 lb **No.** 9313520

**Cross-reference | Cruce de Referencia**

Firestone W01-358-9373  
Goodyear 1R12-403

**Manufacturer | Fabricante**

Hendrickson 57122-1  
57122-2  
MCI 2992101C1  
Navistar/Fleetrite 1R12-1056  
Watson & Chalin AS-0127-G  
AS-0141

1/4-18 NPTF: max. 22 lbft  
1/2-13 UNC: max. 35 lbft



### 9 10-18.5 P 521 (BK)

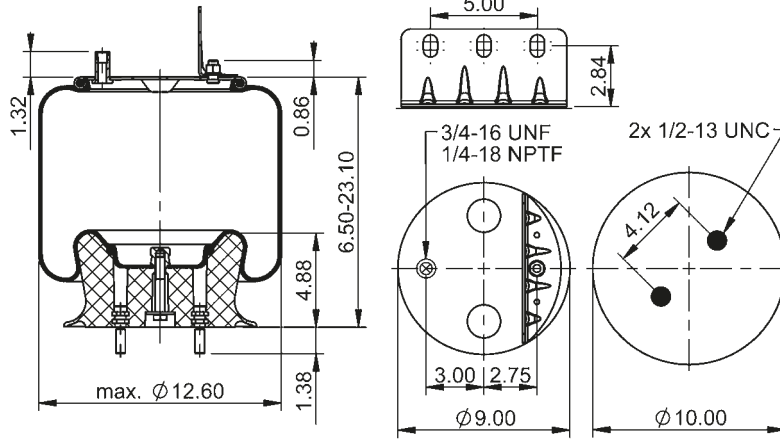

69646



**lb** 15.5 lb **No.** 9308663

**Cross-reference | Cruce de Referencia**  
 Firestone W01-358-9371  
 Goodyear 1R12-401

**Manufacturer | Fabricante**  
 Navistar/Fleetrite 1670043C1  
 1670073C1  
 1686386C1  
 1R12-1062  
 Watson & Chalin AS-0139

1/4-18 NPTF: max. 22 lbft  
 1/2-13 UNC: max. 35 lbft  
 3/4-16 UNF: max. 50 lbft

### 9 10-18.5 P 550 (BK)

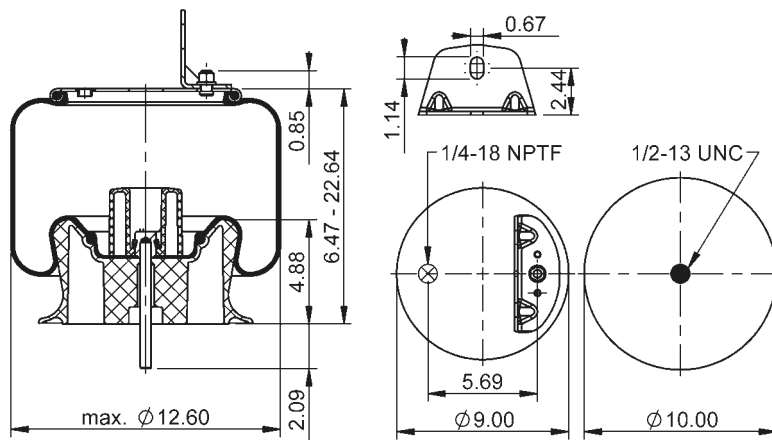

69659



**lb** 15.5 lb **No.** 9313520

**Cross-reference | Cruce de Referencia**  
 Firestone W01-358-9647

**Manufacturer | Fabricante**  
 Hendrickson 58786-2  
 Mack 57QL417M

1/4-18 NPTF: max. 22 lbft  
 1/2-13 UNC: max. 35 lbft

### 9 10-18.5 P 551

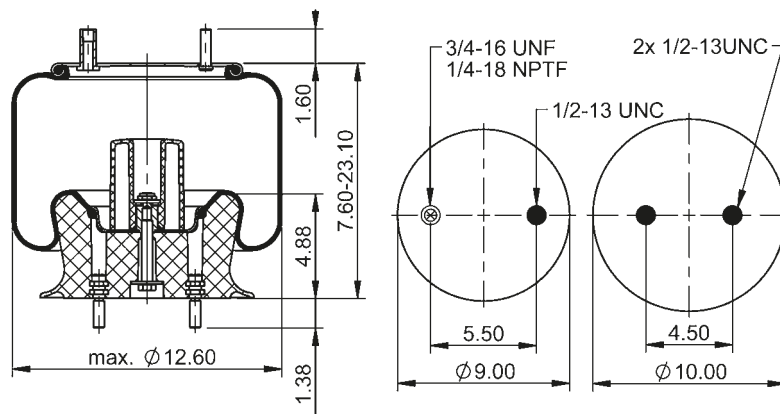

64414



**lb** 15.1 lb **No.** 9308662

**Cross-reference | Cruce de Referencia**  
 Firestone W01-358-9649

**Manufacturer | Fabricante**  
 SAF Holland 90557252  
 Silent Drive AS-9649

1/4-18 NPTF: max. 22 lbft  
 1/2-13 UNC: max. 35 lbft  
 3/4-16 UNF: max. 50 lbft

### 9 10-18.5 P 935 (BK)

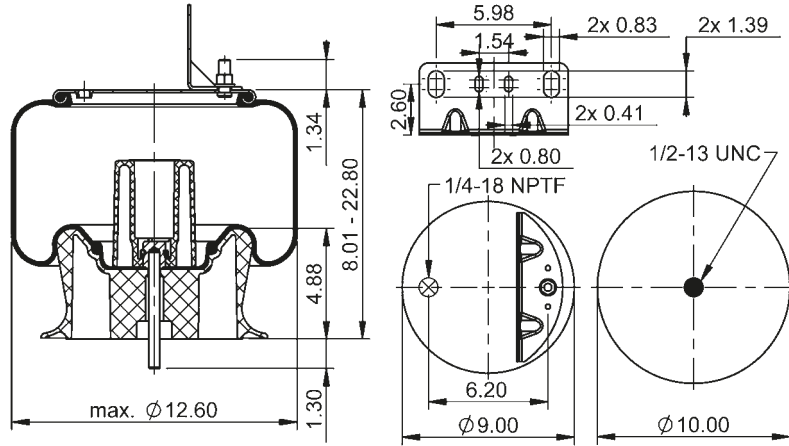

66978



**lb** 16.6 lb **No.** 9313520 **←** 64410

**Cross-reference | Cruce de Referencia**

Firestone W01-358-9297  
Goodyear 1R12-402

**Manufacturer | Fabricante**

Hendrickson 50898-2  
64651-2

1/4-18 NPTF: max. 22 lb-ft  
1/2-13 UNC: max. 35 lb-ft

### 9 10-18.5 P 939 (BK)

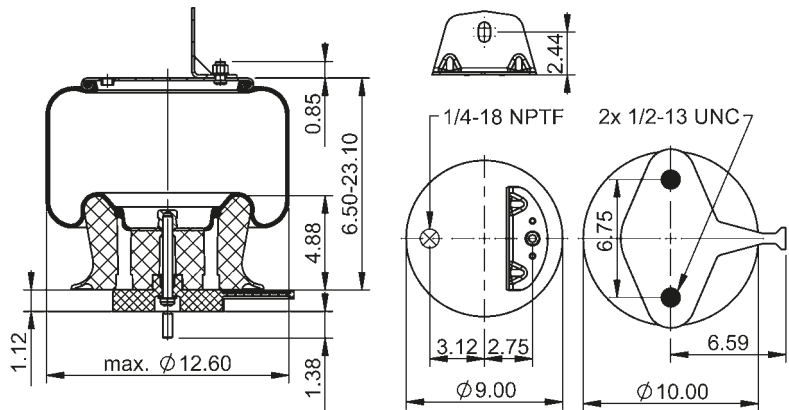

67573



**lb** 21.0 lb **No.** 9308660

**Cross-reference | Cruce de Referencia**

Firestone W01-358-9663  
Goodyear 1R12-1093

**Manufacturer | Fabricante**

Hendrickson 60271-2  
Mack 57QL57M

1/4-18 NPTF: max. 22 lb-ft  
1/2-13 UNC: max. 35 lb-ft

### 9 10-18.5 P 1139 (BK)

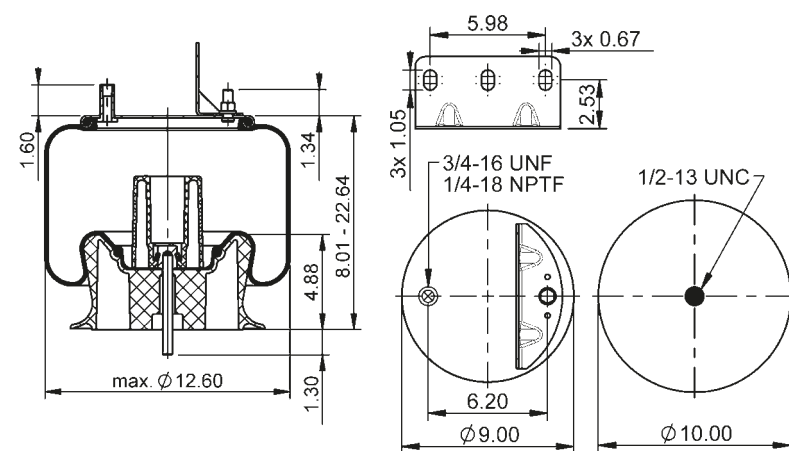

74762



**lb** 16.1 lb **No.** 9313520

**Manufacturer | Fabricante**

Hendrickson 59861-002

1/4-18 NPTF: max. 22 lb-ft  
1/2-13 UNC: max. 35 lb-ft  
3/4-16 UNF: max. 50 lb-ft

### 9 10-18.5 P 1183

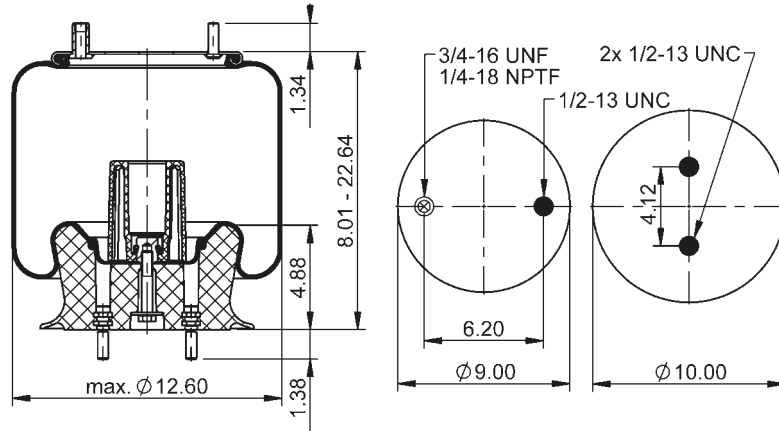

75183



**lb** 14.9 lb **No.** 9308663

**Cross-reference | Cruce de Referencia**  
Goodyear 1R12-274

1/4-18 NPTF: max. 22 lb-ft  
1/2-13 UNC: max. 35 lb-ft  
3/4-16 UNF: max. 50 lb-ft

### 9 10-18.5 P 1322

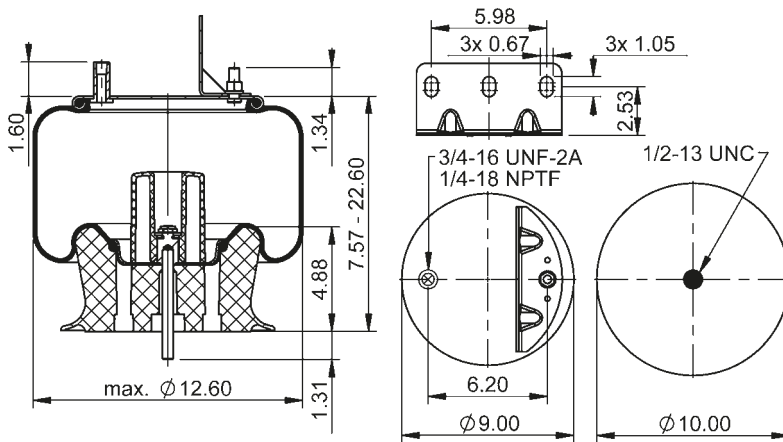

77861



**lb** 16.6 lb **No.** 9308660

**Cross-reference | Cruce de Referencia**  
Firestone W01-358-9641

**Manufacturer | Fabricante**  
Hendrickson 59010-2

1/4-18 NPTF: max. 22 lb-ft  
1/2-13 UNC: max. 35 lb-ft  
3/4-16 UNF: max. 50 lb-ft

### 9 10P-18.5 P 195

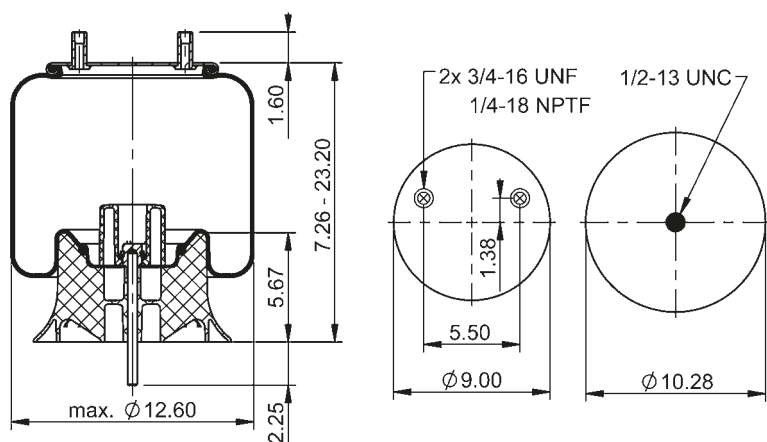

77391



**lb** 14.3 lb **No.** 9314011

**Manufacturer | Fabricante**  
SAF Holland 90557369  
90557404

1/4-18 NPTF: max. 22 lb-ft  
1/2-13 UNC: max. 35 lb-ft  
3/4-16 UNF: max. 50 lb-ft

### 9 10P-18.5 P 886

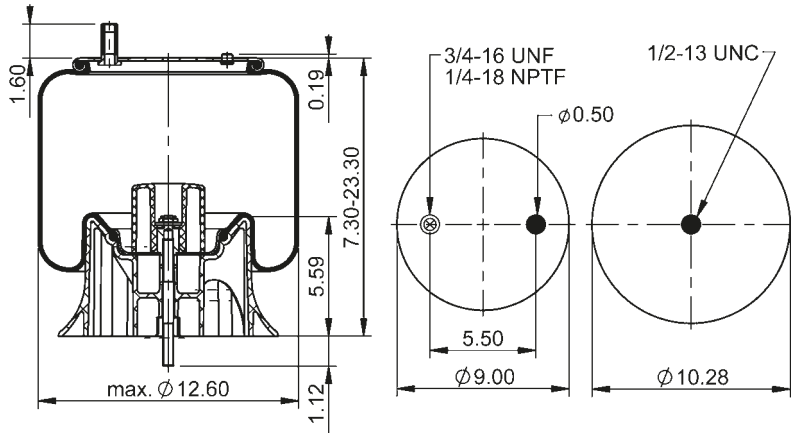

67491



**lb** 14.3 lb **No.** 9308132

**Manufacturer | Fabricante**  
SAF Holland 90557301

- 1/4-18 NPTF: max. 22 lb-ft
- 1/2-13 UNC: max. 35 lb-ft
- 3/4-16 UNF: max. 50 lb-ft

### 9 10P-18.5 A 888

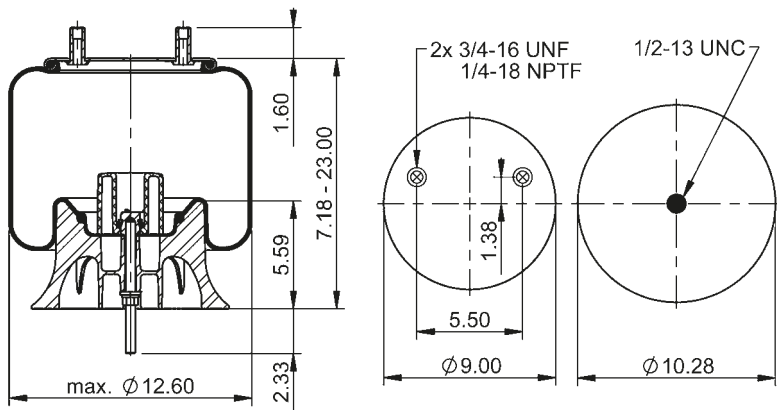

68156



**lb** 16.3 lb **No.** 9313361

**Manufacturer | Fabricante**  
SAF Holland 90557369

- 1/4-18 NPTF: max. 22 lb-ft
- 1/2-13 UNC: max. 35 lb-ft
- 3/4-16 UNF: max. 50 lb-ft

### 9 10P-18.5 A 998

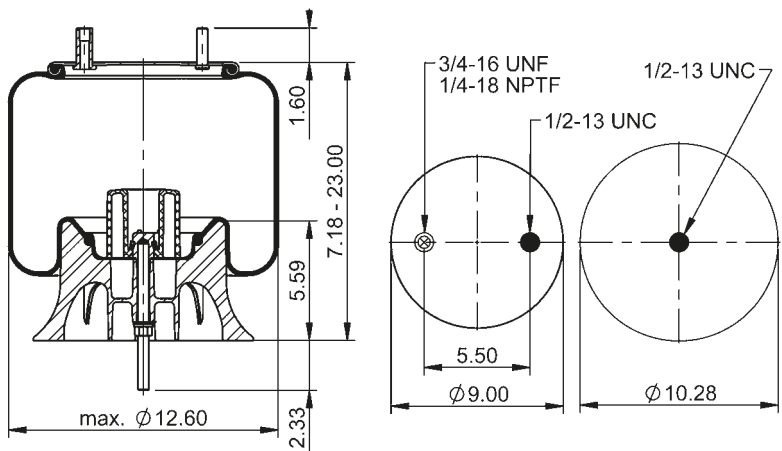

78227



**lb** 16.8 lb **No.** 9313361

**Manufacturer | Fabricante**  
SAF Holland 90557374

- 1/4-18 NPTF: max. 22 lb-ft
- 1/2-13 UNC: max. 35 lb-ft
- 3/4-16 UNF: max. 50 lb-ft

### 9 10P-18.5 P 1113

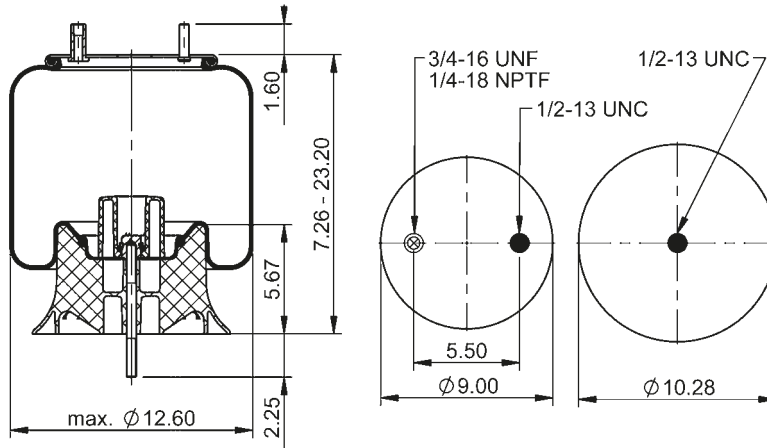

78228



**lb** 14.1 lb **No.** 9314011

**Manufacturer | Fabricante**  
SAF Holland 90557429

- 1/4-18 NPTF: max. 22 lb-ft
- 1/2-13 UNC: max. 35 lb-ft
- 3/4-16 UNF: max. 50 lb-ft

### 9 10P-18.5 P 1207

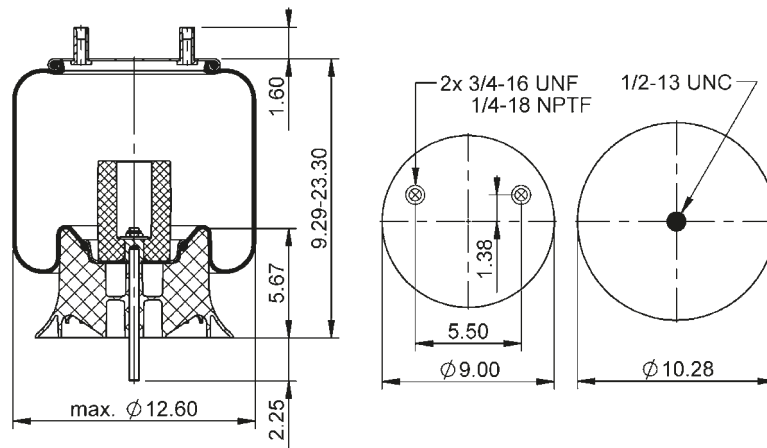

78229



**lb** 13.2 lb **No.** 9314011

**Manufacturer | Fabricante**  
SAF Holland 90557452

- 1/4-18 NPTF: max. 22 lb-ft
- 1/2-13 UNC: max. 35 lb-ft
- 3/4-16 UNF: max. 50 lb-ft

### 9 10-19 A 084

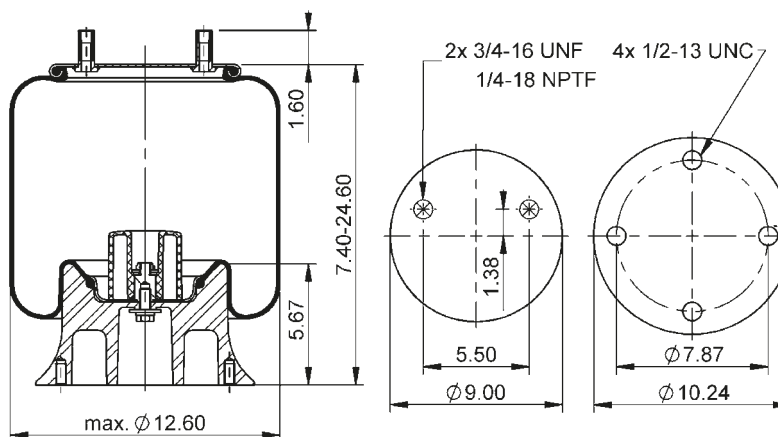

78224



**lb** 16.8 lb **No.** 9305199

**Manufacturer | Fabricante**  
SAF Holland 90557389

- 1/4-18 NPTF: max. 22 lb-ft
- 1/2-13 UNC: max. 35 lb-ft
- 3/4-16 UNF: max. 50 lb-ft

### 9 10-19 P 315

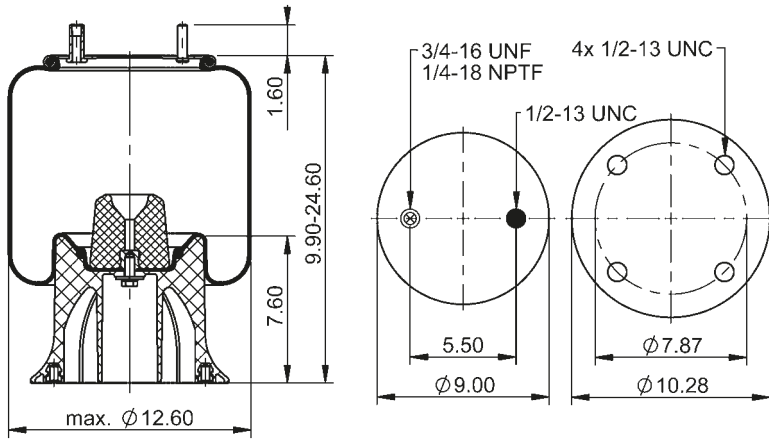

64279



**lb** 17.2 lb **No.** 9308129

**Cross-reference | Cruce de Referencia**

Firestone W01-358-9101  
Goodyear 1R12-103

**Manufacturer | Fabricante**

Hendrickson B-3842  
S-10443  
Reyco 12883-01  
SAF Holland 90557008  
90557009  
90557082  
Volvo 3130490  
85101149

and more

1/4-18 NPTF: max. 22 lbft  
1/2-13 UNC: max. 35 lbft  
3/4-16 UNF: max. 50 lbft

### 9 10-19 P 321

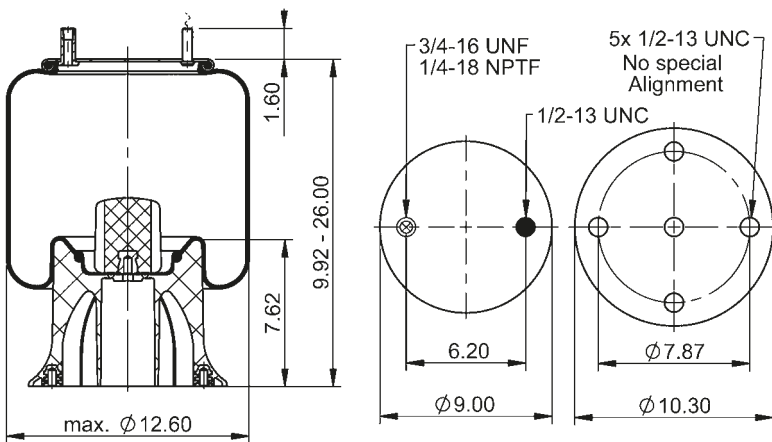

64280



**lb** 17.0 lb **No.** 9308129

**Cross-reference | Cruce de Referencia**

Firestone W01-358-9130  
Goodyear 1R12-281

**Manufacturer | Fabricante**

Dayton 352-9130  
Fruehauf UCE-9393-1  
UCE-9393-3  
UCE-9393-4  
Hendrickson S-13161  
Leland SC2464  
Loadguard SC2102  
SAF Holland 57009130  
and more

1/4-18 NPTF: max. 22 lbft  
1/2-13 UNC: max. 35 lbft  
3/4-16 UNF: max. 50 lbft

### 9 10-19 P 326

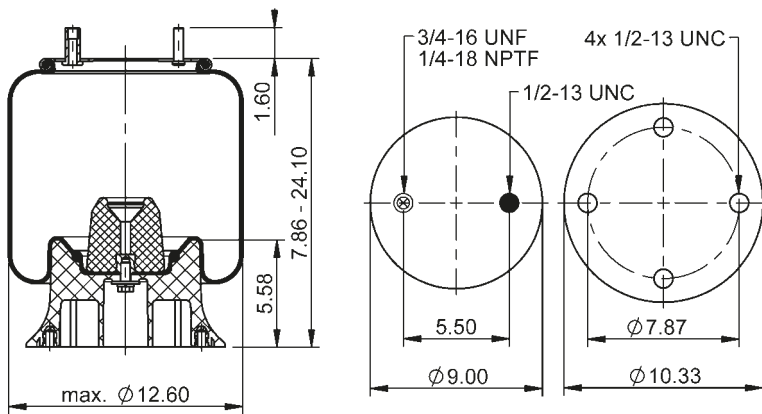

64323



**lb** 15.7 lb **No.** 9308133

**Cross-reference | Cruce de Referencia**

Firestone W01-358-9192  
Goodyear 1R12-185

**Manufacturer | Fabricante**

Meritor 202035  
Hendrickson S-6195  
Navistar/Fleetrite 1681738C1  
1681740C1  
SAF Holland 90557086  
90557108  
Watson & Chalin AS-0038  
AS-0046

and more

1/4-18 NPTF: max. 22 lbft  
1/2-13 UNC: max. 35 lbft  
3/4-16 UNF: max. 50 lbft

### 9 10-19 P 355

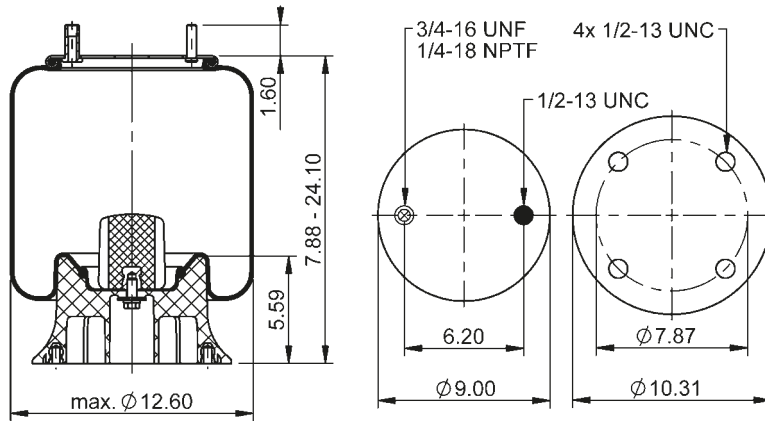

64324



**lb** 15.6 lb **No.** 9308133

**Cross-reference | Cruce de Referencia**

Firestone W01-358-9203  
Goodyear 1R12-395

**Manufacturer | Fabricante**

Dayton 352-9203  
Hendrickson S-2694  
Leland SC2134  
Ridwell 1003589203C  
Taurus AS509-9203

1/4-18 NPTF: max. 22 lb-ft  
1/2-13 UNC: max. 35 lb-ft  
3/4-16 UNF: max. 50 lb-ft

### 9 10-19 P 356

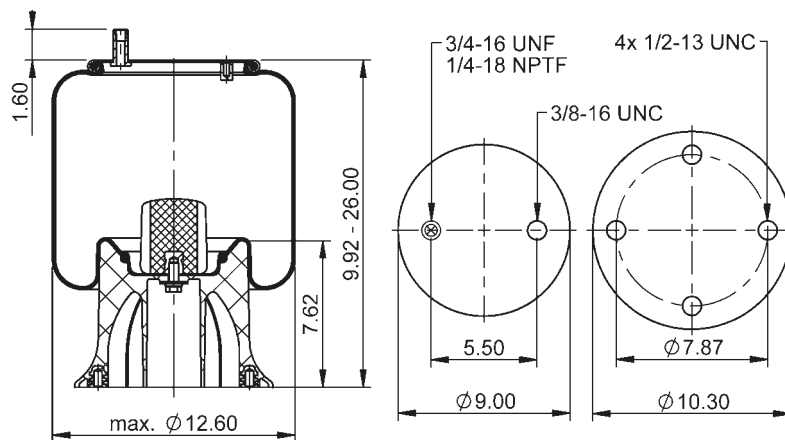

64325



**lb** 17.1 lb **No.** 9308129

**Cross-reference | Cruce de Referencia**

Firestone W01-358-9238  
Goodyear 1R12-145

**Manufacturer | Fabricante**

Dayton 352-9238  
Hendrickson S-5060  
Loadguard SC2109  
Navistar/Fleetrite 1681737C1  
Prevost 63-0178  
SAF Holland 57009238  
Taurus AS509-9238

1/4-18 NPTF: max. 22 lb-ft  
3/8-16 UNC: max. 20 lb-ft  
3/4-16 UNF: max. 50 lb-ft

### 9 10-19 P 357

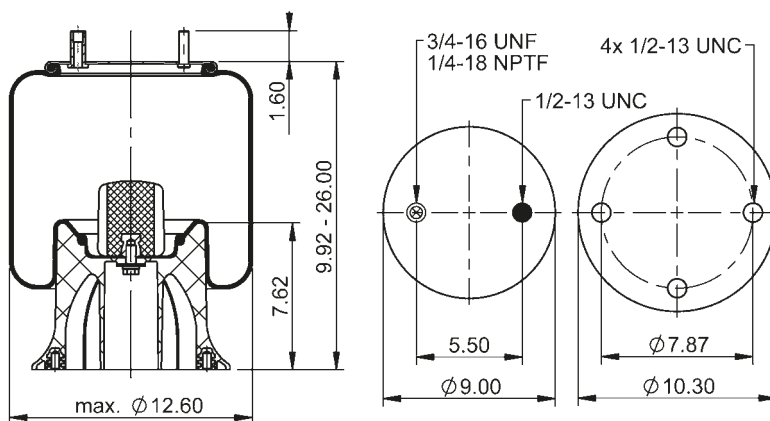

64326



**lb** 17.2 lb **No.** 9308129

**Cross-reference | Cruce de Referencia**

Firestone W01-358-9240  
Goodyear 1R12-275  
1R12-639

**Manufacturer | Fabricante**

Hendrickson S-3842  
S-10352

1/4-18 NPTF: max. 22 lb-ft  
1/2-13 UNC: max. 35 lb-ft  
3/4-16 UNF: max. 50 lb-ft

### 9 10-19 A 358

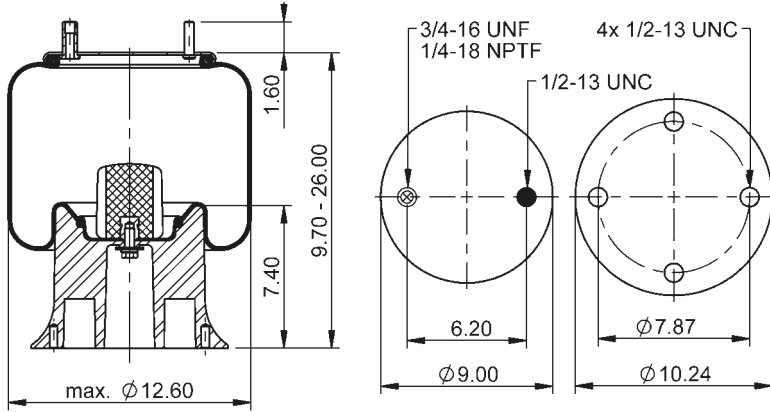

64327



**lb** 19.8 lb **No.** 9305198

**Cross-reference | Cruce de Referencia**  
Goodyear 1R12-261

**Manufacturer | Fabricante**  
Meritor 200041  
Fruehauf UCD-9393-2  
UCE-9393-1  
UCE-9393-2  
UCE-9393-3  
UCE-9393-4

Hendrickson S-10352  
Watson & Chalin AS-0142  
and more

1/4-18 NPTF: max. 22 lb-ft  
1/2-13 UNC: max. 35 lb-ft  
3/4-16 UNF: max. 50 lb-ft

### 9 10-19 P 358

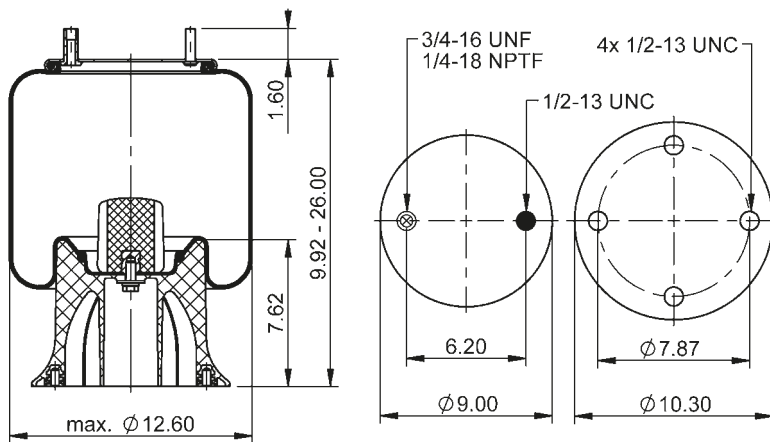

64615



**lb** 17.2 lb **No.** 9308129

**Cross-reference | Cruce de Referencia**  
Firestone W01-358-9241

**Manufacturer | Fabricante**  
Meritor 200041  
Fruehauf UCD-9393-2  
UCE-9393-1  
UCE-9393-2  
UCE-9393-3  
UCE-9393-4

Hendrickson S-10352  
Watson & Chalin AS-0142  
and more

1/4-18 NPTF: max. 22 lb-ft  
1/2-13 UNC: max. 35 lb-ft  
3/4-16 UNF: max. 50 lb-ft

### 9 10-19 P 359

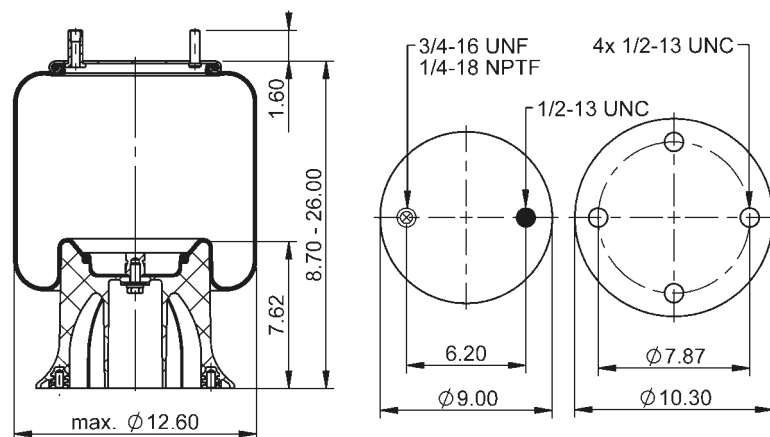

64328



**lb** 15.0 lb **No.** 9308129

**Cross-reference | Cruce de Referencia**  
Firestone W01-358-9350

1/4-18 NPTF: max. 22 lb-ft  
1/2-13 UNC: max. 35 lb-ft  
3/4-16 UNF: max. 50 lb-ft



### 9 10-19 P 383

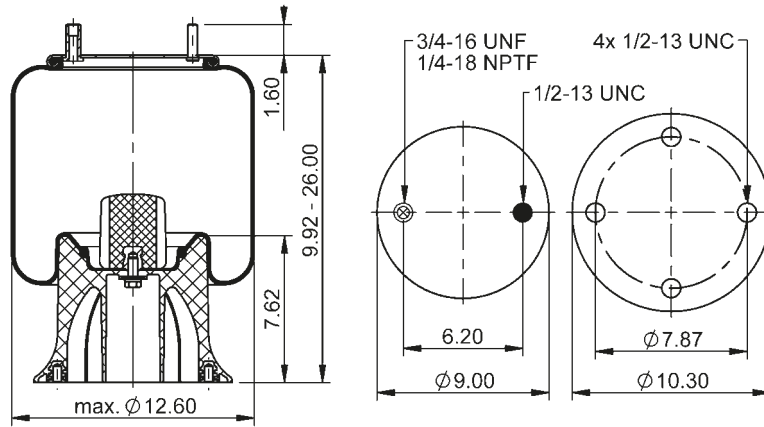

64281



**lb** 17.2 lb **No.** 9308129

**Cross-reference | Cruce de Referencia**

Firestone	W01-358-9394
	W01-358-9241
Goodyear	1R12-279

**Manufacturer | Fabricante**

Meritor	200041
Fruehauf	UCD-9393-2
	UCE-9393-1
	UCE-9393-2
	UCE-9393-3
	UCE-9393-4
Hendrickson	S-10352
Watson & Chalin	AS-0142
and more	

1/4-18 NPTF: max. 22 lb-ft  
 1/2-13 UNC: max. 35 lb-ft  
 3/4-16 UNF: max. 50 lb-ft

### 9 10-19 P 390

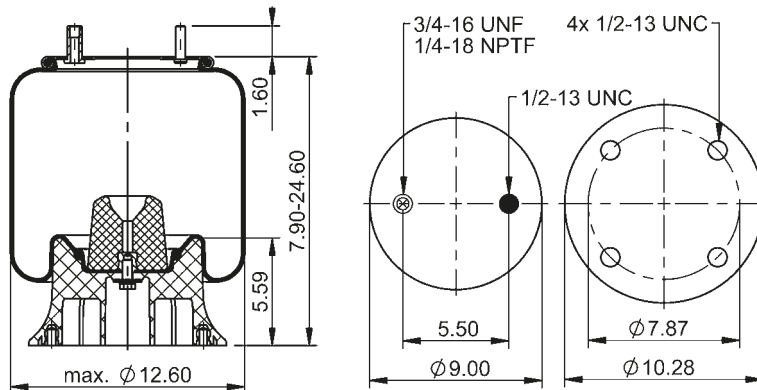

64331



**lb** 15.7 lb **No.** 9308133

**Cross-reference | Cruce de Referencia**

Firestone	W01-358-9245
Goodyear	1R12-446

**Manufacturer | Fabricante**

Granning	6396
Loadguard	SC2134
Ridewell	1003589245C

1/4-18 NPTF: max. 22 lb-ft  
 1/2-13 UNC: max. 35 lb-ft  
 3/4-16 UNF: max. 50 lb-ft

### 9 10-19 P 435

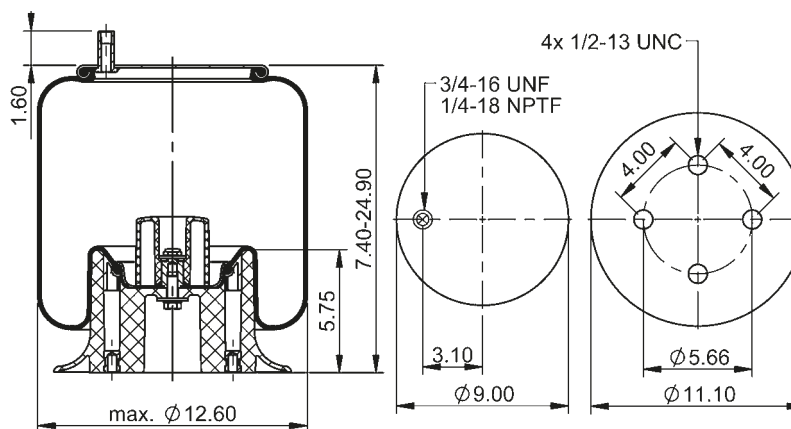

64288



**lb** 14.0 lb **No.** 9308998

**Cross-reference | Cruce de Referencia**

Firestone	W01-358-9265
Goodyear	1R12-375

**Manufacturer | Fabricante**

Brake & Wheel	M3524
Hendrickson	C-20413
	S-20124
	S-20413
Loadguard	SC2759
Volvo	85101155

1/4-18 NPTF: max. 22 lb-ft  
 1/2-13 UNC: max. 35 lb-ft  
 3/4-16 UNF: max. 50 lb-ft

### 9 10-19 P 438

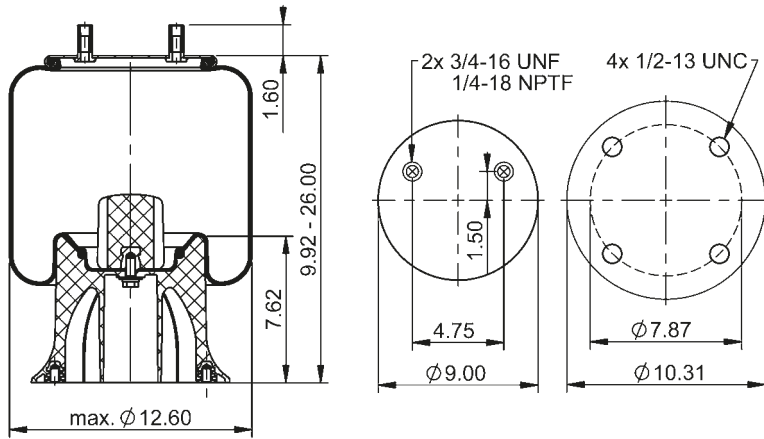

### 64335



**lb** 17.2 lb **No.** 9308129

#### Cross-reference | Cruce de Referencia

Firestone	W01-358-9349
Goodyear	1R12-195

#### Manufacturer | Fabricante

Dayton	352-9349
Hendrickson	S-8988
Loadguard	SC2763
Reyco	17636-01

1/4-18 NPTF: max. 22 lbft  
 1/2-13 UNC: max. 35 lbft  
 3/4-16 UNF: max. 50 lbft

### 9 10-19 P 439

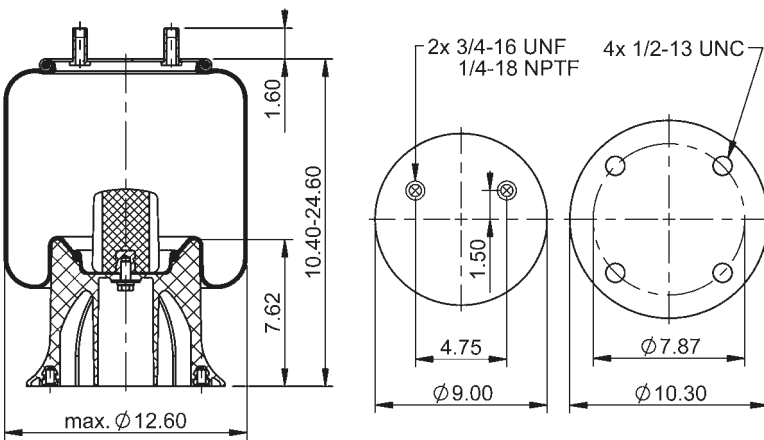

### 65356



**lb** 16.9 lb **No.** 9308129

#### Cross-reference | Cruce de Referencia

Firestone	W01-358-9348
Goodyear	1R12-357

#### Manufacturer | Fabricante

Loadguard	SC2752
SAF Holland	57009348
Taurus	AS509-9348

1/4-18 NPTF: max. 22 lbft  
 1/2-13 UNC: max. 35 lbft  
 3/4-16 UNF: max. 50 lbft

### 9 10-19 P 470

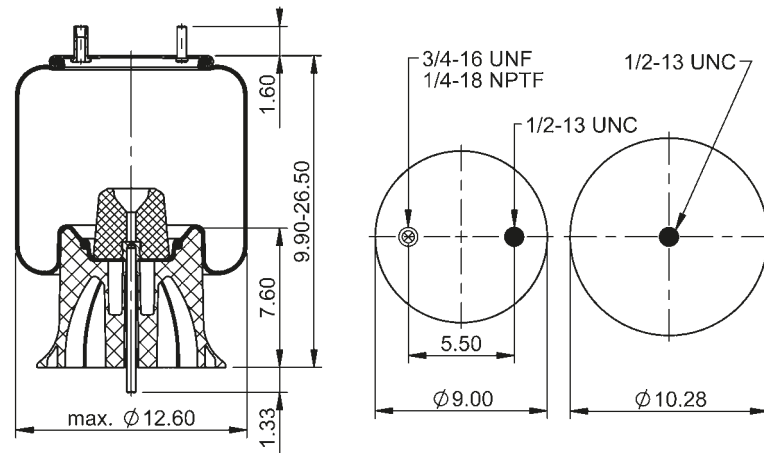

### 64338



**lb** 16.8 lb **No.** 9306248

#### Cross-reference | Cruce de Referencia

Firestone	W01-358-9346
Goodyear	1R12-439

#### Manufacturer | Fabricante

SAF Holland	90557126
Watson & Chalin	AS-0056

1/4-18 NPTF: max. 22 lbft  
 1/2-13 UNC: max. 35 lbft  
 3/4-16 UNF: max. 50 lbft

### 9 10-19 P 472

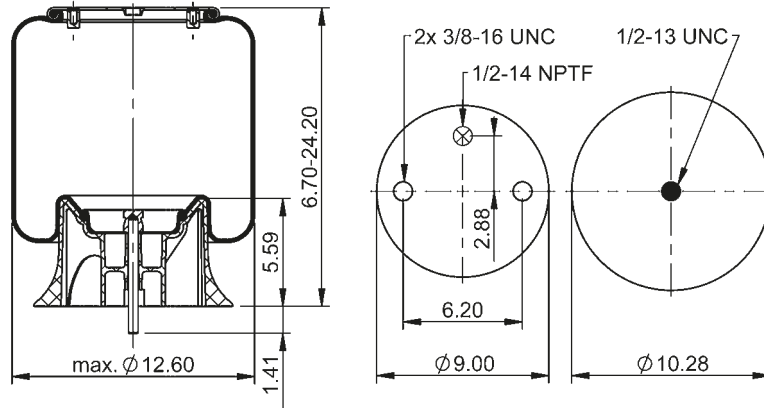

64339



**lb** 12.7 lb **No.** 9314552

**Cross-reference | Cruce de Referencia**  
 Firestone W01-358-8852  
 Goodyear 1R12-568

**Manufacturer | Fabricante**  
 Navistar/Fleetrite 1R12-1058  
 Peterbilt 03-07887

3/8-16 UNC: max. 20 lb-ft  
 1/2-13 UNC: max. 35 lb-ft  
 1/2-14 NPTF: max. 22 lb-ft

### 9 10-19 A 552

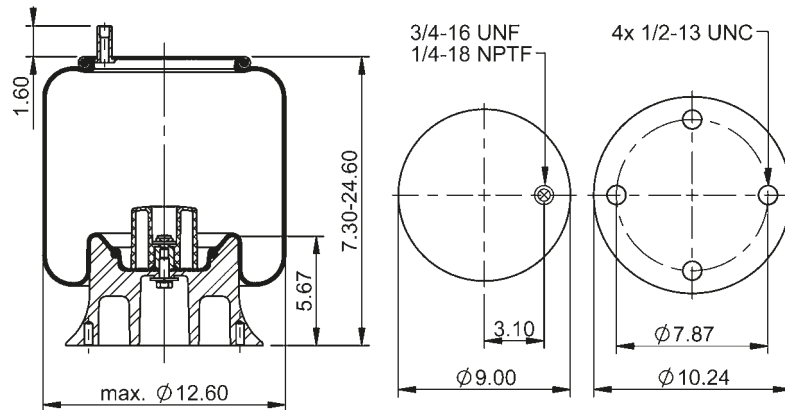

64761



**lb** 16.2 lb **No.** 9305199

**Manufacturer | Fabricante**  
 Tuthill 704671-01

1/4-18 NPTF: max. 22 lb-ft  
 1/2-13 UNC: max. 35 lb-ft  
 3/4-16 UNF: max. 50 lb-ft

### 9 10-19 P 552

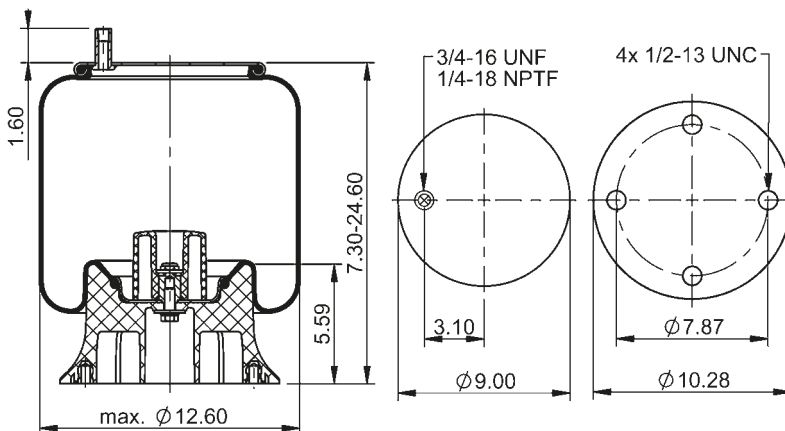

64340



**lb** 14.1 lb **No.** 9308133

**Cross-reference | Cruce de Referencia**  
 Firestone W01-358-8855  
 Goodyear 1R12-613  
 1R12-644

**Manufacturer | Fabricante**  
 Reyco 23521-01

1/4-18 NPTF: max. 22 lb-ft  
 1/2-13 UNC: max. 35 lb-ft  
 3/4-16 UNF: max. 50 lb-ft

### 9 10-19 P 553

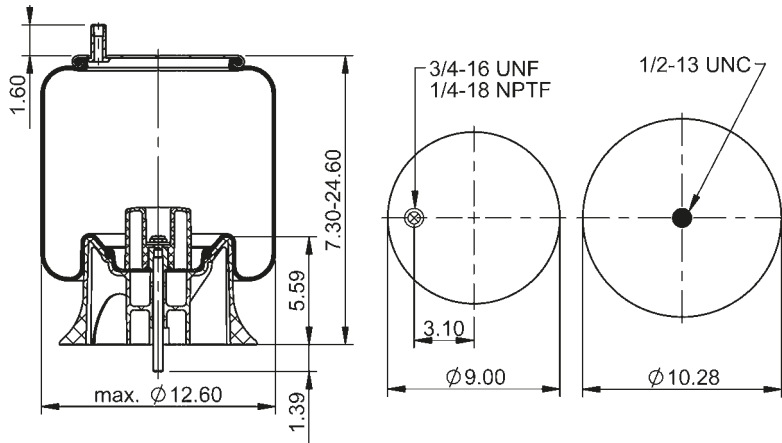

64341



**lb** 13.2 lb **No.** 9314552

**Cross-reference | Cruce de Referencia**  
Firestone W01-358-8856

**Manufacturer | Fabricante**  
Reyco 23521-02

**1/4-18 NPTF:** max. 22 lb-ft  
**1/2-13 UNC:** max. 35 lb-ft  
**3/4-16 UNF:** max. 50 lb-ft

### 9 10-19 P 762

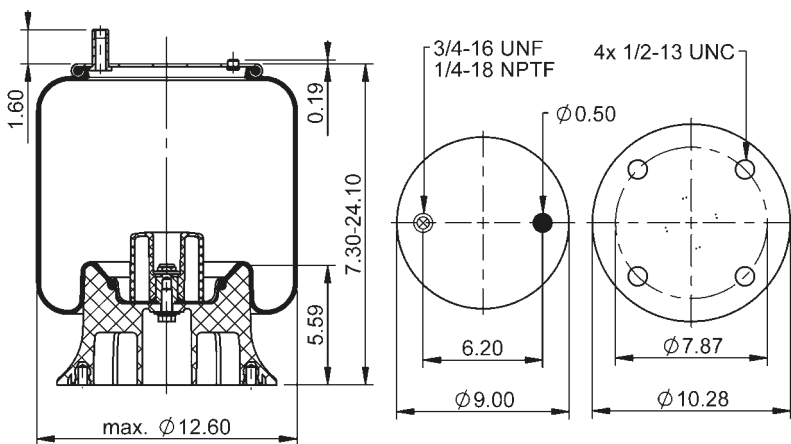

64708



**lb** 14.1 lb **No.** 9308133

**Cross-reference | Cruce de Referencia**  
Firestone W01-358-8861  
Goodyear 1R12-534

**Manufacturer | Fabricante**  
Watson & Chalin AS-0061-1G

**1/4-18 NPTF:** max. 22 lb-ft  
**1/2-13 UNC:** max. 35 lb-ft  
**3/4-16 UNF:** max. 50 lb-ft

### 9 10-19 P 765

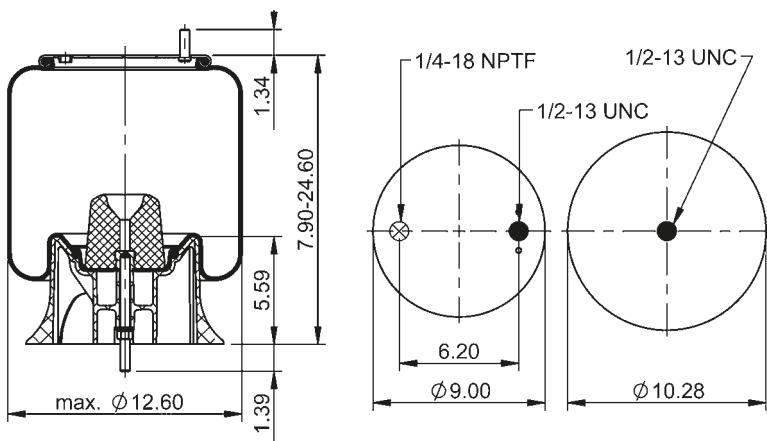

64711



**lb** 14.7 lb **No.** 9314552

**Cross-reference | Cruce de Referencia**  
Firestone W01-358-8842

**Manufacturer | Fabricante**  
Link 1103-0058

**1/4-18 NPTF:** max. 22 lb-ft  
**1/2-13 UNC:** max. 35 lb-ft

### 9 10-19 P 796

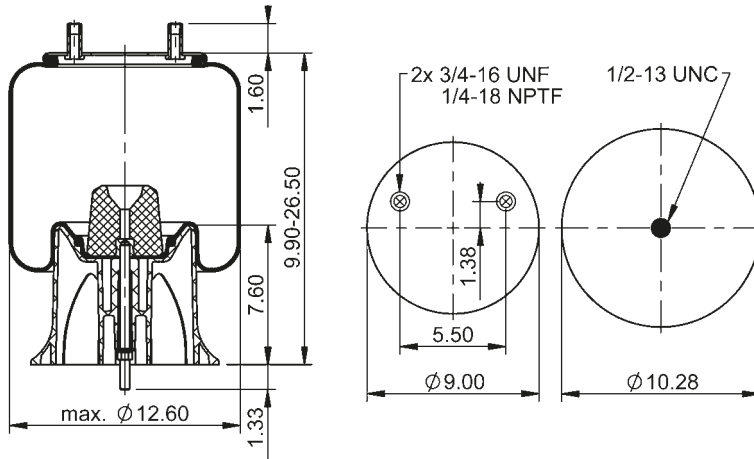

65382



**lb** 17.2 lb **No.** 9306248

**Manufacturer | Fabricante**  
Watson & Chalin AS-0195

- 1/4-18 NPTF: max. 22 lb-ft
- 1/2-13 UNC: max. 35 lb-ft
- 3/4-16 UNF: max. 50 lb-ft

### 9 10-19 P 809

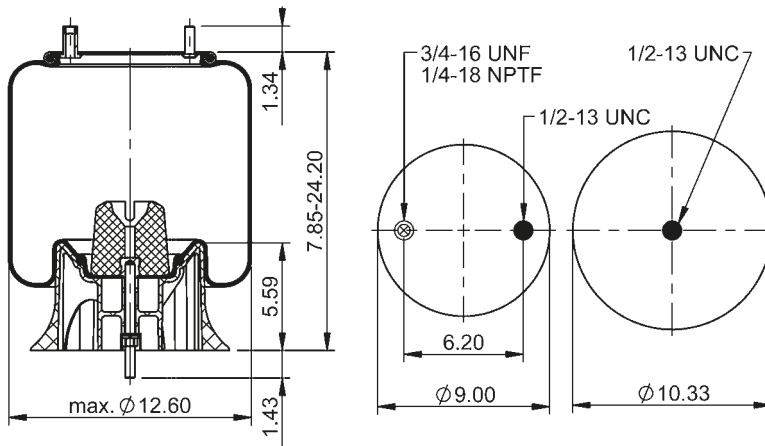

65396



**lb** 16.1 lb **No.** 9314552

**Manufacturer | Fabricante**  
Link 1103 0061

- 1/4-18 NPTF: max. 22 lb-ft
- 1/2-13 UNC: max. 35 lb-ft
- 3/4-16 UNF: max. 50 lb-ft

### 9 10-19 P 814

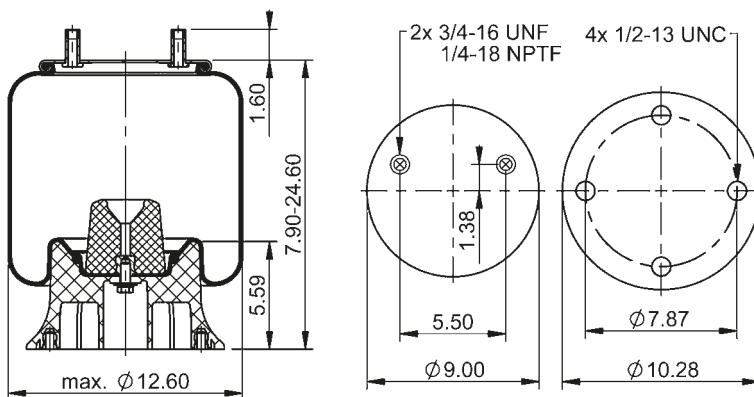

65520



**lb** 16.8 lb **No.** 9308133

**Manufacturer | Fabricante**  
Watson & Chalin AS-0204

- 1/4-18 NPTF: max. 22 lb-ft
- 1/2-13 UNC: max. 35 lb-ft
- 3/4-16 UNF: max. 50 lb-ft

### 9 10-19 A 830

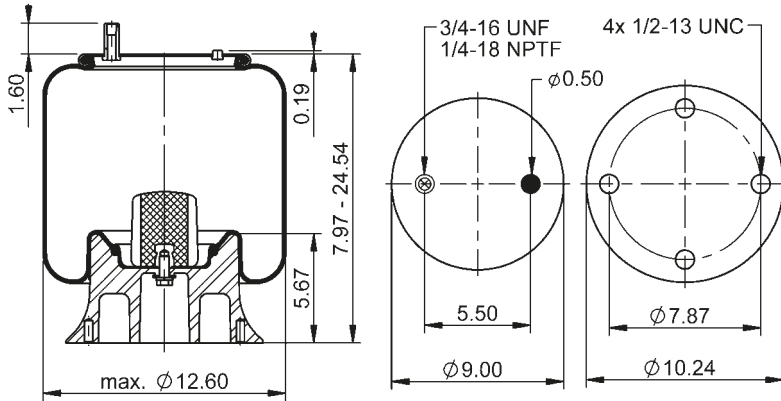

65807



**lb** 17.7 lb **No.** 9305199

**Cross-reference | Cruce de Referencia**

Firestone W01-358-0783  
Goodyear 1R12-467

**Manufacturer | Fabricante**

Ridewell 1000001

- 1/4-18 NPTF: max. 22 lb-ft
- 1/2-13 UNC: max. 35 lb-ft
- 3/4-16 UNF: max. 50 lb-ft

### 9 10-19 P 898

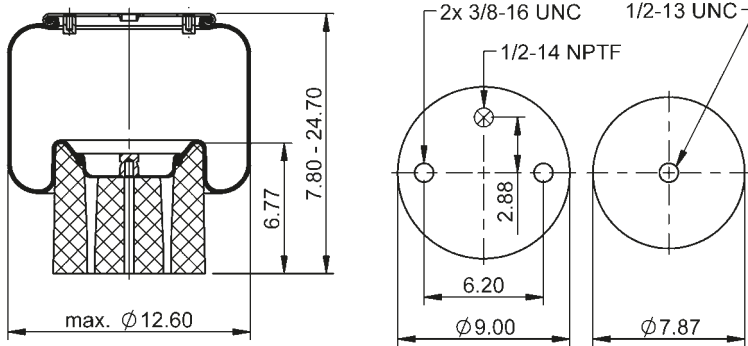

66666



**lb** 13.6 lb **No.** 9308765

**Cross-reference | Cruce de Referencia**

Firestone W01-358-8864

**Manufacturer | Fabricante**

Kenworth C81-1011  
Peterbilt 03-08716

- 3/8-16 UNC: max. 20 lb-ft
- 1/2-13 UNC: max. 35 lb-ft
- 1/2-14 NPTF: max. 22 lb-ft

### 9 10-19 P 901

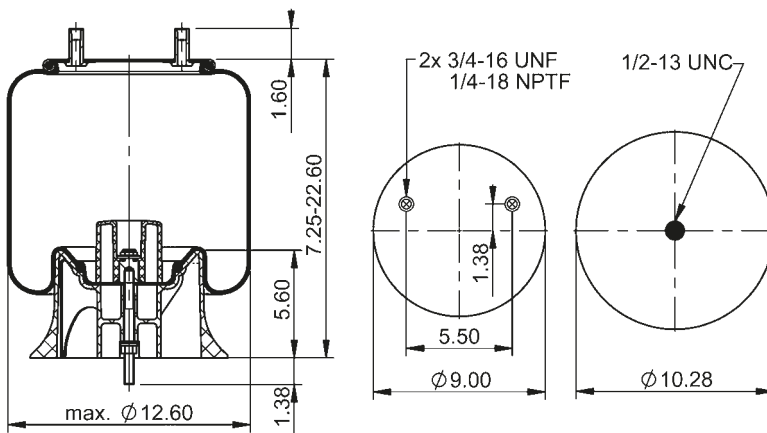

78223



**lb** 14.3 lb **No.** 9308770

**Manufacturer | Fabricante**

SAF Holland 90557376

- 1/4-18 NPTF: max. 22 lb-ft
- 1/2-13 UNC: max. 35 lb-ft
- 3/4-16 UNF: max. 50 lb-ft

### 9 10-19 A 946

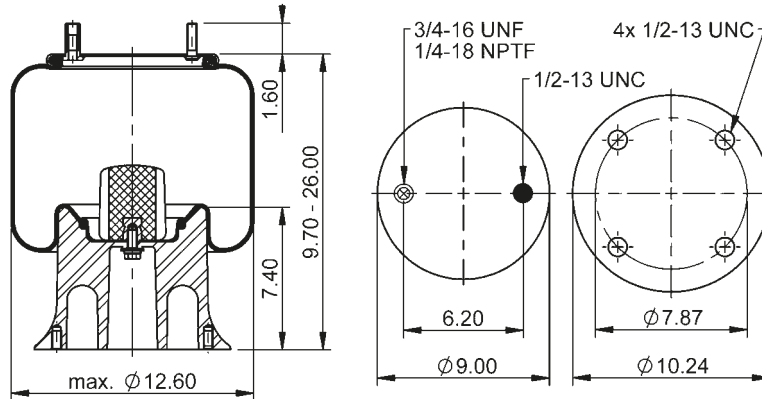

67480



**lb** 20.0 lb **No.** 9305198

**Cross-reference | Cruce de Referencia**

Goodyear 1R12-142

**Manufacturer | Fabricante**

International 1681579C1  
 Loadguard SC2108  
 R&S Truck 10907  
 Suspensions, Inc. 200041

- 1/4-18 NPTF: max. 22 lbft
- 1/2-13 UNC: max. 35 lbft
- 3/4-16 UNF: max. 50 lbft

### 9 10-19 P 946

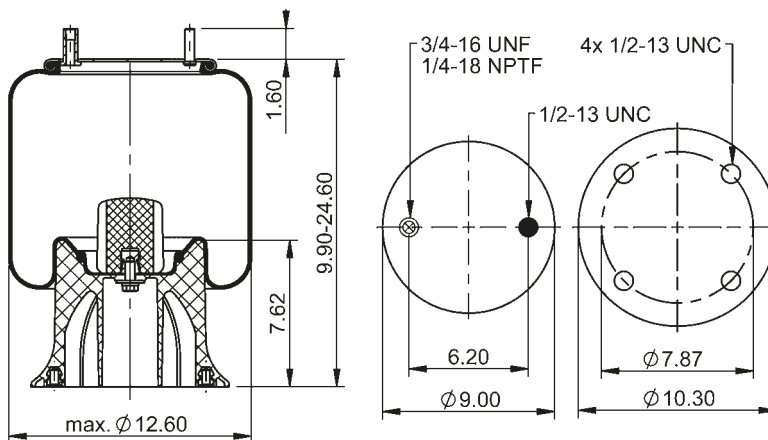

67479



**lb** 17.4 lb **No.** 9308129

**Cross-reference | Cruce de Referencia**

Goodyear 1R12-142

**Manufacturer | Fabricante**

International 1681579C1  
 Loadguard SC2108  
 R&S Truck 10907  
 Suspensions, Inc. 200041

- 1/4-18 NPTF: max. 22 lbft
- 1/2-13 UNC: max. 35 lbft
- 3/4-16 UNF: max. 50 lbft

### 9 10-19 P 973

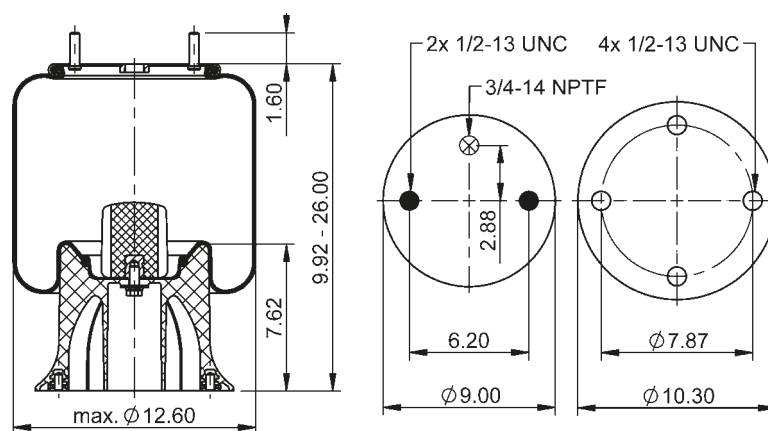

67703



**lb** 17.3 lb **No.** 9308129

**Cross-reference | Cruce de Referencia**

Goodyear 1R12-208

**Manufacturer | Fabricante**

Hendrickson C-10443

- 1/2-13 UNC: max. 35 lbft
- 3/4-14 NPTF: max. 22 lbft

### 9 10-19 P 1138

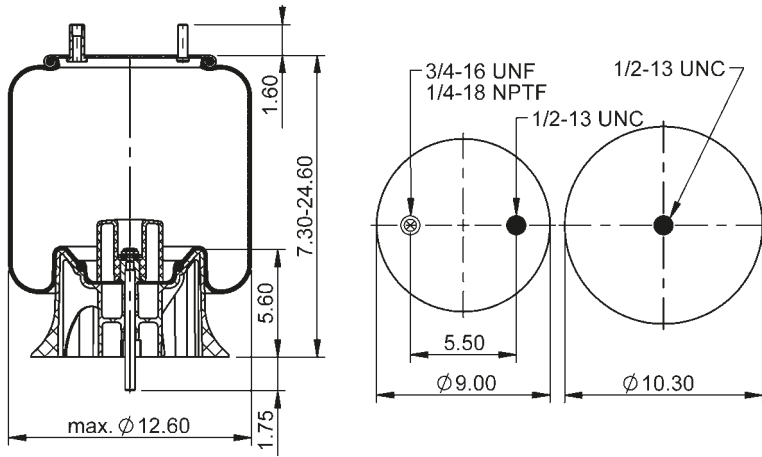

74663



**lb** 13.3 lb **No.** 9308770 **←** 64329

**Cross-reference | Cruce de Referencia**

Firestone W01-358-9243  
Goodyear 1R12-480

**Manufacturer | Fabricante**

SAF Holland 90557112  
Watson & Chalin AS-0061

- 1/4-18 NPTF: max. 22 lb-ft
- 1/2-13 UNC: max. 35 lb-ft
- 3/4-16 UNF: max. 50 lb-ft

### 9 10-19 P 1251

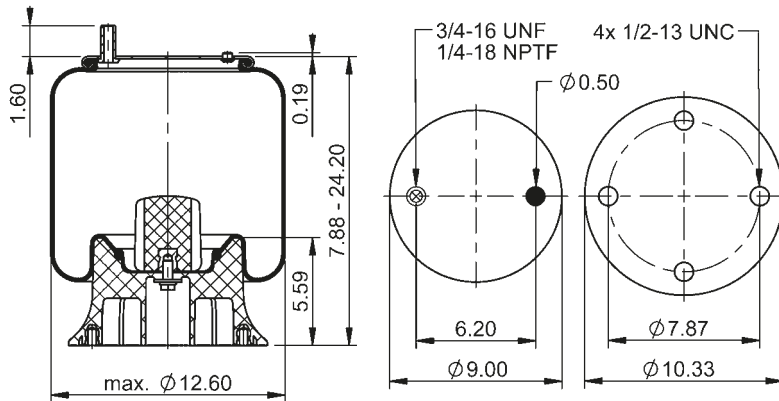

76151



**lb** 15.4 lb **No.** 9308133

**Cross-reference | Cruce de Referencia**

Goodyear 1R12-1028

- 1/4-18 NPTF: max. 22 lb-ft
- 1/2-13 UNC: max. 35 lb-ft
- 3/4-16 UNF: max. 50 lb-ft

### 9 10-19 P 1617

**new**

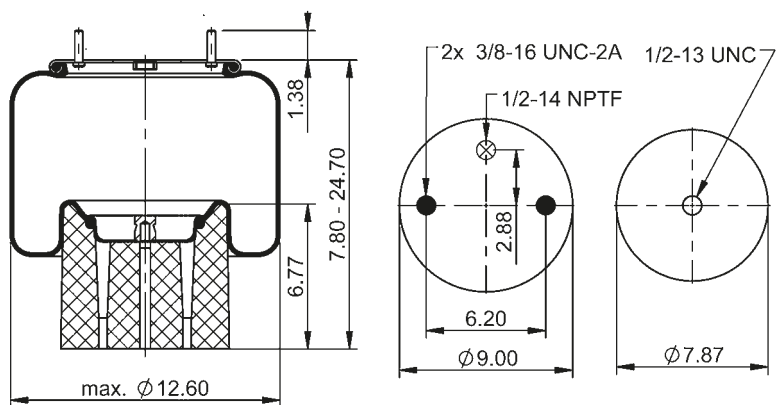

601784



**lb** 13.4 lb **No.** 9308765

**Manufacturer | Fabricante**

Kenworth C81-1013

- 3/8-16 UNC: max. 18 lb-ft
- 1/2-14 NPTF: max. 22 lb-ft



### 9 10P-19 P 1362

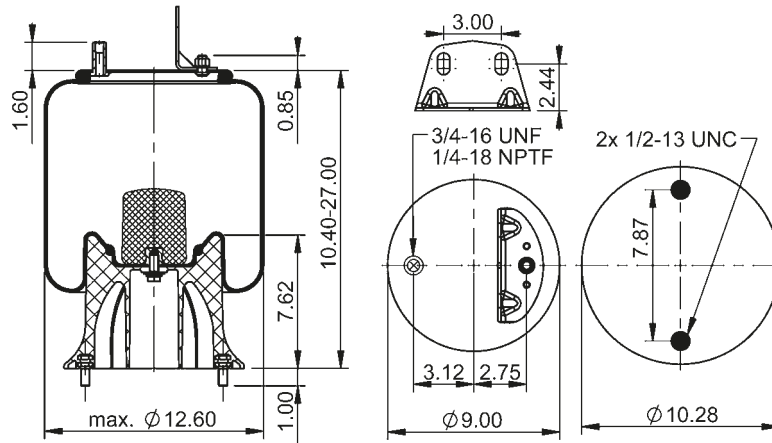

78230



**lb** 17.2 lb **No.** 9308244

**Manufacturer | Fabricante**  
SAF Holland 90557344

**1/4-18 NPTF:** max. 22 lb-ft  
**1/2-13 UNC:** max. 35 lb-ft  
**3/4-16 UNF:** max. 50 lb-ft

### 9 10-19.5 A 801

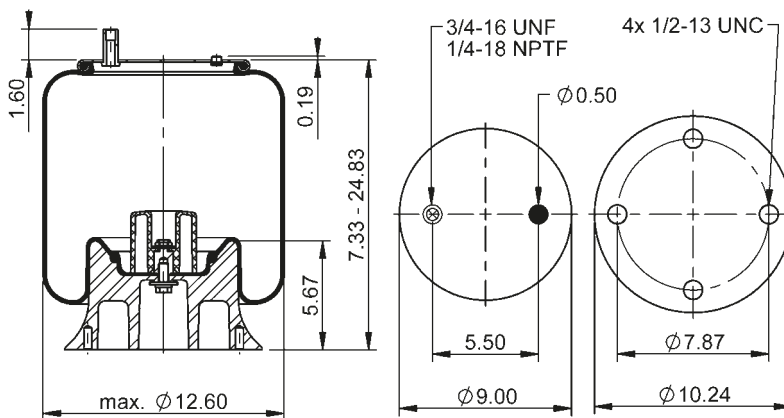

65387



**lb** 16.5 lb **No.** 9305199

**Cross-reference | Cruce de Referencia**  
Goodyear 1R12-467

**Manufacturer | Fabricante**  
Cush C-0060

**1/4-18 NPTF:** max. 22 lb-ft  
**1/2-13 UNC:** max. 35 lb-ft  
**3/4-16 UNF:** max. 50 lb-ft

### 9 10-19.5 P 801

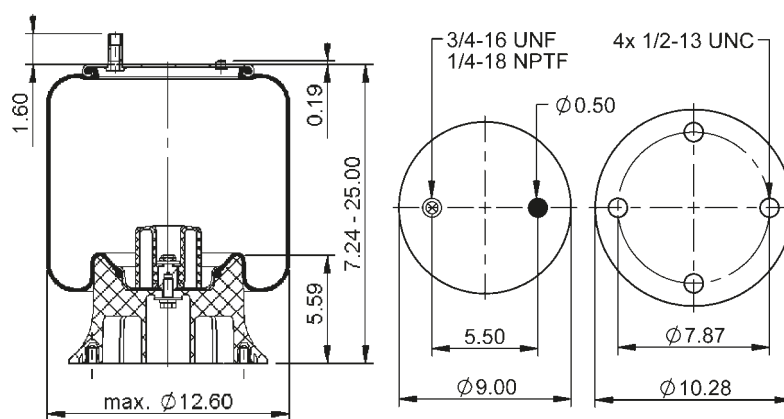

600568



**lb** 14.2 lb **No.** 9308133

**Cross-reference | Cruce de Referencia**  
Goodyear 1R12-607

**1/4-18 NPTF:** max. 22 lb-ft  
**1/2-13 UNC:** max. 35 lb-ft  
**3/4-16 UNF:** max. 50 lb-ft

### 9 10BP-20 P 738

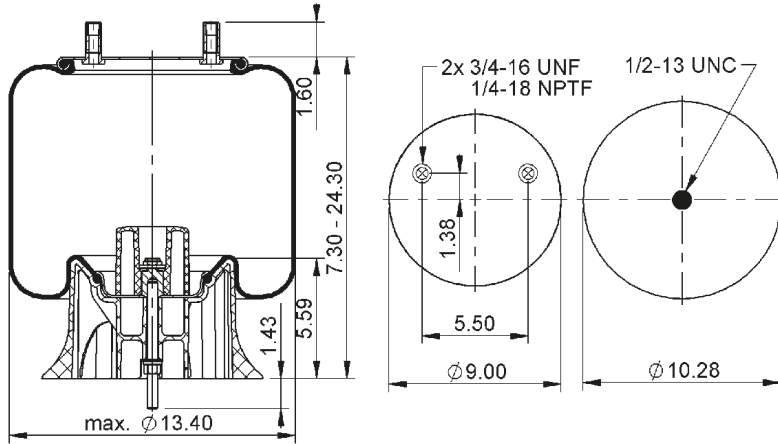

64694



**lb** 13.5 lb **No.** 9314552

**Cross-reference | Cruce de Referencia**  
Firestone W01-358-9646

**Manufacturer | Fabricante**  
Hendrickson S-23611

**1/4-18 NPTF:** max. 22 lb-ft  
**1/2-13 UNC:** max. 35 lb-ft  
**3/4-16 UNF:** max. 50 lb-ft

### 9 10-21 P 360

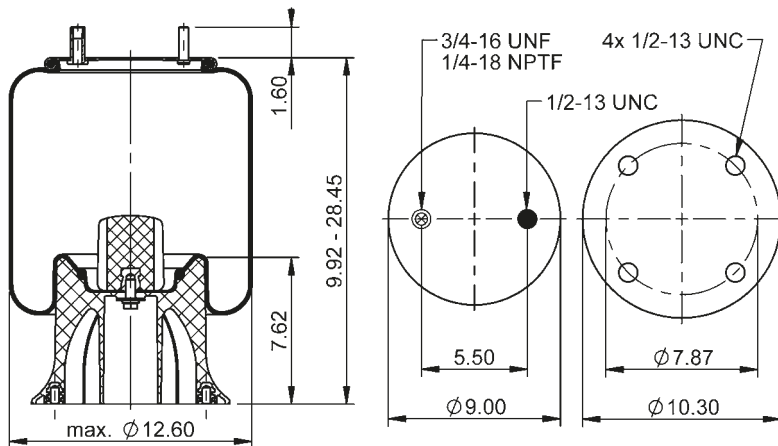

64382



**lb** 17.4 lb **No.** 9308129

**Cross-reference | Cruce de Referencia**  
Firestone W01-358-9320  
Goodyear 1R12-363  
1R12-663

**Manufacturer | Fabricante**  
Loadguard SC2774  
Reyco 24520-01  
Ridewell 1003589320C  
SAF Holland 90557099  
Silent Drive AS-9320

**1/4-18 NPTF:** max. 22 lb-ft  
**1/2-13 UNC:** max. 35 lb-ft  
**3/4-16 UNF:** max. 50 lb-ft

### 9 10-21 A 361

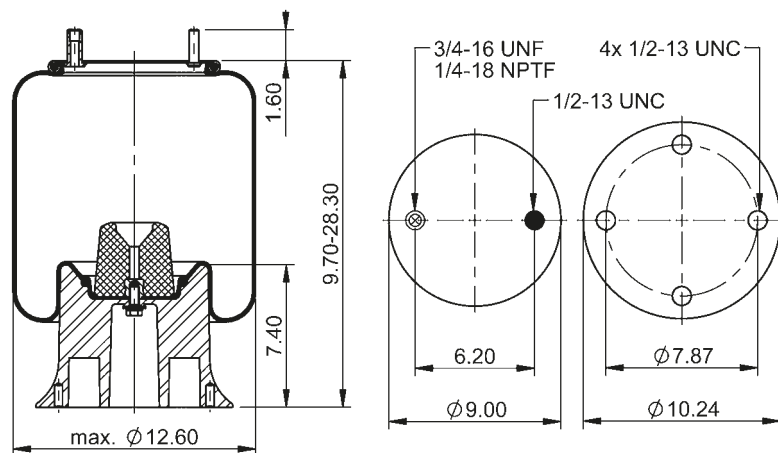

64715



**lb** 20.0 lb **No.** 9305198

**Cross-reference | Cruce de Referencia**  
Firestone W01-358-9321  
Goodyear 1R12-335

**Manufacturer | Fabricante**  
Dayton 352-9321  
Granning 7640  
Hendrickson B-14249  
Loadguard SC2120  
Ridewell 1003589321C  
SAF Holland 57009321  
Volvo 85101160  
Watson & Chalin AS-0036-G  
and more

**1/4-18 NPTF:** max. 22 lb-ft  
**1/2-13 UNC:** max. 35 lb-ft  
**3/4-16 UNF:** max. 50 lb-ft

### 9 10-21 P 361

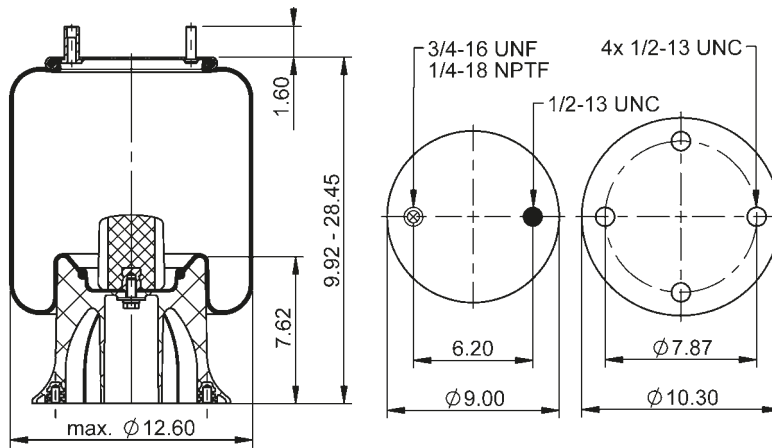

64291



**lb** 17.4 lb **No.** 9308129

**Manufacturer | Fabricante**

Granning	7640
Hendrickson	B-14249
	NS501304
Loadguard	SC2120
Ridewell	1003589321C
SAF Holland	57009321
Volvo	85101160
Watson & Chalin	AS-0036
and more	

1/4-18 NPTF: max. 22 lbft  
 1/2-13 UNC: max. 35 lbft  
 3/4-16 UNF: max. 50 lbft

### 9 10-21 P 448

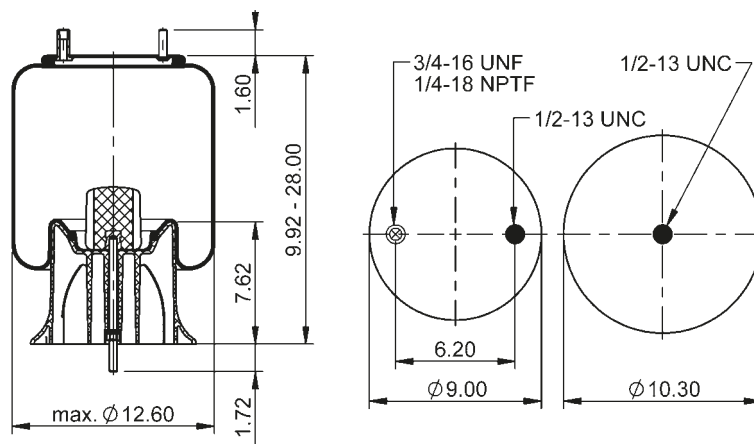

64383



**lb** 17.0 lb **No.** 9306248

**Cross-reference | Cruce de Referencia**

Firestone	W01-358-9370
Goodyear	1R12-580

**Manufacturer | Fabricante**

Ridewell	1003589370C
Watson & Chalin	AS-0057
	AS-0057-1G

1/4-18 NPTF: max. 22 lbft  
 1/2-13 UNC: max. 35 lbft  
 3/4-16 UNF: max. 50 lbft

### 9 10-21 A 505

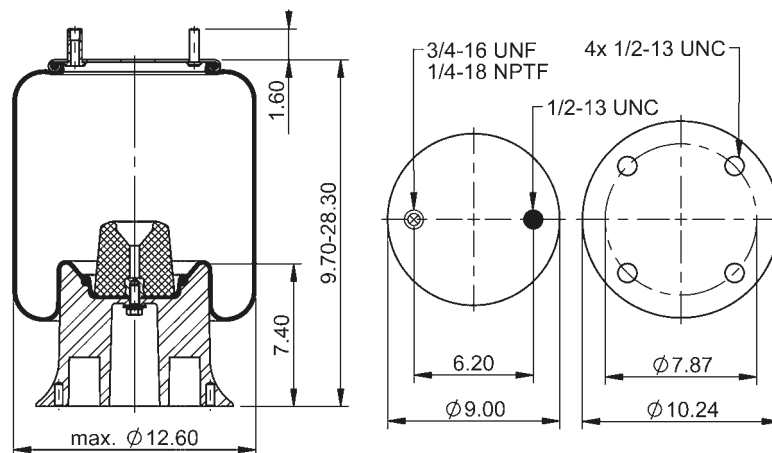

64716



**lb** 20.0 lb **No.** 9305198

**Cross-reference | Cruce de Referencia**

Firestone	W01-358-9367
-----------	--------------

**Manufacturer | Fabricante**

Hendrickson	3319
	B-4375
	B-14249
Loadguard	SC2120
Suspensions, Inc.	201335
Watson & Chalin	AS-0137
	AS-0104

1/4-18 NPTF: max. 22 lbft  
 1/2-13 UNC: max. 35 lbft  
 3/4-16 UNF: max. 50 lbft

### 9 10-21 P 505

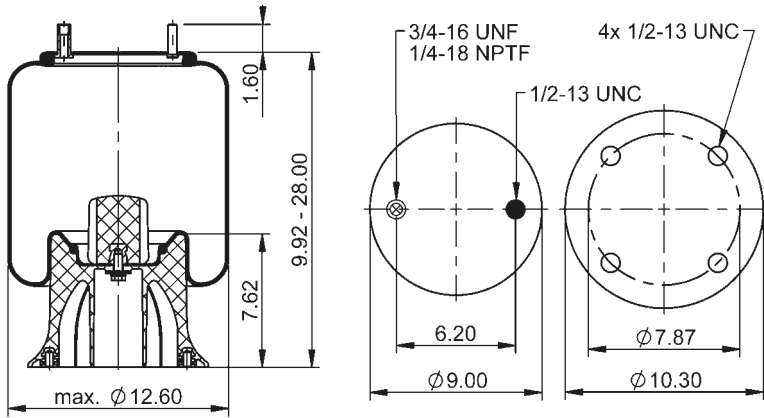

64384



**lb** 17.4 lb **No.** 9308129

**Cross-reference | Cruce de Referencia**

Goodyear 1R12-256

**Manufacturer | Fabricante**

Hendrickson 3319  
B-4375  
B-14249  
Loadguard SC2120  
Suspensions, Inc. 201335  
Watson & Chalin AS-0104  
AS-0137

- 1/4-18 NPTF: max. 22 lb-ft
- 1/2-13 UNC: max. 35 lb-ft
- 3/4-16 UNF: max. 50 lb-ft

### 9 10-21 P 511

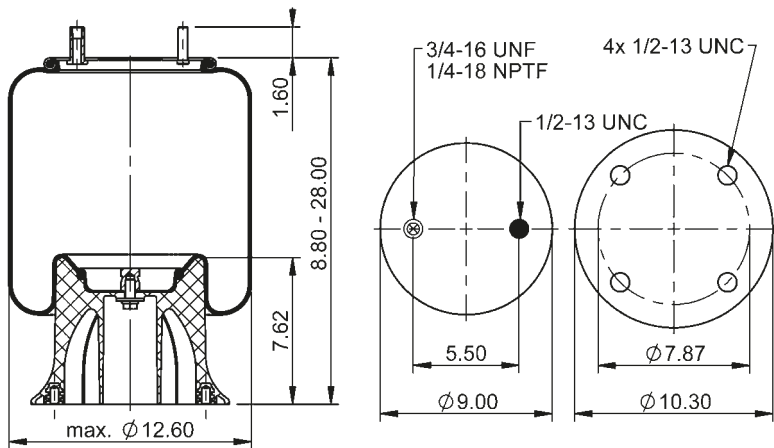

64385



**lb** 15.2 lb **No.** 9308129

**Cross-reference | Cruce de Referencia**

Firestone W01-358-9338  
Goodyear 1R12-637

- 1/4-18 NPTF: max. 22 lb-ft
- 1/2-13 UNC: max. 35 lb-ft
- 3/4-16 UNF: max. 50 lb-ft

### 9 10-21 P 817

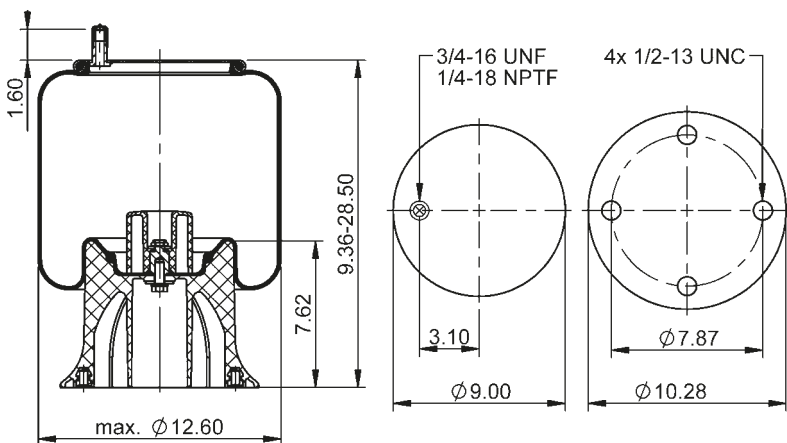

65649



**lb** 16.3 lb **No.** 9308129

**Cross-reference | Cruce de Referencia**

Goodyear 1R12-609

**Manufacturer | Fabricante**

Tuthill 704671-02

- 1/4-18 NPTF: max. 22 lb-ft
- 1/2-13 UNC: max. 35 lb-ft
- 3/4-16 UNF: max. 50 lb-ft

### 9 10-21 P 900

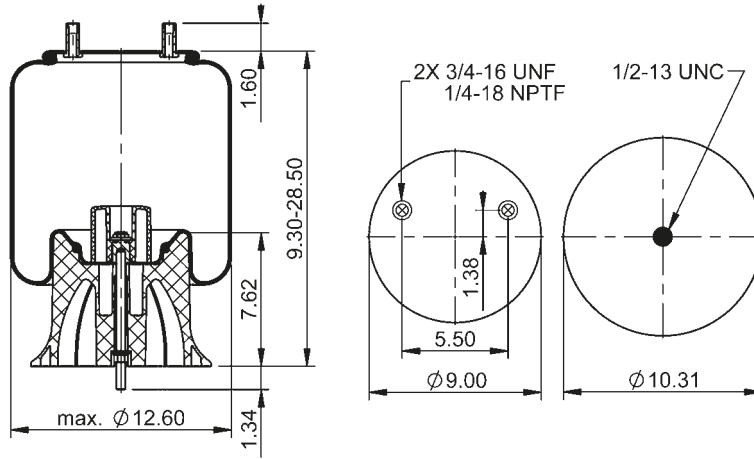

77809



**lb** 15.7 lb **No.** 9306248

**Manufacturer | Fabricante**  
SAF Holland 90557377

- 1/4-18 NPTF: max. 22 lb-ft
- 1/2-13 UNC: max. 35 lb-ft
- 3/4-16 UNF: max. 50 lb-ft

### 9 10-21 A 1187

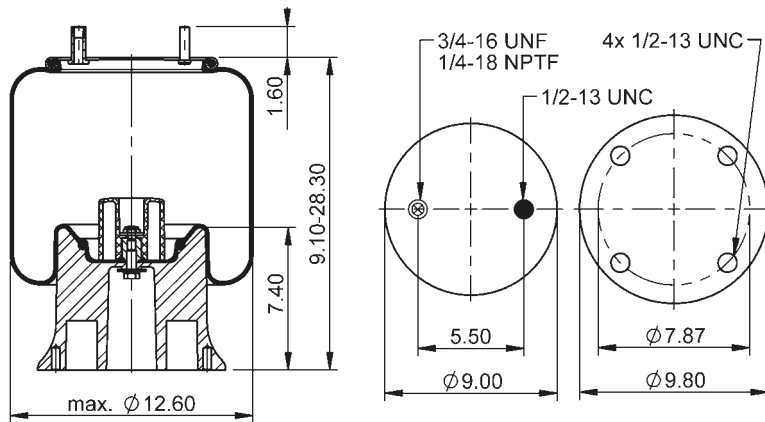

75221



**lb** 18.8 lb **No.** 9311399

**Cross-reference | Cruce de Referencia**  
Goodyear 1R12-653

- 1/4-18 NPTF: max. 22 lb-ft
- 1/2-13 UNC: max. 35 lb-ft
- 3/4-16 UNF: max. 50 lb-ft

### 9 10-21 A 1332 (BK)

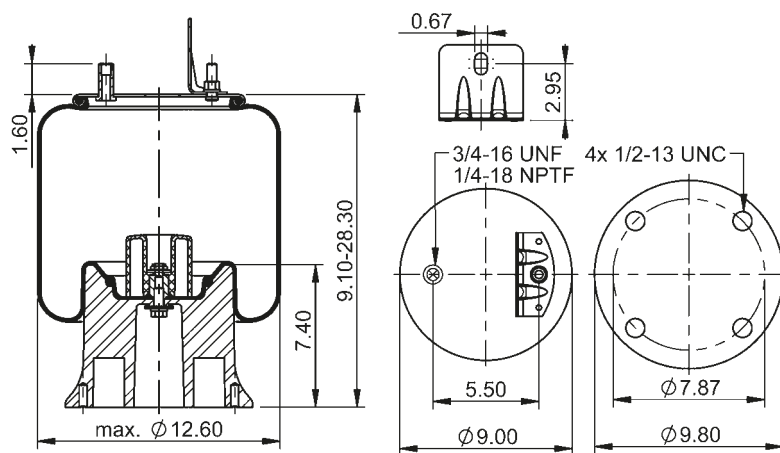

78074



**lb** 19.6 lb **No.** 9311399

**Cross-reference | Cruce de Referencia**  
Goodyear 1R12-444

- 1/4-18 NPTF: max. 22 lb-ft
- 1/2-13 UNC: max. 35 lb-ft
- 3/4-16 UNF: max. 50 lb-ft

### 9 10-21 P 1581

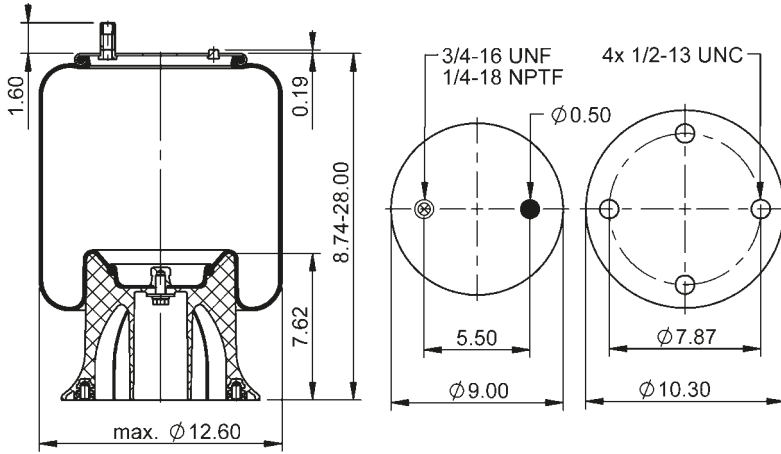

601035



**lb** 15.7 lb **No.** 9308129

**Cross-reference | Cruce de Referencia**  
Goodyear 1R12-599

- 1/4-18 NPTF: max. 22 lb-ft
- 1/2-13 UNC: max. 35 lb-ft
- 3/4-16 UNC: max. 50 lb-ft

### 9 10AS-21 P 1280

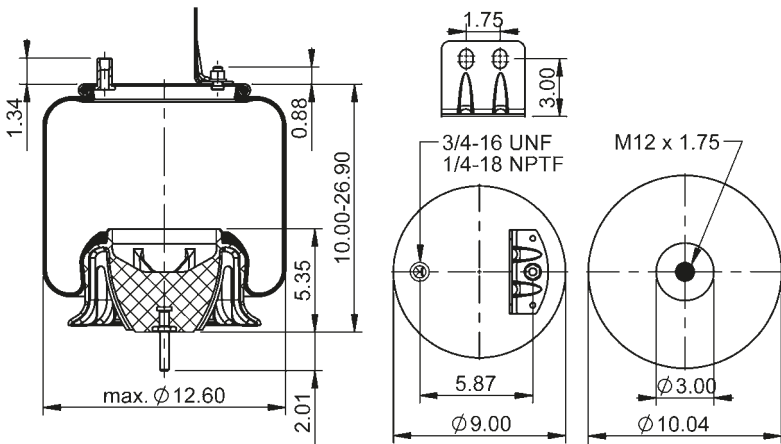

77093



**lb** 12.8 lb **No.** 9316239

**Cross-reference | Cruce de Referencia**  
Goodyear 1R12-507

**Manufacturer | Fabricante**  
International 3541734C1

- 1/4-18 NPTF: max. 22 lb-ft
- 3/4-16 UNF: max. 50 lb-ft

### 9 10D-21 A 324

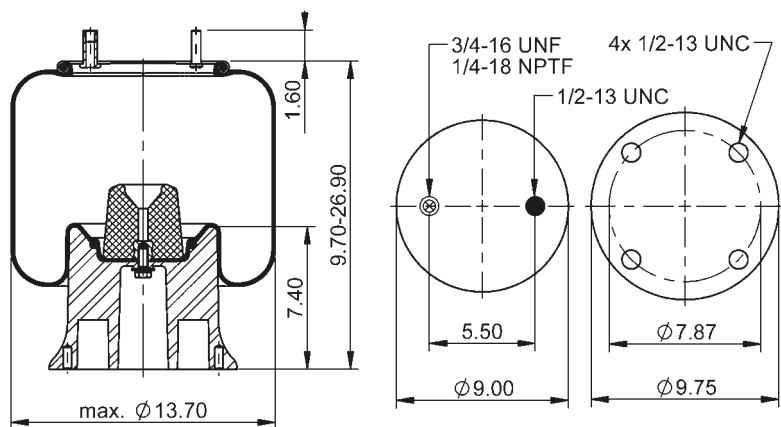

64375



**lb** 19.7 lb **No.** 9311399

**Cross-reference | Cruce de Referencia**  
Firestone W01-358-9250  
Goodyear 1R13-115

**Manufacturer | Fabricante**  
Granning 6427  
Ridewell 1003589250C  
SAF Holland 57009250  
Watson & Chalin AS-0096

- 1/4-18 NPTF: max. 22 lb-ft
- 1/2-13 UNC: max. 35 lb-ft
- 3/4-16 UNF: max. 50 lb-ft

### 9 10D-21 A 363

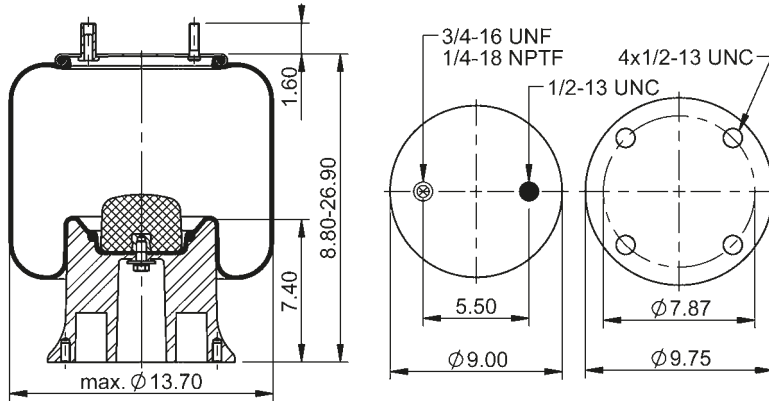

64376



**lb** 19.4 lb **No.** 9311399

**Cross-reference | Cruce de Referencia**  
 Firestone W01-358-9252  
 Goodyear 1R13-116

**Manufacturer | Fabricante**  
 Ridewell 1003589252C

1/4-18 NPTF: max. 22 lb-ft  
 1/2-13 UNC: max. 35 lb-ft  
 3/4-16 UNF: max. 50 lb-ft

### 9 10D-21 A 555

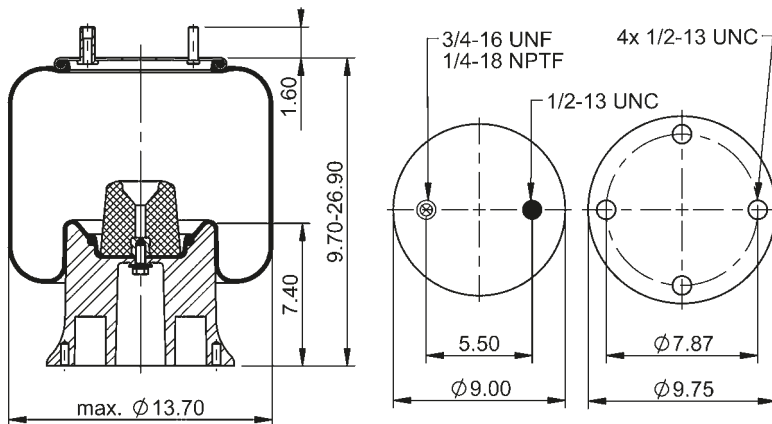

64377



**lb** 19.7 lb **No.** 9311399

**Cross-reference | Cruce de Referencia**  
 Firestone W01-358-9269

**Manufacturer | Fabricante**  
 Oshkosh RX-08-03

1/4-18 NPTF: max. 22 lb-ft  
 1/2-13 UNC: max. 35 lb-ft  
 3/4-16 UNF: max. 50 lb-ft

### 9 10BP-22 P 739

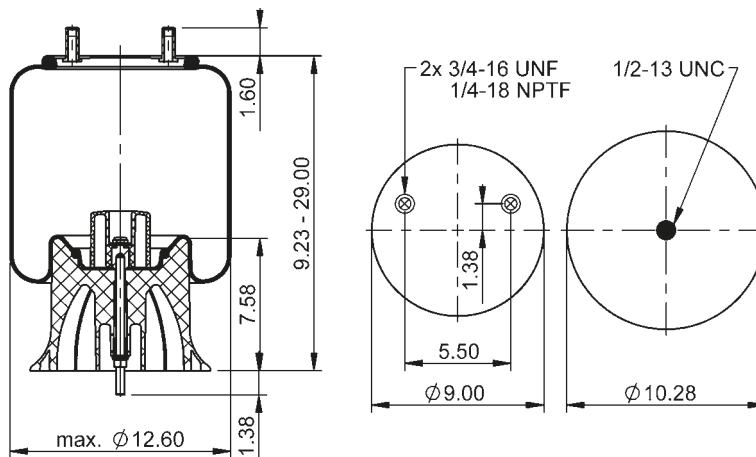

64695



**lb** 16.2 lb **No.** 9306248

**Cross-reference | Cruce de Referencia**  
 Firestone W01-358-9645

**Manufacturer | Fabricante**  
 Hendrickson S-23612

1/4-18 NPTF: max. 22 lb-ft  
 1/2-13 UNC: max. 35 lb-ft  
 3/4-16 UNF: max. 50 lb-ft

### 10 10A-12 P 1330

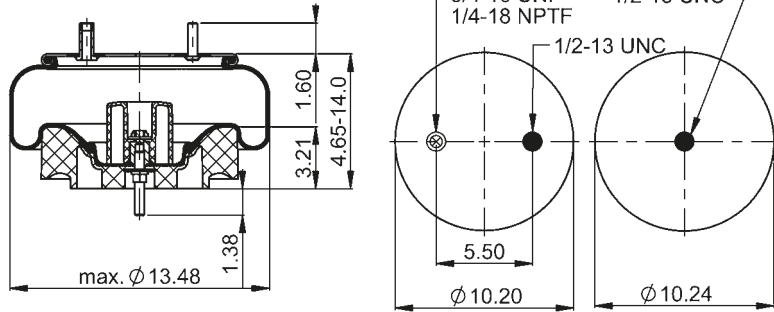

77963



**lb** 12.7 lb **No.** 9317517

**Cross-reference | Cruce de Referencia**

Firestone W01-358-8729  
Goodyear 1R13-130

**Manufacturer | Fabricante**

Meritor 202796  
A2258F1410  
A2258E1461  
Connect Air Springs 198729  
Suspensions, Inc. 202796

1/4-18 NPTF: max. 22 lb-ft  
1/2-13 UNC: max. 35 lb-ft  
3/4-16 UNF: max. 50 lb-ft

### 10 10-13 S 1614

**new**

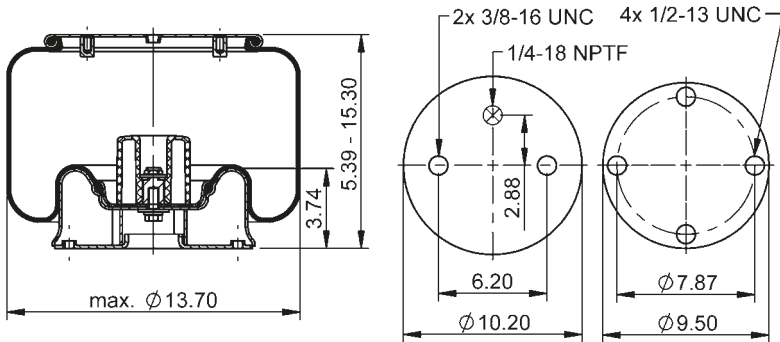

601634



**lb** 19.0 lb **No.** 9311827

**Cross-reference | Cruce de Referencia**

Firestone W01-358-8636

**Manufacturer | Fabricante**

Tuthill 705951-01

1/4-18 NPTF: max. 22 lb-ft  
3/8-16 UNC: max. 18 lb-ft

### 10 10K-13 P 163

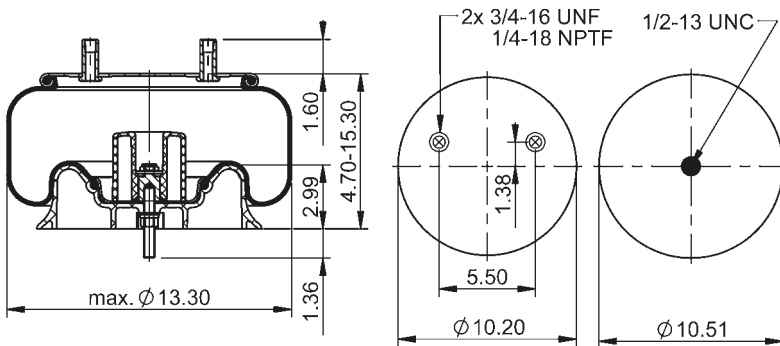

78164



**lb** 12.1 lb **No.** 9313619

**Manufacturer | Fabricante**

SAF Holland 90557397

1/4-18 NPTF: max. 22 lb-ft  
1/2-13 UNC: max. 35 lb-ft  
3/4-16 UNF: max. 50 lb-ft



### 10 10K-13 S 1025

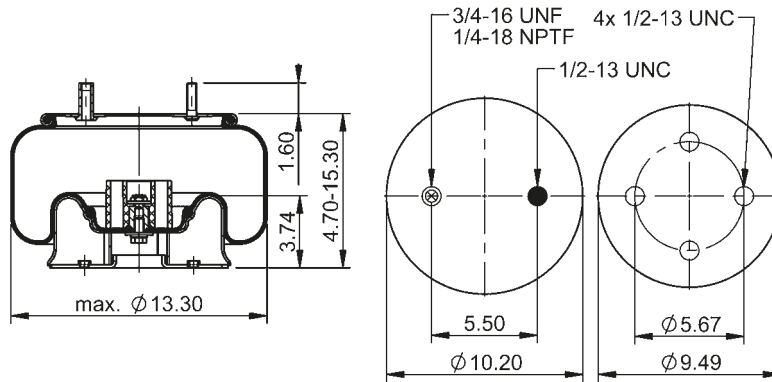

73071



**lb** 19.1 lb **No.** 9309758

**Manufacturer | Fabricante**  
Granning 712151-01  
Tuthill

1/4-18 NPTF: max. 22 lb-ft  
1/2-13 UNC: max. 35 lb-ft  
3/4-16 UNF: max. 50 lb-ft

### 10 10U-13 P 189

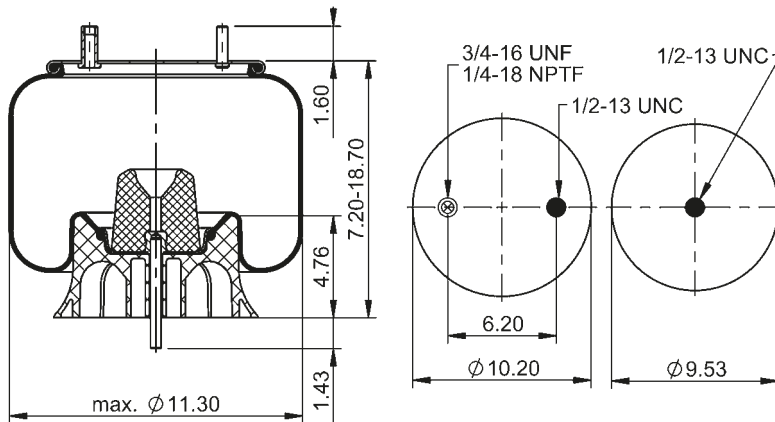

69494



**lb** 15.0 lb **No.** 9308128

**Cross-reference | Cruce de Referencia**  
Firestone W01-W35-8739

**Manufacturer | Fabricante**  
New Flyer 201313  
201316

1/4-18 NPTF: max. 22 lb-ft  
1/2-13 UNC: max. 35 lb-ft  
3/4-16 UNF: max. 50 lb-ft

### 10 10-14 S 736

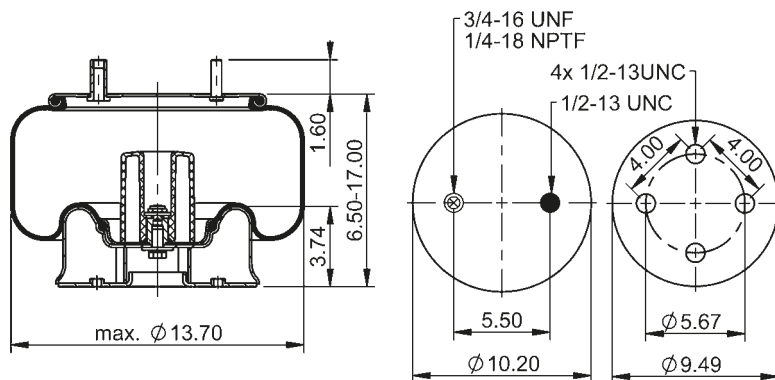

64625



**lb** 20.3 lb **No.** 9309758

**Manufacturer | Fabricante**  
Granning 700195-01  
Reyco

1/4-18 NPTF: max. 22 lb-ft  
1/2-13 UNC: max. 35 lb-ft  
3/4-16 UNF: max. 50 lb-ft

### 10 10B-14 P 165

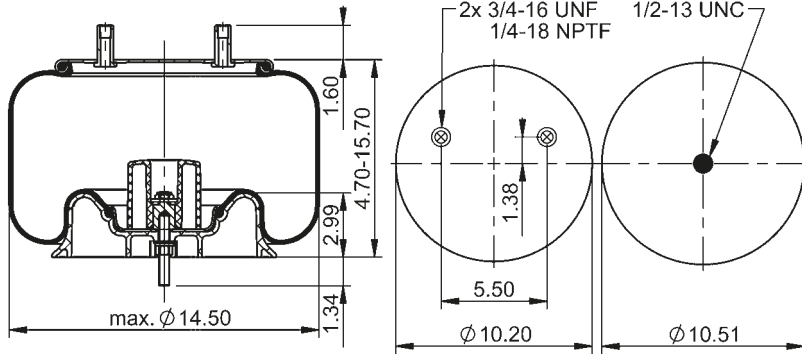

78314



**lb** 12.1 lb **No.** 9313619

**Manufacturer | Fabricante**  
SAF Holland 90557400

- 1/4-18 NPTF: max. 22 lb-ft
- 1/2-13 UNC: max. 35 lb-ft
- 3/4-16 UNF: max. 50 lb-ft

### 10 10BS-14 S 1124

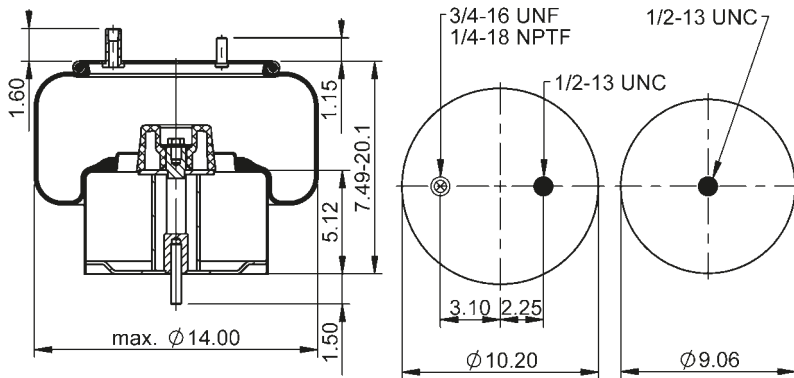

78244



**lb** 22.0 lb **No.** 9317376

**Manufacturer | Fabricante**  
Hendrickson 13677

- 1/4-18 NPTF: max. 22 lb-ft
- 1/2-13 UNC: max. 35 lb-ft
- 3/4-16 UNF: max. 50 lb-ft

### 10 10K-14 P 167

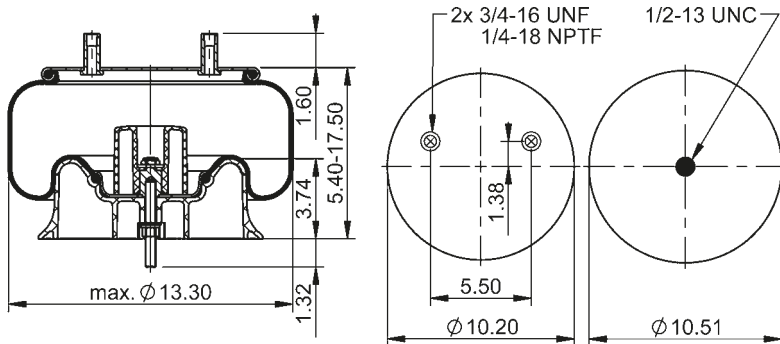

78316



**lb** 12.8 lb **No.** 9313630

**Manufacturer | Fabricante**  
SAF Holland 90557398

- 1/4-18 NPTF: max. 22 lb-ft
- 1/2-13 UNC: max. 35 lb-ft
- 3/4-16 UNF: max. 50 lb-ft

### 10 10K-14 S 1022

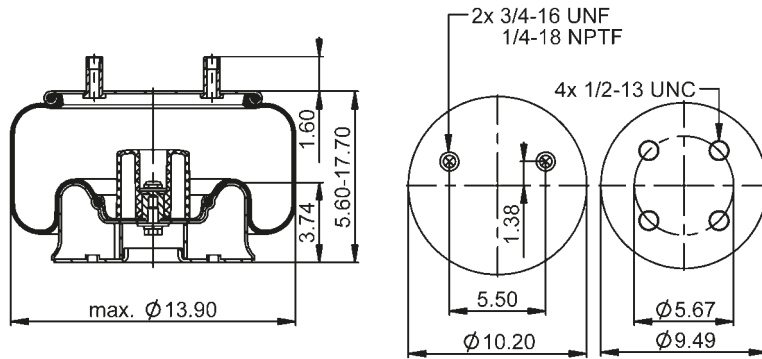

78231



**lb** 19.4 lb **No.** 9309758

**Manufacturer | Fabricante**  
Hendrickson C-33247

- 1/4-18 NPTF: max. 22 lb-ft
- 1/2-13 UNC: max. 35 lb-ft
- 3/4-16 UNF: max. 50 lb-ft

### 10 10K-14 S 1024

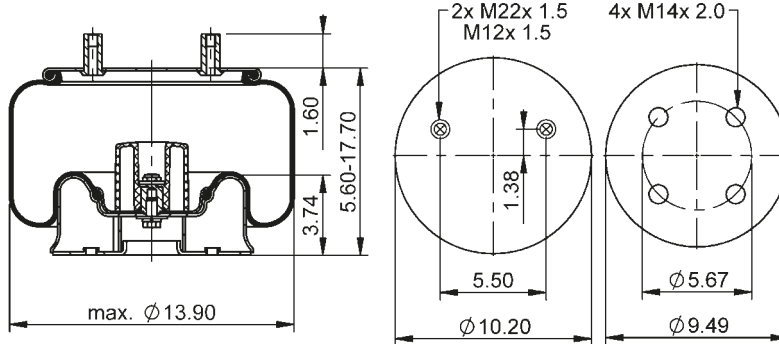

78241



**lb** 19.0 lb **No.** 9315841

**Manufacturer | Fabricante**  
Hendrickson C-33001

- M12x1.5: max. 22 lb-ft
- M22x1.5: max. 50 lb-ft

### 10 100-14 P 838

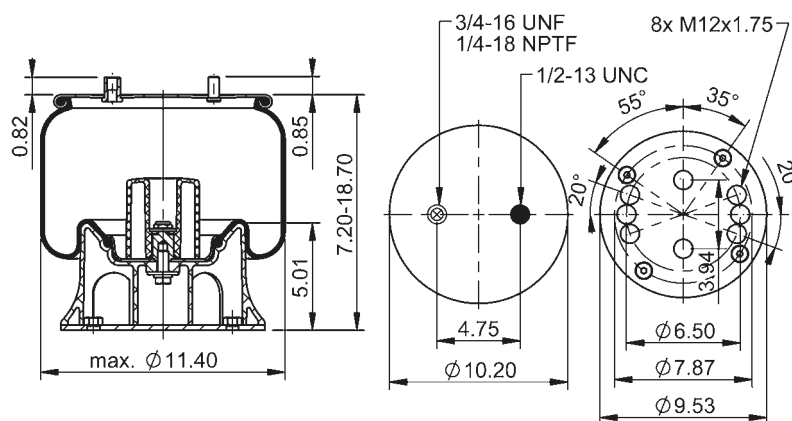

66325



**lb** 18.0 lb **No.** 9308301

- 1/4-18 NPTF: max. 22 lb-ft
- 1/2-13 UNC: max. 35 lb-ft

### 10 10S-14 S 1095 (BK)

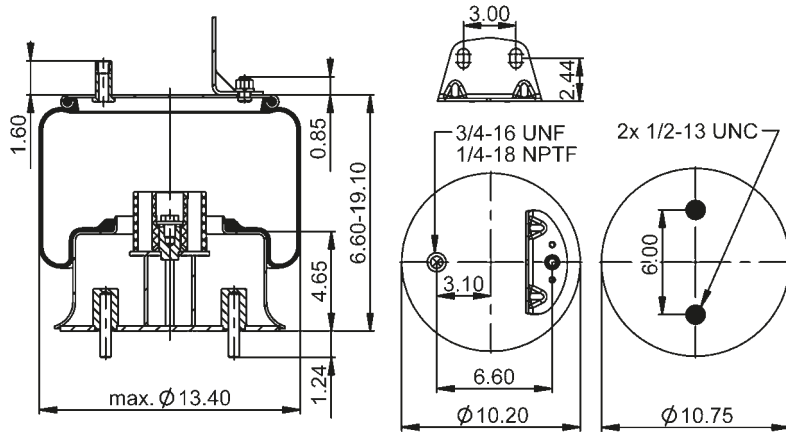

78248



**lb** 25.8 lb **No.** 9317350

**Manufacturer | Fabricante**  
Hendrickson 77619-000

**1/4-18 NPTF:** max. 22 lb-ft  
**1/2-13 UNC:** max. 35 lb-ft  
**3/4-16 UNF:** max. 50 lb-ft

### 10 10-15 P 453

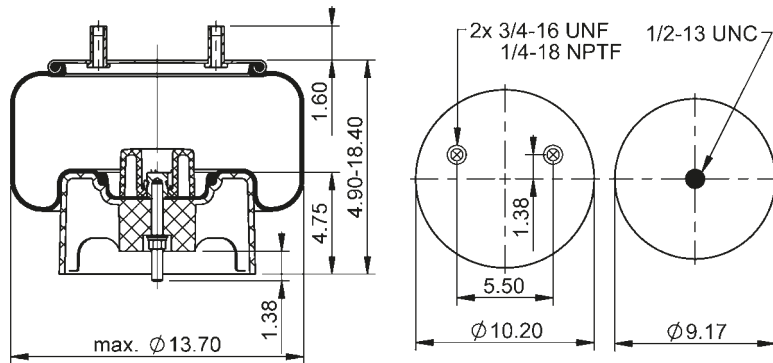

64624



**lb** 13.3 lb **No.** 9310704

**Cross-reference | Cruce de Referencia**  
Firestone W01-358-8751

**Manufacturer | Fabricante**  
Hendrickson S-20900

**1/4-18 NPTF:** max. 22 lb-ft  
**1/2-13 UNC:** max. 35 lb-ft  
**3/4-16 UNF:** max. 50 lb-ft

### 10 10-15 S 518

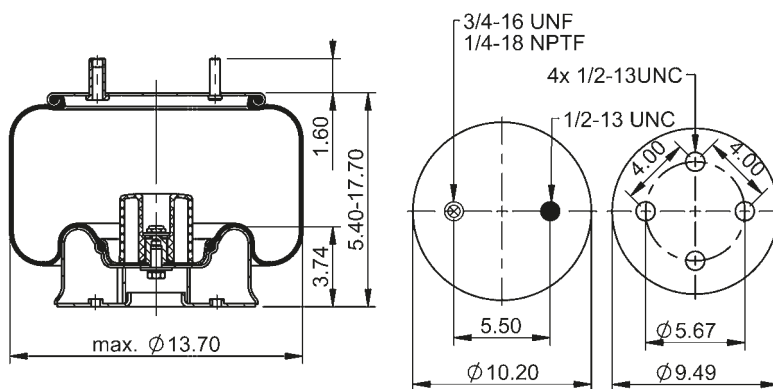

64396



**lb** 19.4 lb **No.** 9309758

**Cross-reference | Cruce de Referencia**  
Firestone W01-358-8752  
Goodyear 1R13-138

**Manufacturer | Fabricante**  
Ridewell 1003588752C  
Seats 201642  
Suspensions, Inc.  
Watson & Chalin AS-0094

**1/4-18 NPTF:** max. 22 lb-ft  
**1/2-13 UNC:** max. 35 lb-ft  
**3/4-16 UNF:** max. 50 lb-ft

### 10 10-15 P 522

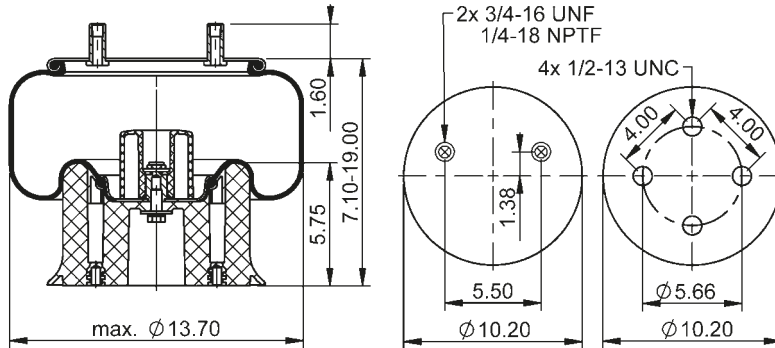

64397



**lb** 21.9 lb **No.** 9317377

**Cross-reference | Cruce de Referencia**

Firestone W01-358-8755  
Goodyear 1R13-124

**Manufacturer | Fabricante**

Hendrickson S-21623  
S-22045

- 1/4-18 NPTF: max. 22 lb-ft
- 1/2-13 UNC: max. 35 lb-ft
- 3/4-16 UNF: max. 50 lb-ft

### 10 10-15 P 711

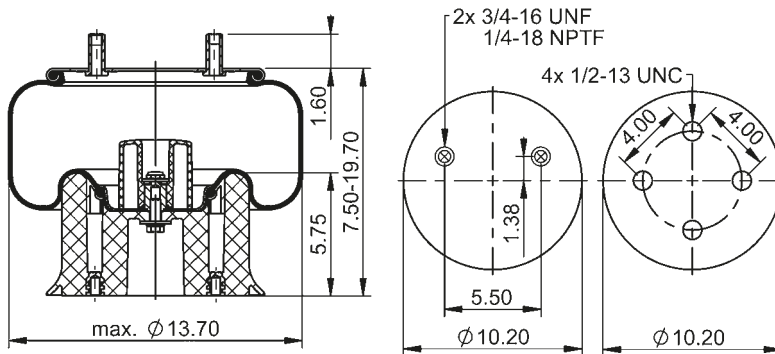

64635



**lb** 22.0 lb **No.** 9317377

**Cross-reference | Cruce de Referencia**

Firestone W01-358-8710  
Goodyear 1R13-124

**Manufacturer | Fabricante**

Hendrickson C-21624  
S-22046

- 1/4-18 NPTF: max. 22 lb-ft
- 1/2-13 UNC: max. 35 lb-ft
- 3/4-16 UNF: max. 50 lb-ft

### 10 10-15 S 713

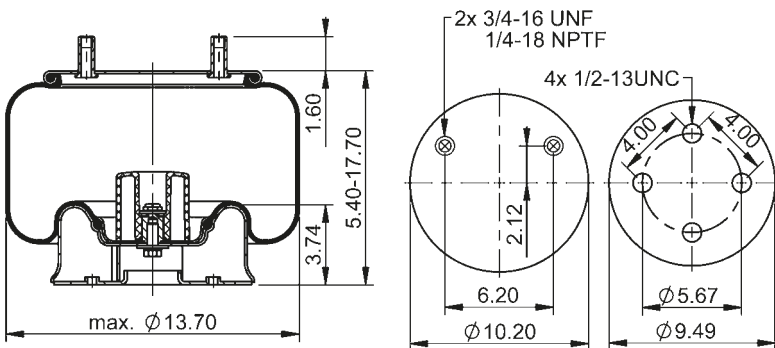

64639



**lb** 19.6 lb **No.** 9309758

**Cross-reference | Cruce de Referencia**

Firestone W01-358-8753  
Goodyear 1R13-207

**Manufacturer | Fabricante**

Ridwell 1003588753C  
Spring Valley AS-8713  
Watson & Chalin AS-0098

- 1/4-18 NPTF: max. 22 lb-ft
- 1/2-13 UNC: max. 35 lb-ft
- 3/4-16 UNF: max. 50 lb-ft

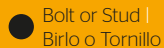

Bolt or Stud | Birlo o Tornillo



Hole | Tuerca Ciega



Combination Stud | Combinación de Entrada de Aire y Birlo



Air Inlet | Entrada de Aire



Stud and Nut | Birlo y Tuerca

### 10 10-15 S 773

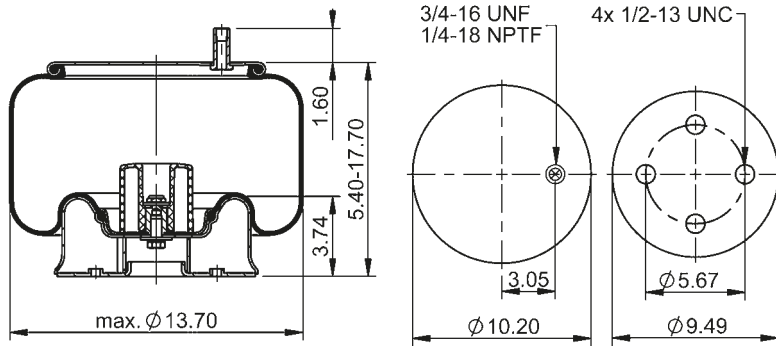

64725



**lb** 19.5 lb **No.** 9309758

**Cross-reference | Cruce de Referencia**

Firestone W01-358-8740  
Goodyear 1R13-210

**Manufacturer | Fabricante**

Reyco 23433-01

- 1/4-18 NPTF: max. 22 lbft
- 1/2-13 UNC: max. 35 lbft
- 3/4-16 UNF: max. 50 lbft

### 10 10-15 S 871

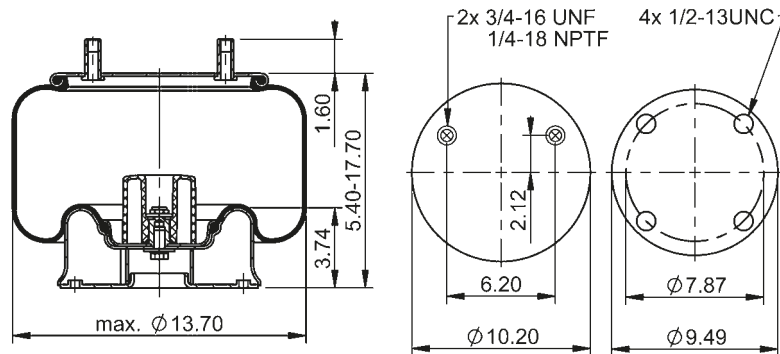

66340



**lb** 19.6 lb **No.** 9311827

**Cross-reference | Cruce de Referencia**

Firestone W01-358-8782  
Goodyear 1R13-109

**Manufacturer | Fabricante**

Ridewell 1001R13109G  
1003588782C

- 1/4-18 NPTF: max. 22 lbft
- 1/2-13 UNC: max. 35 lbft
- 3/4-16 UNF: max. 50 lbft

### 10 10-15 S 962

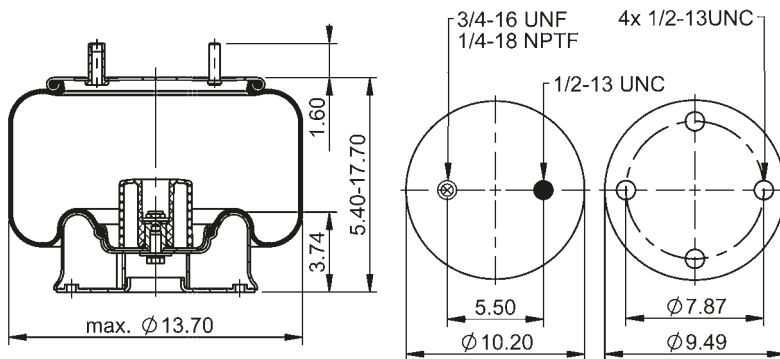

67600



**lb** 19.6 lb **No.** 9311827

**Cross-reference | Cruce de Referencia**

Firestone W01-358-8723  
Goodyear 1R13-097  
1R13-087

**Manufacturer | Fabricante**

Hendrickson 698132  
Ridewell 1001R13-087  
1001R13-097

- 1/4-18 NPTF: max. 22 lbft
- 1/2-13 UNC: max. 35 lbft
- 3/4-16 UNF: max. 50 lbft

### 10 10-15 S 1015

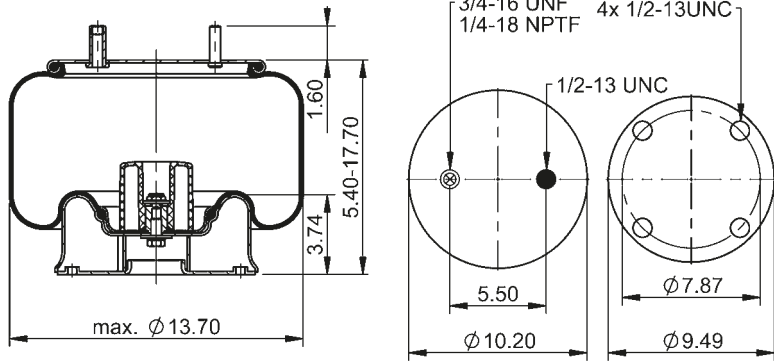

72729



**lb** 19.5 lb **No.** 9311827

**Cross-reference | Cruce de Referencia**

Goodyear 1R13-075

- 1/4-18 NPTF: max. 22 lb-ft
- 1/2-13 UNC: max. 35 lb-ft
- 3/4-16 UNF: max. 50 lb-ft

### 10 10-15 P 1140

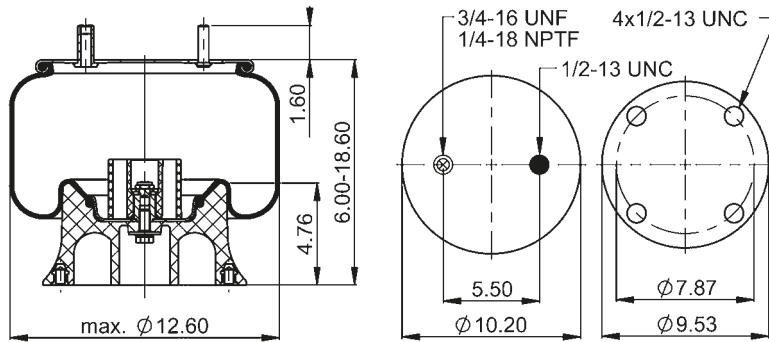

74765



**lb** 12.9 lb **No.** 9308301

**Cross-reference | Cruce de Referencia**

Firestone W01-W35-8754  
Goodyear 1R13-053

**Manufacturer | Fabricante**

New Flyer 13

- 1/4-18 NPTF: max. 22 lb-ft
- 1/2-13 UNC: max. 35 lb-ft
- 3/4-16 UNF: max. 50 lb-ft

### 10 10B-15 P 166

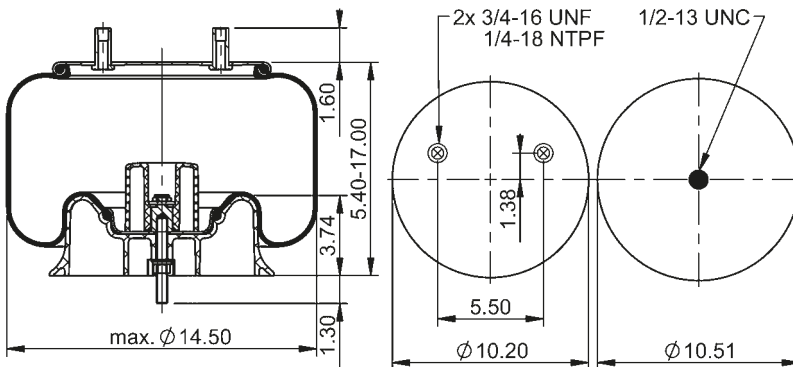

78315



**lb** 12.8 lb **No.** 9313630

**Manufacturer | Fabricante**

SAF Holland 90557401

- 1/4-18 NPTF: max. 22 lb-ft
- 1/2-13 UNC: max. 35 lb-ft
- 3/4-16 UNF: max. 50 lb-ft

### 10 10K-15 P 164

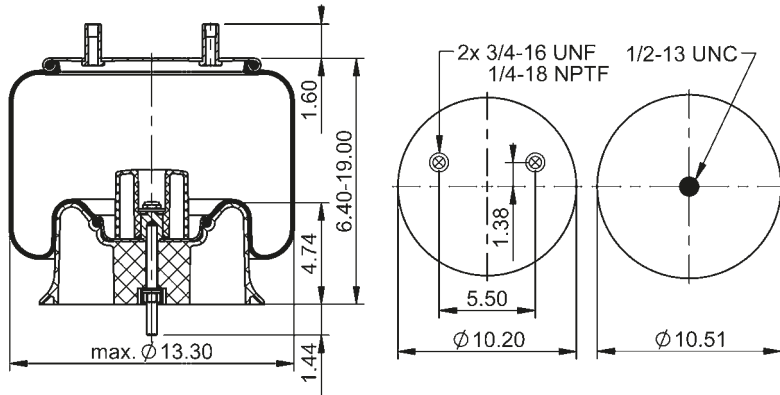

78317



**lb** 13.7 lb **No.** 9313631

**Manufacturer | Fabricante**  
SAF Holland 90557399

**1/4-18 NPTF:** max. 22 lb-ft  
**1/2-13 UNC:** max. 35 lb-ft  
**3/4-16 UNF:** max. 50 lb-ft

### 10 10K-15 P 1033

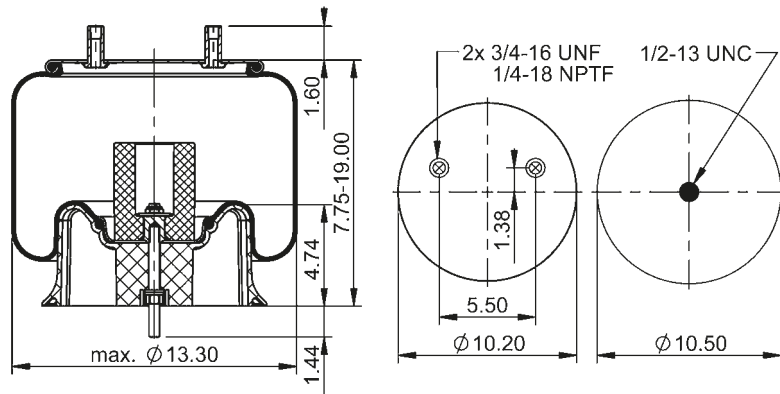

78318



**lb** 14.3 lb **No.** 9313631

**Manufacturer | Fabricante**  
SAF Holland 90557458

**1/4-18 NPTF:** max. 22 lb-ft  
**1/2-13 UNC:** max. 35 lb-ft  
**3/4-16 UNF:** max. 50 lb-ft

### 10 10K-15 P 1034

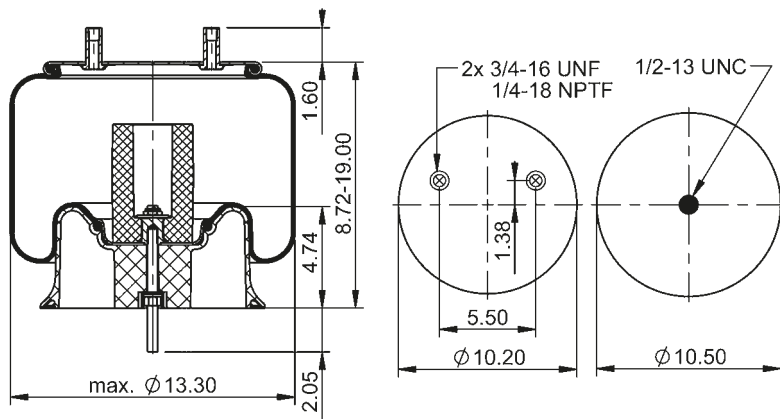

78319



**lb** 14.3 lb **No.** 9313631

**Manufacturer | Fabricante**  
SAF Holland 90557459

**1/4-18 NPTF:** max. 22 lb-ft  
**1/2-13 UNC:** max. 35 lb-ft  
**3/4-16 UNF:** max. 50 lb-ft



### 10 10K-15 P 1035

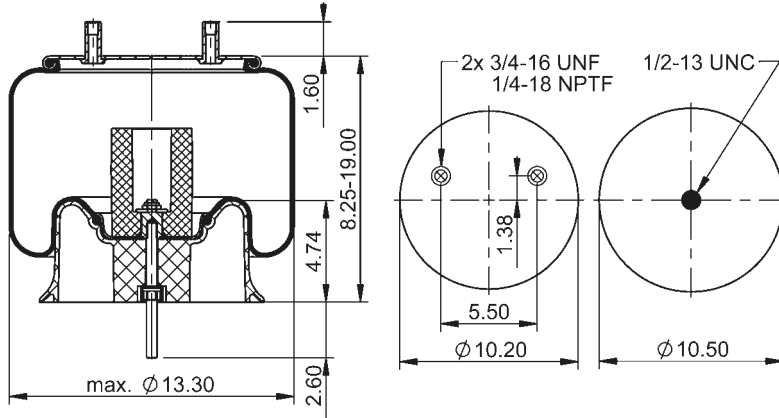

78330



**lb** 14.3 lb **No.** 9313631

**Manufacturer | Fabricante**  
SAF Holland 90557460

**1/4-18 NPTF:** max. 22 lbft  
**1/2-13 UNC:** max. 35 lbft  
**3/4-16 UNF:** max. 50 lbft

### 10 10-16 P 526

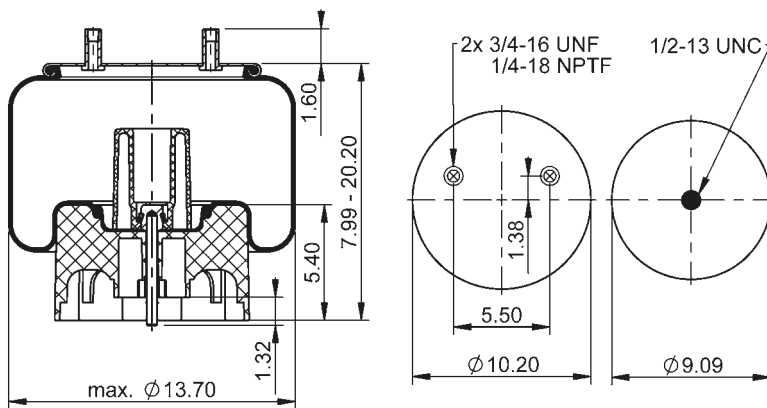

64638



**lb** 22.3 lb **No.** 9315733

**Cross-reference | Cruce de Referencia**  
Firestone W01-358-8708  
Goodyear 1R13-177

**Manufacturer | Fabricante**  
Hendrickson S-21966  
Navistar/Fleetrite 1R13-250

**1/4-18 NPTF:** max. 22 lbft  
**1/2-13 UNC:** max. 35 lbft  
**3/4-16 UNF:** max. 50 lbft

### 10 10-16 P 533

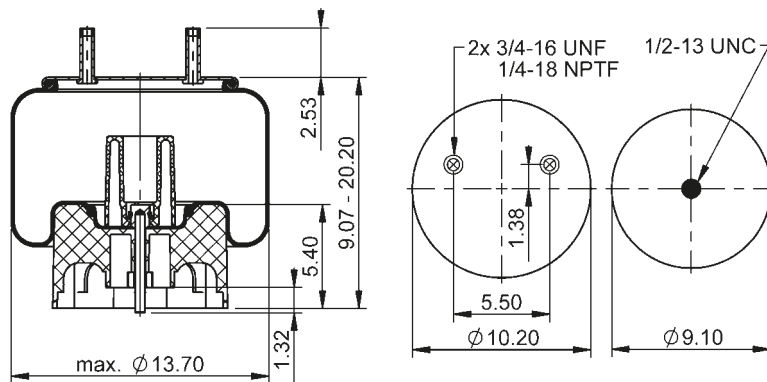

64636



**lb** 22.3 lb **No.** 9315733

**Cross-reference | Cruce de Referencia**  
Firestone W01-358-8713  
Goodyear 1R13-176

**Manufacturer | Fabricante**  
Hendrickson S-22948

**1/4-18 NPTF:** max. 22 lbft  
**1/2-13 UNC:** max. 35 lbft  
**3/4-16 UNF:** max. 50 lbft

### 10 10-16 S 724

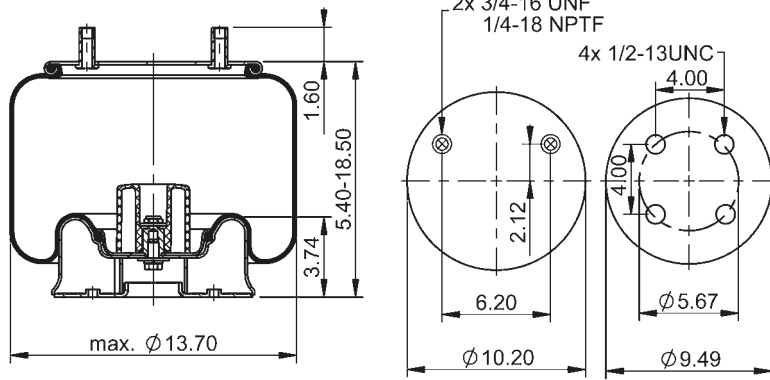

64649



**lb** 19.8 lb **No.** 9309758

**Cross-reference | Cruce de Referencia**  
 Firestone W01-358-8637  
 Goodyear 1R13-155

**Manufacturer | Fabricante**  
 Watson & Chalin AS-0107-G

- 1/4-18 NPTF: max. 22 lb-ft
- 1/2-13 UNC: max. 35 lb-ft
- 3/4-16 UNF: max. 50 lb-ft

### 10 10-16 S 1239

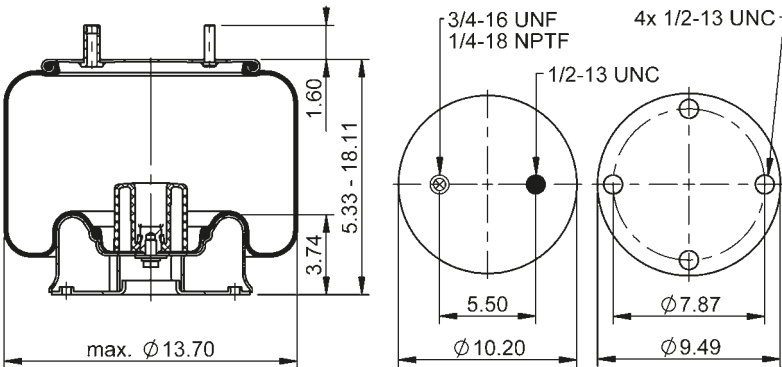

75972



**lb** 19.6 lb **No.** 9311827

**Cross-reference | Cruce de Referencia**  
 Goodyear 1R13-181

**Manufacturer | Fabricante**  
 Ridewell 1001R13181G

- 1/4-18 NPTF: max. 22 lb-ft
- 1/2-13 UNC: max. 25 lb-ft
- 3/4-16 UNF: max. 50 lb-ft

### 10 10A-16 P 1102

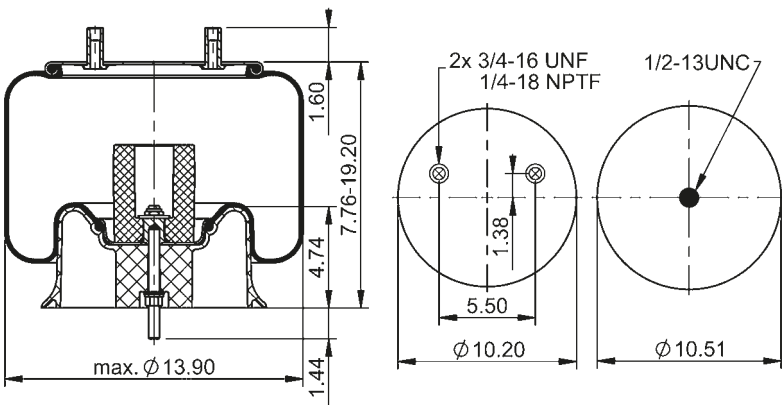

78313



**lb** 14.1 lb **No.** 9313631

**Manufacturer | Fabricante**  
 SAF Holland 90557433

- 1/4-18 NPTF: max. 22 lb-ft
- 1/2-13 UNC: max. 35 lb-ft
- 3/4-16 UNF: max. 50 lb-ft

### 10 10A-16 P 1105

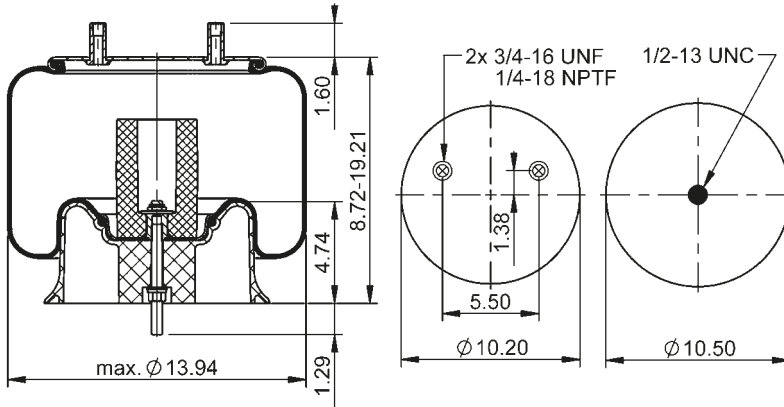

78312



**lb** 14.3 lb **No.** 9313631

**Manufacturer | Fabricante**  
SAF Holland 90557432

**1/4-18 NPTF:** max. 22 lbft  
**1/2-13 UNC:** max. 35 lbft  
**3/4-16 UNF:** max. 50 lbft

### 10 10A-16 P 1106

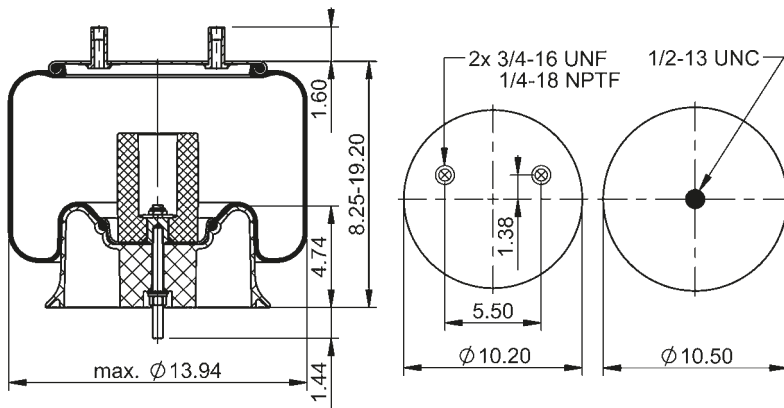

78311



**lb** 14.2 lb **No.** 9313631

**Manufacturer | Fabricante**  
SAF Holland 90557431  
90557455

**1/4-18 NPTF:** max. 22 lbft  
**1/2-13 UNC:** max. 35 lbft  
**3/4-16 UNF:** max. 50 lbft

### 10 10B-16 P 162

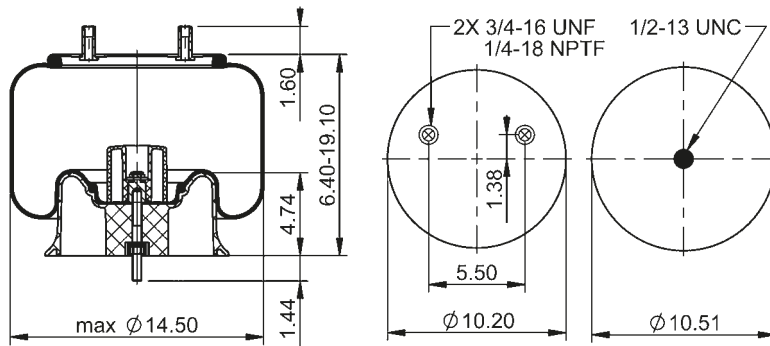

78163



**lb** 13.4 lb **No.** 9313631

**Manufacturer | Fabricante**  
SAF Holland 90557402

**1/4-18 NPTF:** max. 22 lbft  
**1/2-13 UNC:** max. 35 lbft  
**3/4-16 UNF:** max. 50 lbft

### 10 10-16.5 S 262

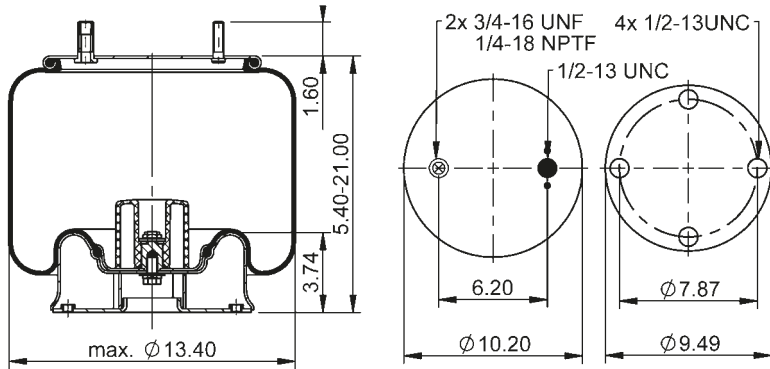

70010



**lb** 19.4 lb **No.** 9311827

**Cross-reference | Cruce de Referencia**  
Firestone W01-358-8735

**Manufacturer | Fabricante**  
Granning 7901  
700029-01

1/4-18 NPTF: max. 22 lb-ft  
1/2-13 UNC: max. 35 lb-ft  
3/4-16 UNF: max. 50 lb-ft

### 10 10-16.5 S 783

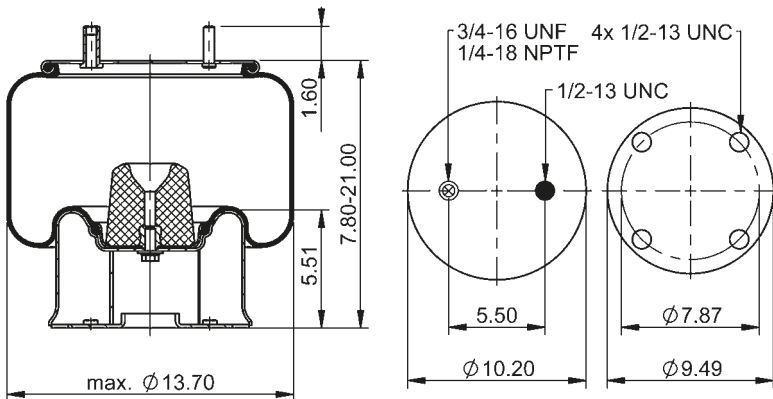

64746



**lb** 23.4 lb **No.** 9312770

**Cross-reference | Cruce de Referencia**  
Goodyear 1R13-039

**Manufacturer | Fabricante**  
Watson & Chalin AS-0013

1/4-18 NPTF: max. 22 lb-ft  
1/2-13 UNC: max. 35 lb-ft  
3/4-16 UNF: max. 50 lb-ft

### 10 10-16.5 S 854

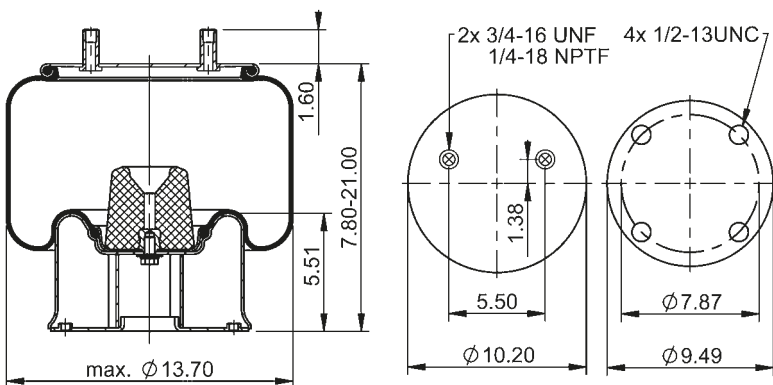

66083



**lb** 23.1 lb **No.** 9312770

**Manufacturer | Fabricante**  
Watson & Chalin AS-0219

1/4-18 NPTF: max. 18 lb-ft  
1/2-13 UNC: max. 35 lb-ft  
3/4-16 UNF: max. 50 lb-ft

### 10 10K-20 P 1059

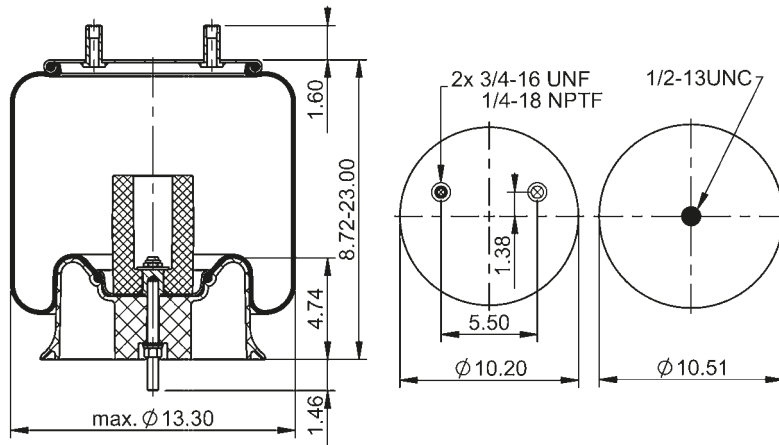

78332



**lb** 17.0 lb **No.** 9313631

**Manufacturer | Fabricante**  
SAF Holland 90557461

**1/4-18 NPTF:** max. 22 lb-ft  
**1/2-13 UNC:** max. 35 lb-ft  
**3/4-16 UNF:** max. 50 lb-ft

### 10 10K-20 P 1114

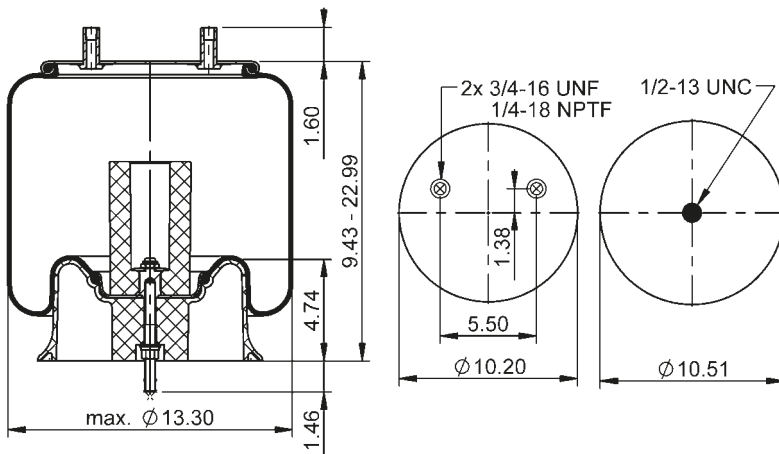

78331



**lb** 15.3 lb **No.** 9313631

**Manufacturer | Fabricante**  
SAF Holland 90557430

**1/4-18 NPTF:** max. 22 lb-ft  
**1/2-13 UNC:** max. 35 lb-ft  
**3/4-16 UNF:** max. 50 lb-ft

### 10 10-21 P 015

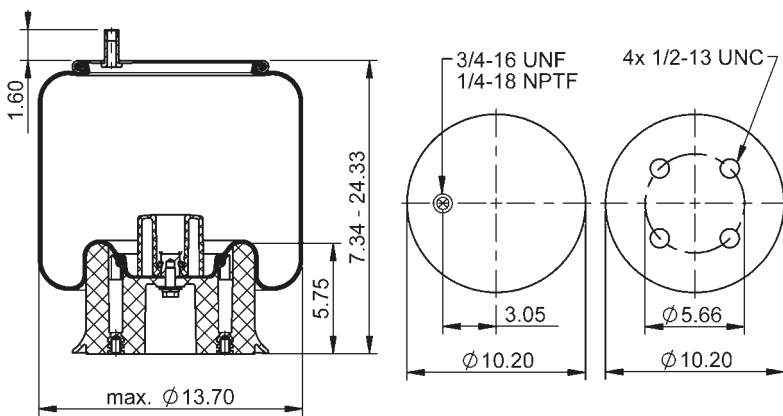

67951



**lb** 15.2 lb **No.** 9317377

**Cross-reference | Cruce de Referencia**  
Firestone W01-358-9581

**Manufacturer | Fabricante**  
Hendrickson S-20414

**1/4-18 NPTF:** max. 22 lb-ft  
**1/2-13 UNC:** max. 35 lb-ft  
**3/4-16 UNF:** max. 50 lb-ft

### 10 10-21 P 299

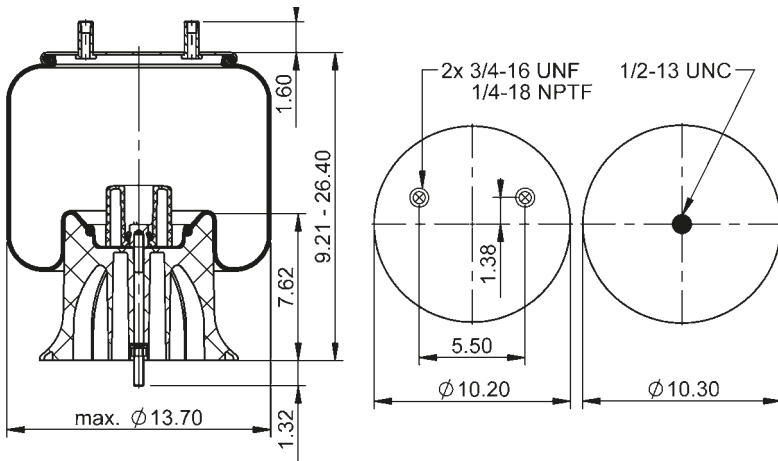

78162



**lb** 15.7 lb **No.** 9306248

**Manufacturer | Fabricante**  
SAF Holland 90557416

**1/4-18 NPTF:** max. 22 lb-ft  
**1/2-13 UNC:** max. 35 lb-ft  
**3/4-16 UNF:** max. 50 lb-ft

### 10 10-21 P 434

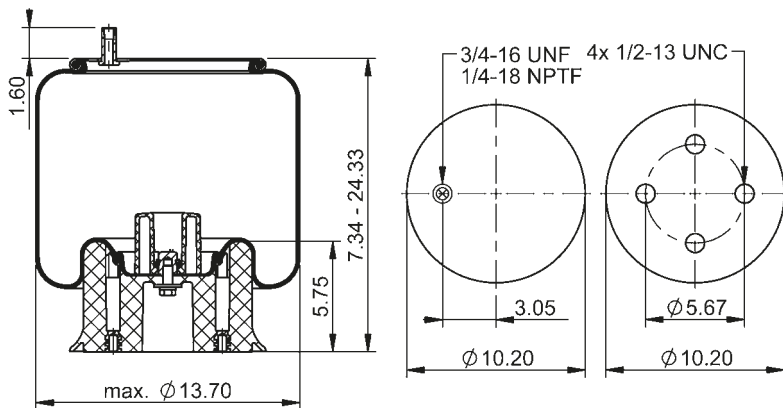

64394



**lb** 15.1 lb **No.** 9317377

**Cross-reference | Cruce de Referencia**  
Firestone W01-358-9580  
Goodyear 1R13-118  
1R13-149

**Manufacturer | Fabricante**  
Hendrickson S-20127  
Loadguard SC2761  
Navistar/Fleetrite 1R13-247

**1/4-18 NPTF:** max. 22 lb-ft  
**1/2-13 UNC:** max. 35 lb-ft  
**3/4-16 UNF:** max. 50 lb-ft

### 10 10-21 P 486

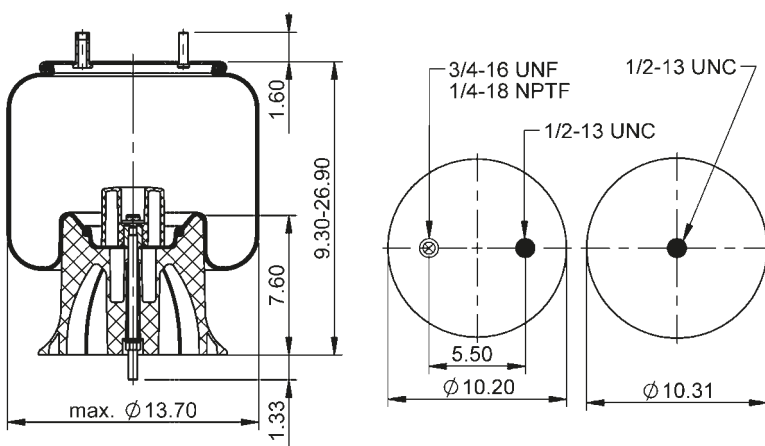

64419



**lb** 16.5 lb **No.** 9306248

**Cross-reference | Cruce de Referencia**  
Firestone W01-358-8749  
Goodyear 1R13-153

**Manufacturer | Fabricante**  
SAF Holland 90557168  
90557289  
Watson & Chalin AS-0175

**1/4-18 NPTF:** max. 22 lb-ft  
**1/2-13 UNC:** max. 35 lb-ft  
**3/4-16 UNF:** max. 50 lb-ft

### 10 10-21 P 570

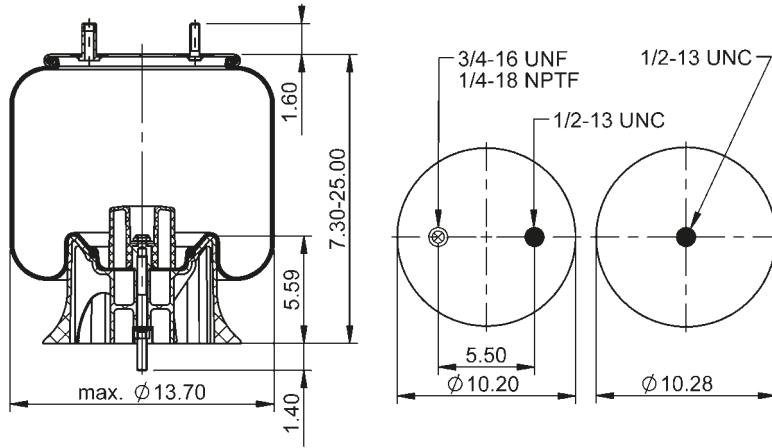

64252



**lb** 14.5 lb **No.** 9314552

**Cross-reference | Cruce de Referencia**  
 Firestone W01-358-8748  
 Goodyear 1R13-152

**Manufacturer | Fabricante**  
 SAF Holland 90557167  
 90557288

1/4-18 NPTF: max. 22 lb-ft  
 1/2-13 UNC: max. 35 lb-ft  
 3/4-16 UNF: max. 50 lb-ft

### 10 10-21 P 774

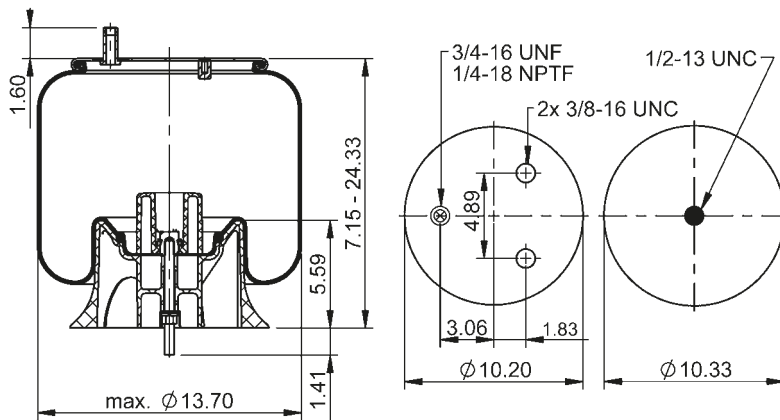

64728



**lb** 14.8 lb **No.** 9314552

**Cross-reference | Cruce de Referencia**  
 Firestone W01-358-8746  
 Goodyear 1R13-208

**Manufacturer | Fabricante**  
 SAF Holland 90557235

1/4-18 NPTF: max. 22 lb-ft  
 3/8-16 UNC: max. 20 lb-ft  
 1/2-13 UNC: max. 35 lb-ft

### 10 10-21 P 949

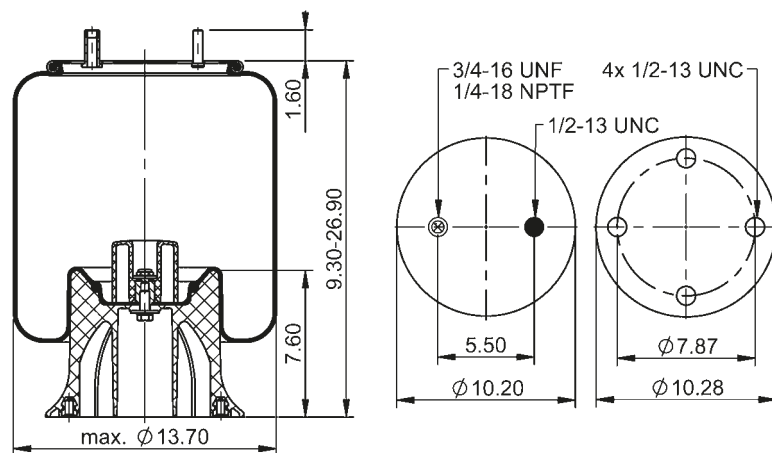

67507



**lb** 16.4 lb **No.** 9308129

**Manufacturer | Fabricante**  
 SAF Holland 90557370

1/4-18 NPTF: max. 22 lb-ft  
 1/2-13 UNC: max. 35 lb-ft  
 3/4-16 UNF: max. 50 lb-ft

### 10 10-21 P 964

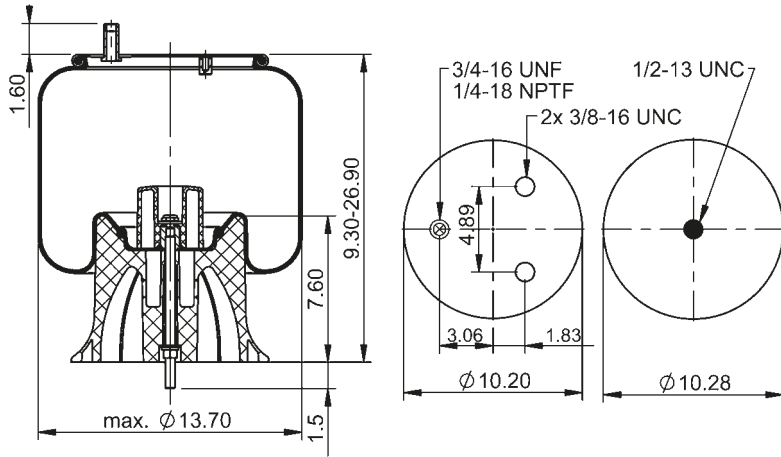

67624



**lb** 15.7 lb **No.** 9306248

**Cross-reference | Cruce de Referencia**  
Firestone W01-358-8744

**Manufacturer | Fabricante**  
SAF Holland 90557243

- 1/4-18 NPTF: max. 22 lb-ft
- 3/8-16 UNC: max. 20 lb-ft
- 1/2-13 UNC: max. 35 lb-ft

### 10 10-21 P 1000

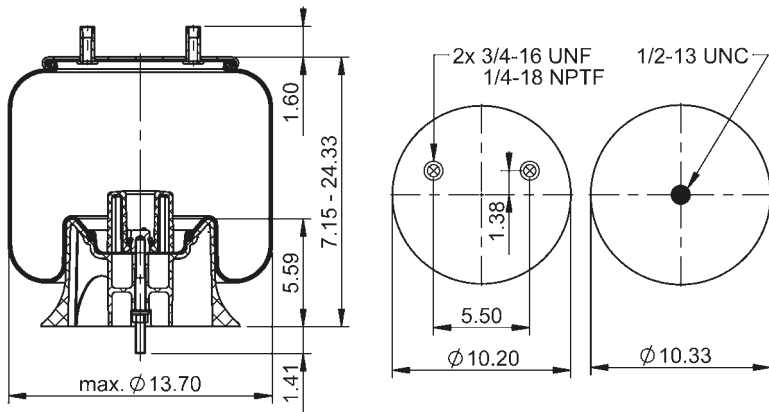

78161



**lb** 14.2 lb **No.** 9314552

**Manufacturer | Fabricante**  
SAF Holland 90557415

- 1/4-18 NPTF: max. 22 lb-ft
- 1/2-13 UNC: max. 35 lb-ft
- 3/4-16 UNF: max. 50 lb-ft

### 10 10.5C-13 P 1226

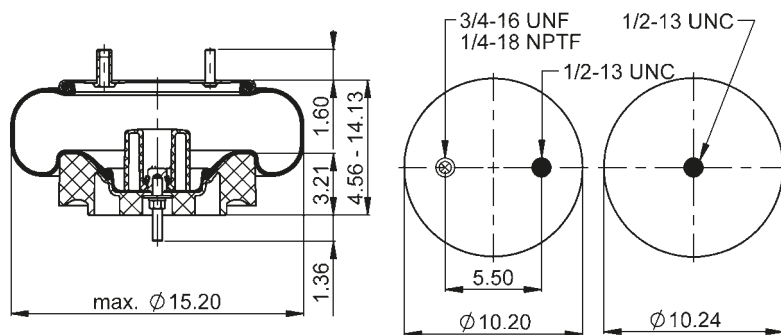

75741



**lb** 15.2 lb **No.** 9317517 10 10.5AV-12P513

**Cross-reference | Cruce de Referencia**  
Firestone W01-358-8617

- 1/4-18 NPTF: max. 22 lb-ft
- 1/2-13 UNC: max. 35 lb-ft
- 3/4-16 UNF: max. 50 lb-ft



### 10 10.5-15 P 460

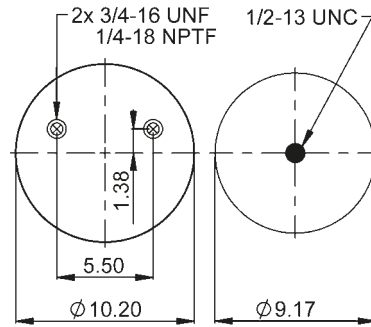
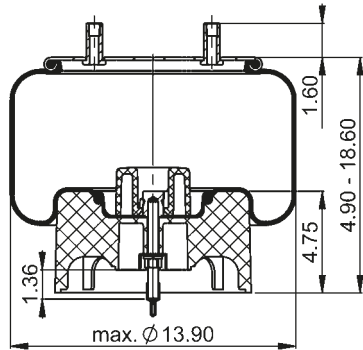

64645



**lb** 13.2 lb **No.** 9310704

**Cross-reference | Cruce de Referencia**  
 Firestone W01-358-8709  
 Goodyear 1R13-159

**Manufacturer | Fabricante**  
 Hendrickson S-20900  
 S-21800  
 Navistar/Fleetrite 1R13-249

1/4-18 NPTF: max. 22 lb-ft  
 1/2-13 UNC: max. 35 lb-ft  
 3/4-16 UNF: max. 50 lb-ft

### 10 10.5-15 P 1036

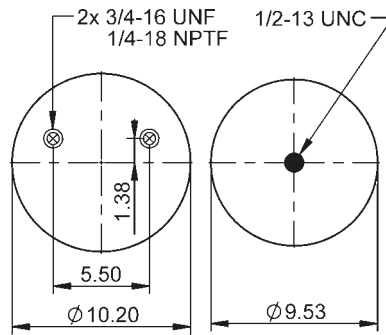
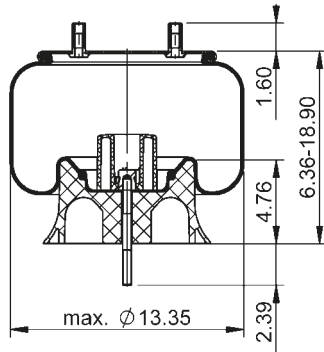

78139



**lb** 12.4 lb **No.** 9308128

**Manufacturer | Fabricante**  
 SAF Holland 90557414

1/4-18 NPTF: max. 22 lb-ft  
 1/2-13 UNC: max. 25 lb-ft  
 3/4-16 UNF: max. 35 lb-ft

### 10 10.5AV-16 P 1219

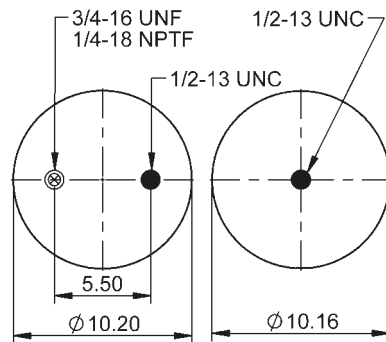
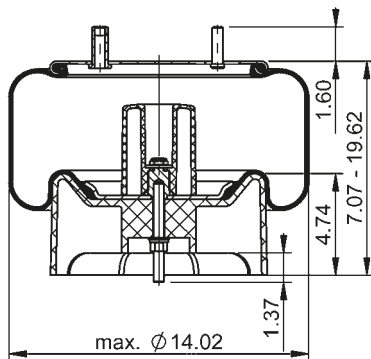

78239



**lb** 14.6 lb **No.** 9310179 70111

**Cross-reference | Cruce de Referencia**  
 Firestone W01-358-8539  
 Goodyear 1R13-188

**Manufacturer | Fabricante**  
 DANA/SPICER SR1JA100  
 SR1VA101-1  
 SR1VA105  
 Dayton 352-9082  
 Hendrickson S-29892

1/4-18 NPTF: max. 22 lb-ft  
 1/2-13 UNC: max. 35 lb-ft  
 3/4-16 UNF: max. 50 lb-ft

### 10 10.5AV-16 P 1222

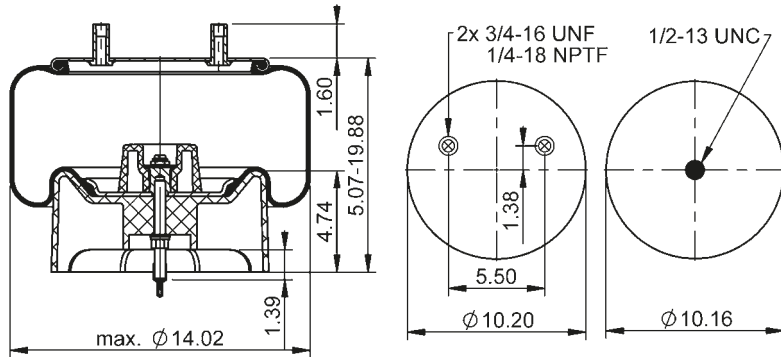

78238



**lb** 14.3 lb **No.** 9310179

**Cross-reference | Cruce de Referencia**

Goodyear 1R13-189

**Manufacturer | Fabricante**

Hendrickson SR1VA104

- 1/4-18 NPTF: max. 22 lbft
- 1/2-13 UNC: max. 35 lbft
- 3/4-16 UNF: max. 50 lbft

### 10 10.5V-22 S 1179

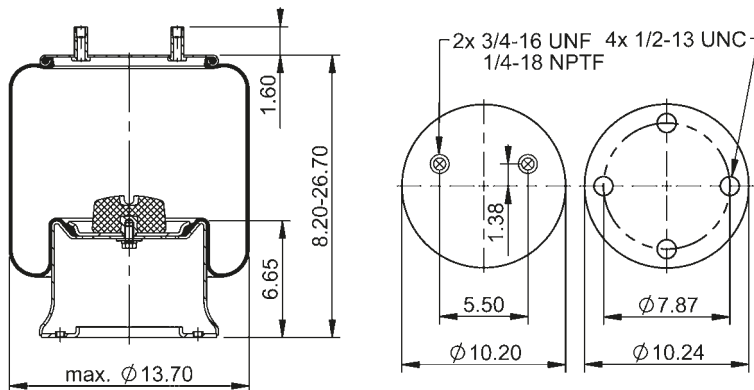

75268



**lb** 27.8 lb **No.** 9317652

**Cross-reference | Cruce de Referencia**

Goodyear 1R13-171  
1R13-237

**Manufacturer | Fabricante**

Hendrickson C-25871

- 1/4-18 NPTF: max. 22 lbft
- 1/2-13 UNC: max. 35 lbft
- 3/4-16 UNF: max. 50 lbft

### 10 10.5V-24 S 1060

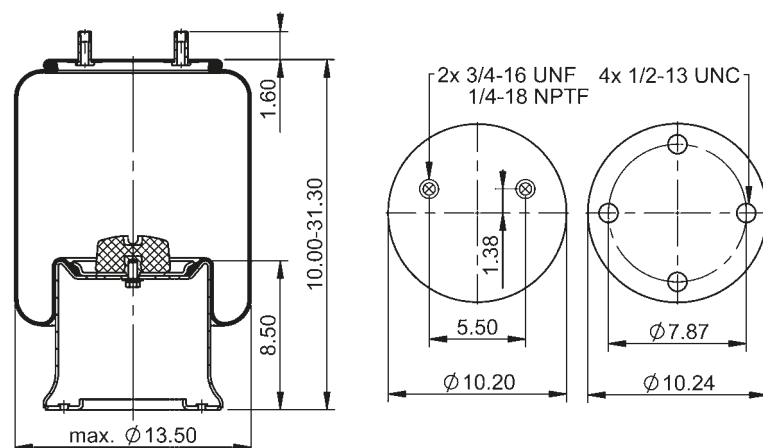

73913



**lb** 30.6 lb **No.** 9310291

**Cross-reference | Cruce de Referencia**

Goodyear 1R13-172  
1R13-235

**Manufacturer | Fabricante**

Hendrickson C-25872

- 1/4-18 NPTF: max. 22 lbft
- 1/2-13 UNC: max. 35 lbft
- 3/4-16 UNF: max. 50 lbft

### 11 10.5-13 A 168

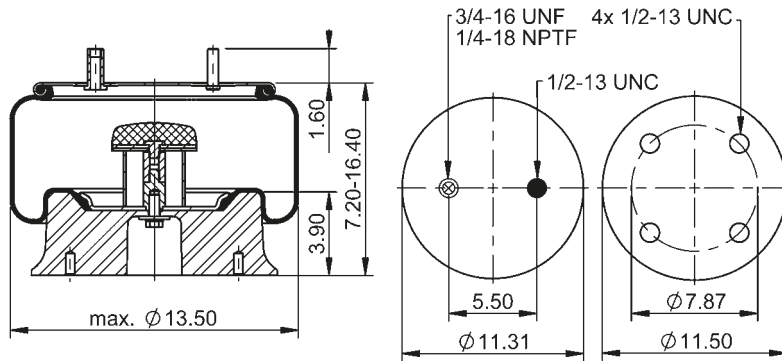

72932



**lb** 20.2 lb **No.** 9314352

**Manufacturer | Fabricante**  
Raydan 211-00-050  
211-00-250

1/4-18 NPTF: max. 22 lb-ft  
1/2-13 UNC: max. 35 lb-ft  
3/4-16 UNF: max. 50 lb-ft

### 11 10.5-13 A 761

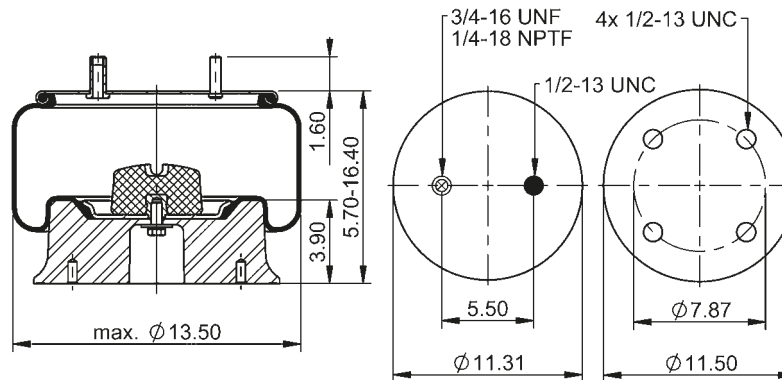

64707



**lb** 18.3 lb **No.** 9313481

**Manufacturer | Fabricante**  
Raydan 211-00-026

1/4-18 NPTF: max. 22 lb-ft  
1/2-13 UNC: max. 35 lb-ft  
3/4-16 UNF: max. 50 lb-ft

### 11 10.5-13 A 1132

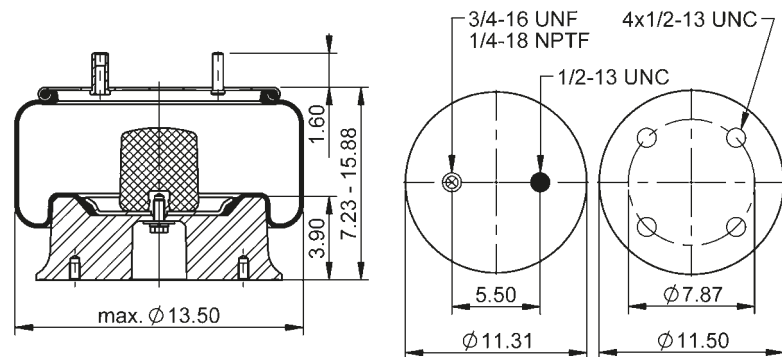

74618



**lb** 17.4 lb **No.** 9320165

**Cross-reference | Cruce de Referencia**  
Firestone W01-358-8760  
Goodyear 1R13-139

**Manufacturer | Fabricante**  
Granning 7593

1/4-18 NPTF: max. 22 lb-ft  
1/2-13 UNC: max. 35 lb-ft  
3/4-16 UNF: max. 50 lb-ft

### 11 10.5-15 A 414

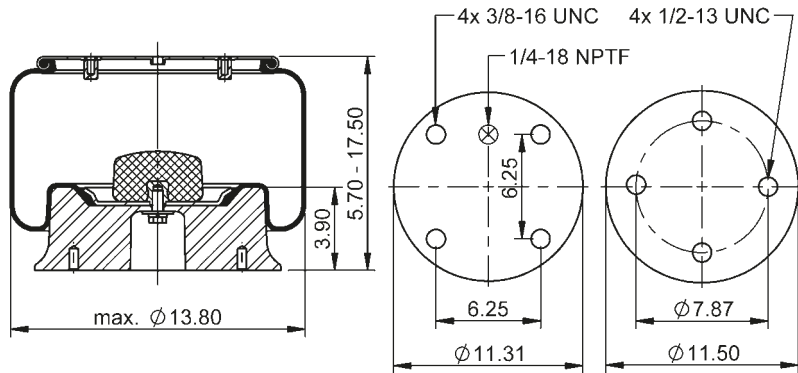

64424



**lb** 22.0 lb **No.** 9320165

**Cross-reference | Cruce de Referencia**

Firestone	W01-358-9215
Goodyear	1R14-037

**Manufacturer | Fabricante**

Dayton	352-9215
Hendrickson	S-3648
Loadguard	SC2047
Navistar/Fleetrite	554781C1
SAF Holland	57009215

1/4-18 NPTF: max. 22 lb-ft  
 3/8-16 UNC: max. 20 lb-ft  
 1/2-13 UNC: max. 35 lb-ft

### 11 10.5-15 A 415

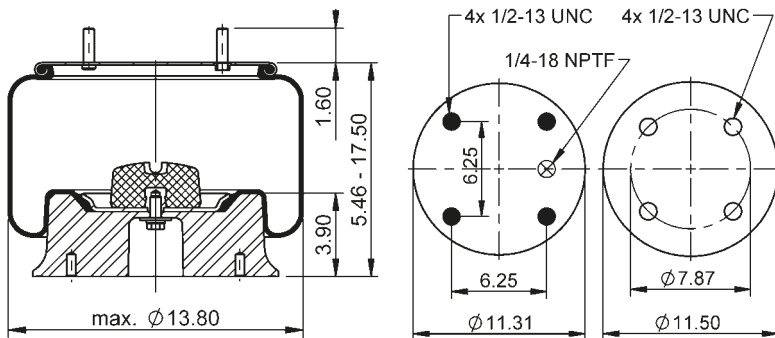

64253



**lb** 21.4 lb **No.** 9320165

**Cross-reference | Cruce de Referencia**

Firestone	W01-358-9200
Goodyear	1R14-038
	1R14-068

**Manufacturer | Fabricante**

Meritor	200458
Hendrickson	S-3839
SAF Holland	57009200
Watson & Chalin	AS-0082
Navistar/Fleetrite	1681746C1
Ridewell	1003589200C
Loadguard	SC2116
Suspensions, Inc.	200458
and more	

1/4-18 NPTF: max. 22 lb-ft  
 1/2-13 UNC: max. 35 lb-ft

### 11 10.5-15 A 419

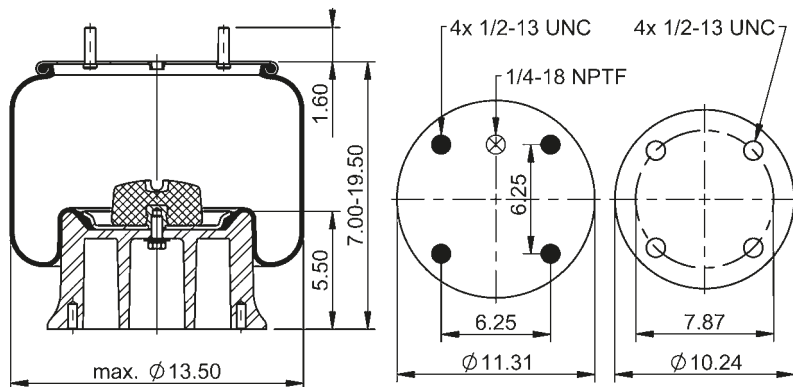

64425



**lb** 21.2 lb **No.** 9305216

**Cross-reference | Cruce de Referencia**

Firestone	W01-358-8088
-----------	--------------

**Manufacturer | Fabricante**

Ridewell	1003588088C
----------	-------------

1/4-18 NPTF: max. 22 lb-ft  
 1/2-13 UNC: max. 35 lb-ft

### 11 10.5-15 A 420

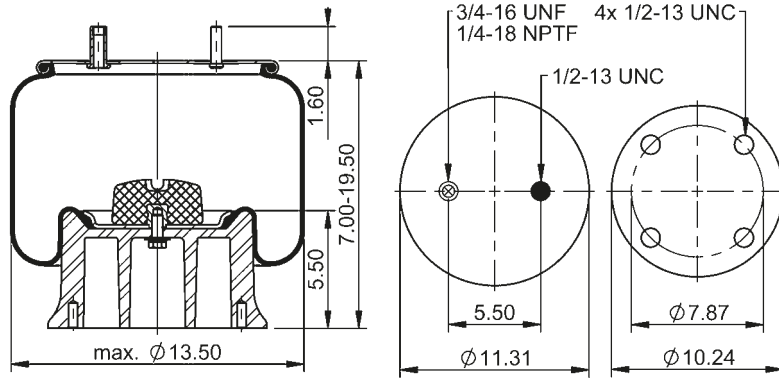

64426



**lb** 21.1 lb **No.** 9305216

**Cross-reference | Cruce de Referencia**  
 Firestone W01-358-9277

**Manufacturer | Fabricante**  
 Meritor 201531  
 Reyco 24556-01  
 Ridewell 1003589277C

1/4-18 NPTF: max. 22 lb-ft  
 1/2-13 UNC: max. 35 lb-ft

### 11 10.5-15 A 421

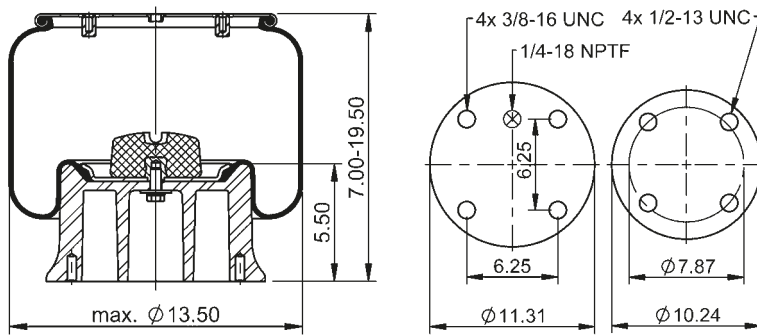

64427



**lb** 21.1 lb **No.** 9305216

**Cross-reference | Cruce de Referencia**  
 Firestone W01-358-9216

1/4-18 NPTF: max. 22 lb-ft  
 3/8-16 UNC: max. 20 lb-ft  
 1/2-13 UNC: max. 35 lb-ft

### 11 10.5-15 A 422

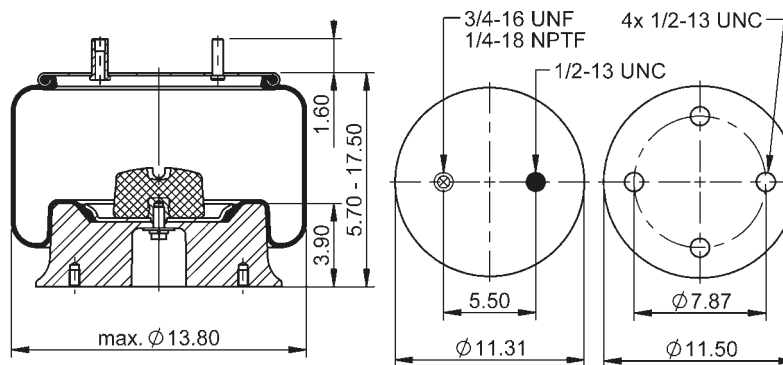

64428



**lb** 21.2 lb **No.** 9320165

**Cross-reference | Cruce de Referencia**  
 Firestone W01-358-9218  
 Goodyear 1R13-120

**Manufacturer | Fabricante**  
 Meritor 201222  
 Loadguard SC2782  
 Ridewell 1003589218C  
 SAF Holland 90557209  
 Suspensions, Inc. 201222  
 Watson & Chalin AS-0073

1/4-18 NPTF: max. 22 lb-ft  
 1/2-13 UNC: max. 35 lb-ft  
 3/4-16 UNF: max. 50 lb-ft

### 11 10.5-15 A 506

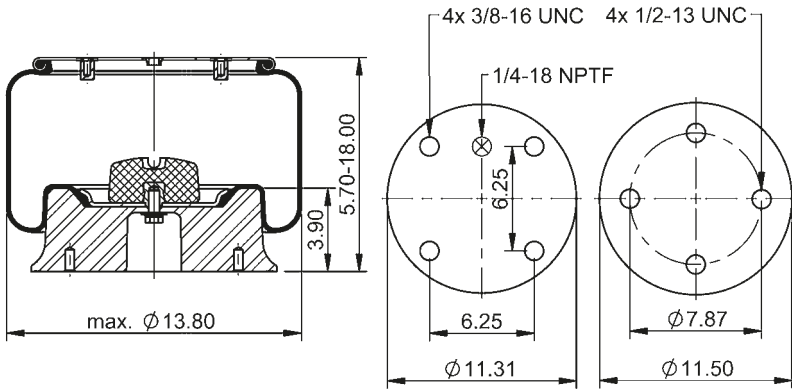

64429



**lb** 21.2 lb **No.** 9320165

**Cross-reference | Cruce de Referencia**  
Firestone W01-358-9204

- 1/4-18 NPTF: max. 22 lb-ft
- 3/8-16 UNC: max. 20 lb-ft
- 1/2-13 UNC: max. 35 lb-ft

### 11 10.5-15 A 1141

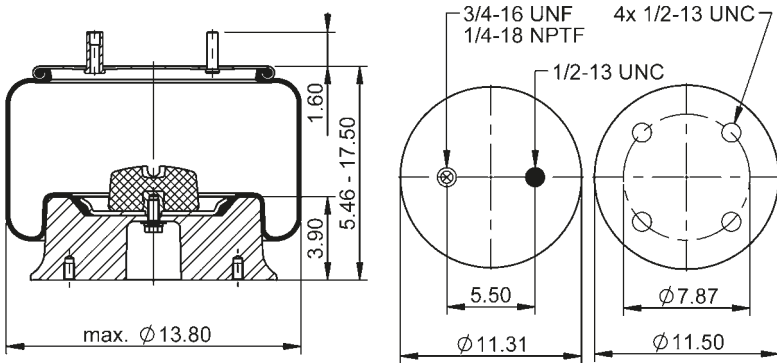

74766



**lb** 20.0 lb **No.** 9320165

**Cross-reference | Cruce de Referencia**  
Firestone W01-W35-9236

- Manufacturer | Fabricante**  
New Flyer 15201
- 1/4-18 NPTF: max. 22 lb-ft
  - 1/2-13 UNC: max. 35 lb-ft
  - 3/4-16 UNF: max. 50 lb-ft

### 11 10.5A-16 P 523

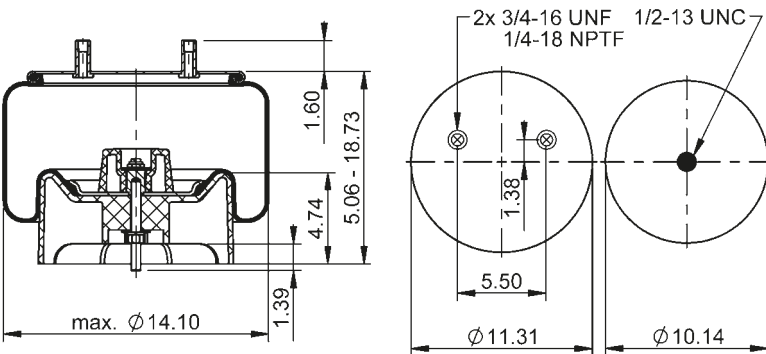

64421



**lb** 16.8 lb **No.** 9310179

**Cross-reference | Cruce de Referencia**  
Firestone W01-358-8091  
Goodyear 1R14-171

- Manufacturer | Fabricante**  
Meritor A2258P1576  
Hendrickson C-20901  
Navistar/Fleetrite 1R14-242
- 1/4-18 NPTF: max. 22 lb-ft
  - 1/2-13 UNC: max. 35 lb-ft
  - 3/4-16 UNF: max. 50 lb-ft

### 11 10.5A-16 P 934

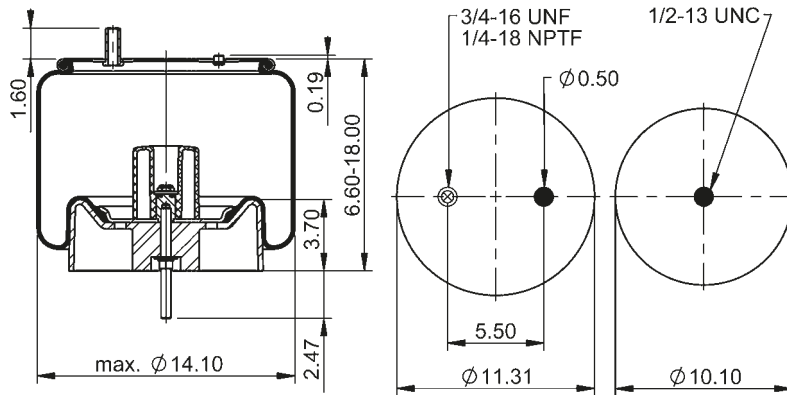

67447



**lb** 16.7 lb **No.** 9312908

**Manufacturer | Fabricante**  
ZF 50173-6800

**1/4-18 NPTF:** max. 22 lb-ft  
**1/2-13 UNC:** max. 35 lb-ft  
**3/4-16 UNF:** max. 50 lb-ft

### 11 10.5C-16 A 320

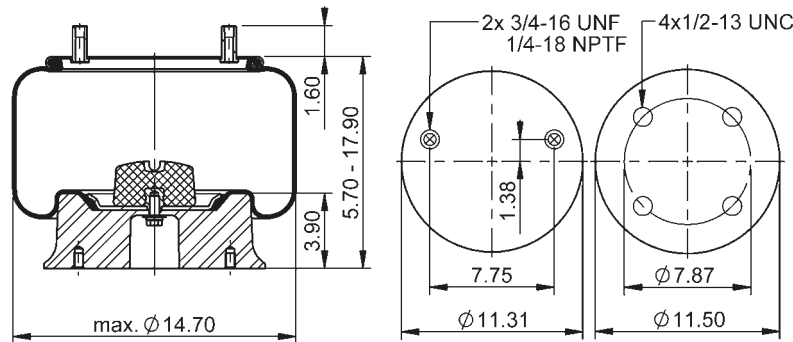

64254



**lb** 21.4 lb **No.** 9320165 **←** 11 10.5C-16 A 782

**Cross-reference | Cruce de Referencia**

Firestone W01-358-8050  
Goodyear 1R14-039

**Manufacturer | Fabricante**

Meritor 201680  
Hendrickson B-4771  
B-12514-013  
Navistar/Fleetrite 1685174C1  
Reyco 23631-01  
SAF Holland 57008050  
Watson & Chalin AS-0039  
Volvo 3130498  
and more

**1/4-18 NPTF:** max. 22 lb-ft  
**1/2-13 UNC:** max. 35 lb-ft  
**3/4-16 UNF:** max. 50 lb-ft

### 11 10.5C-16 A 378

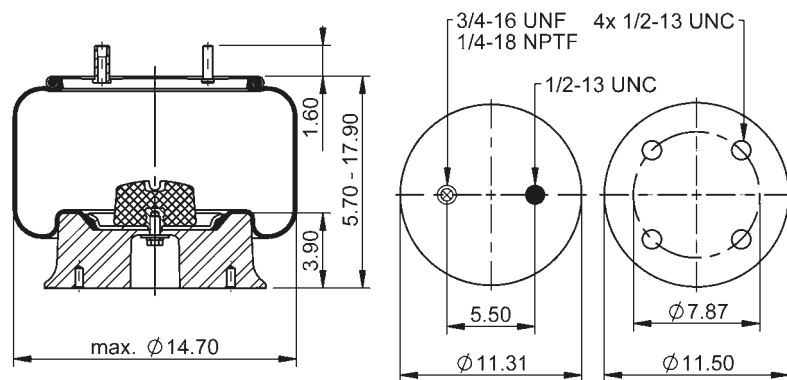

64357



**lb** 21.0 lb **No.** 9320165

**Cross-reference | Cruce de Referencia**

Firestone W01-358-8052  
Goodyear 1R14-042

**Manufacturer | Fabricante**

Hendrickson 36514-12  
B-12514-012  
Loadguard SC2121  
MCI 2992101C1  
Navistar/Fleetrite 1681747C1  
SAF Holland 57008052  
90557293  
Watson & Chalin AS-0078  
and more

**1/4-18 NPTF:** max. 22 lb-ft  
**1/2-13 UNC:** max. 35 lb-ft  
**3/4-16 UNF:** max. 50 lb-ft

### 11 10.5C-16 A 380

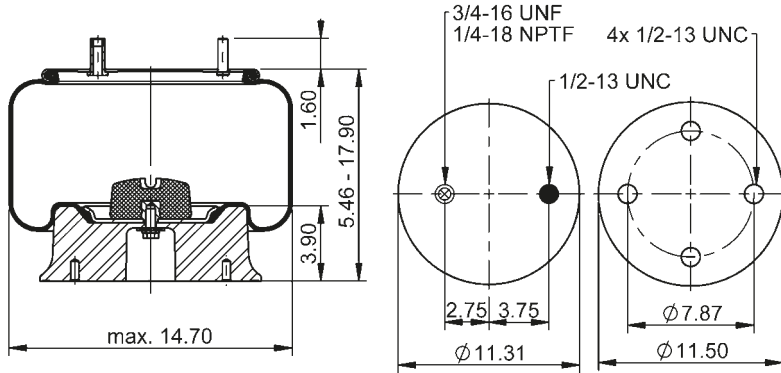

64358



**lb** 21.8 lb **No.** 9320165

**Cross-reference | Cruce de Referencia**

Firestone W01-358-8053  
Goodyear 1R14-094

**Manufacturer | Fabricante**

Gillig 5320415-0001  
MCI 2992101C1  
SAF Holland 90557098

1/4-18 NPTF: max. 22 lb-ft  
1/2-13 UNC: max. 35 lb-ft  
3/4-16 UNF: max. 50 lb-ft

### 11 10.5C-16 A 385

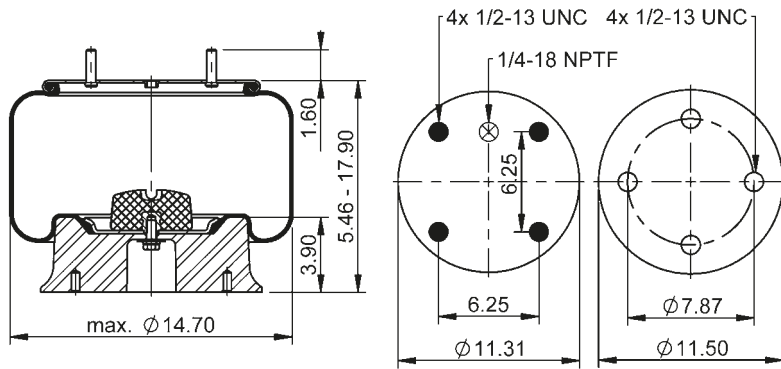

64359



**lb** 21.2 lb **No.** 9320165

**Cross-reference | Cruce de Referencia**

Firestone W01-358-8051

**Manufacturer | Fabricante**

Ridewell 1003588051C

1/4-18 NPTF: max. 22 lb-ft  
1/2-13 UNC: max. 35 lb-ft

### 11 10.5C-16 A 706

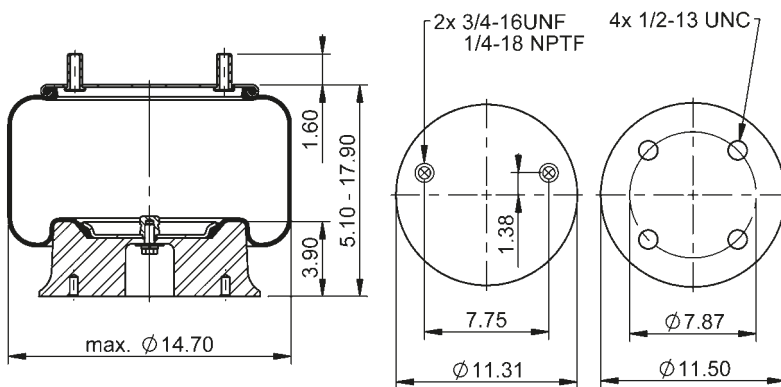

64628



**lb** 20.5 lb **No.** 9320165

**Cross-reference | Cruce de Referencia**

Goodyear 1R14-198

**Manufacturer | Fabricante**

Watson & Chalin AS-0180

1/4-18 NPTF: max. 22 lb-ft  
1/2-13 UNC: max. 35 lb-ft  
3/4-16 UNF: max. 50 lb-ft



### 11 10.5C-16 A 729

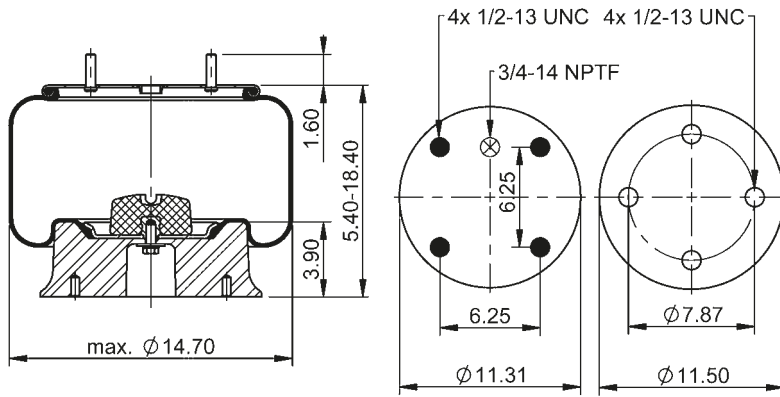

64660



**lb** 21.2 lb **No.** 9314352

**Cross-reference | Cruce de Referencia**  
 Firestone W01-358-8056  
 Goodyear 1R14-155

**Manufacturer | Fabricante**  
 Watson & Chalin AS-0186

1/2-13 UNC: max. 35 lb-ft  
 3/4-14 NPTF: max. 22 lb-ft

### 11 10.5C-16 A 834

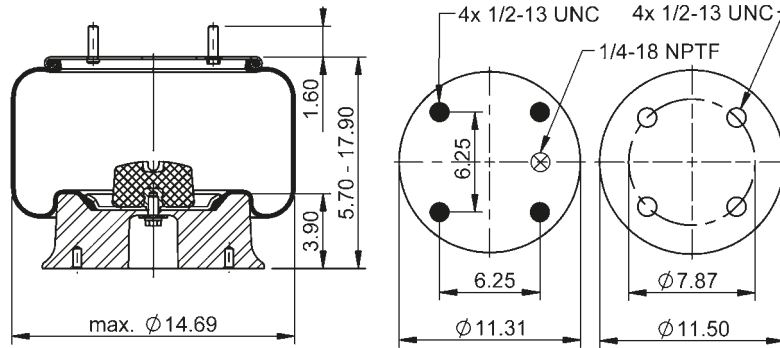

65906



**lb** 21.5 lb **No.** 9320165

**Manufacturer | Fabricante**  
 Silent Drive AS-65906

1/4-18 NPTF: max. 22 lb-ft  
 1/2-13 UNC: max. 35 lb-ft

### 11 10.5CT-16 A 943

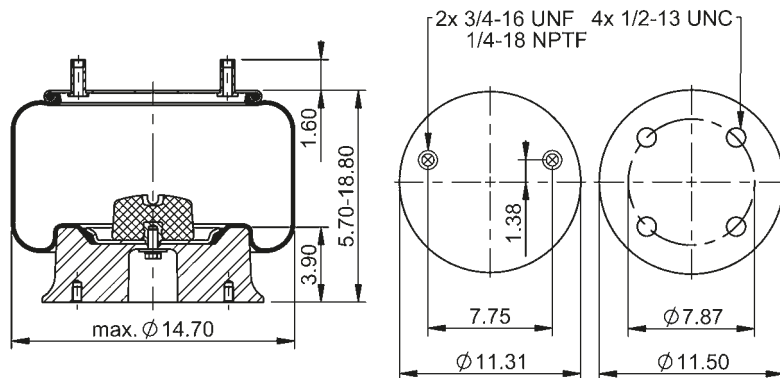

67442



**lb** 21.5 lb **No.** 9314352

**Manufacturer | Fabricante**  
 Watson & Chalin AS-0039

1/4-18 NPTF: max. 22 lb-ft  
 1/2-13 UNC: max. 35 lb-ft  
 3/4-16 UNF: max. 50 lb-ft

### 11 10.5E-16 A 214

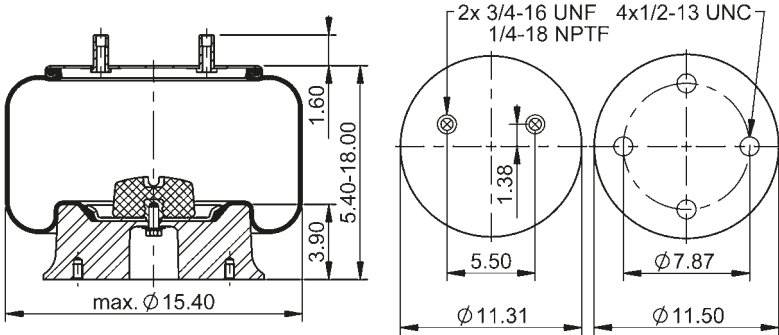

69701



**lb** 21.0 lb **No.** 9314352

**Manufacturer | Fabricante**  
SAF Holland 90557410

- 1/4-18 NPTF: max. 22 lb-ft
- 1/2-13 UNC: max. 35 lb-ft
- 3/4-16 UNF: max. 50 lb-ft

### 11 10.5-16.5 A 129

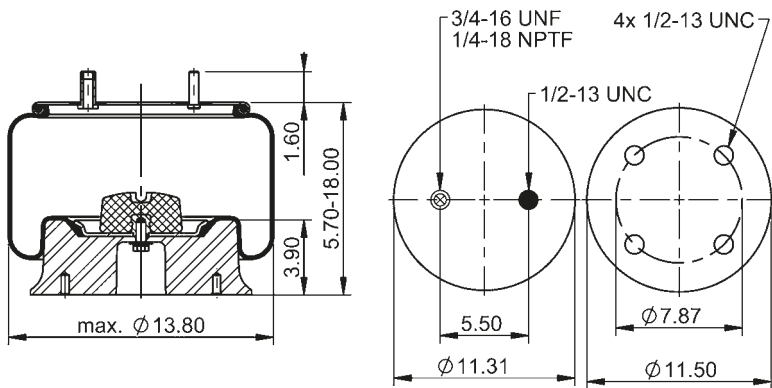

68792



**lb** 21.2 lb **No.** 9313481

**Manufacturer | Fabricante**  
Raydan 211-00-025

- 1/4-18 NPTF: max. 22 lb-ft
- 1/2-13 UNC: max. 35 lb-ft
- 3/4-16 UNF: max. 50 lb-ft

### 11 10.5-16.5 A 751

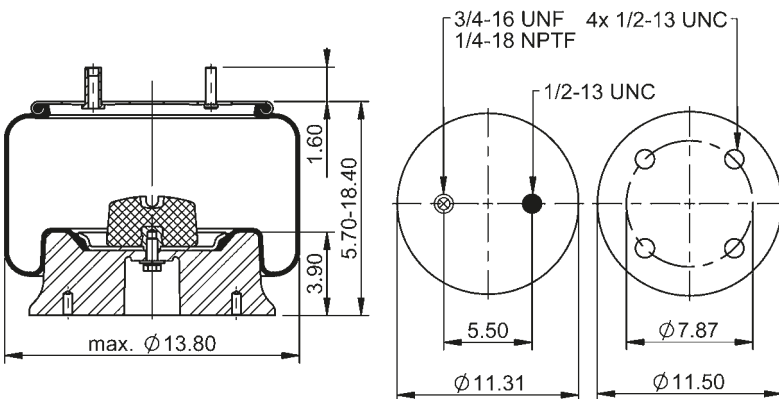

64689



**lb** 21.2 lb **No.** 9314352

**Manufacturer | Fabricante**  
Raydan 211-00-027

- 1/4-18 NPTF: max. 22 lb-ft
- 1/2-13 UNC: max. 35 lb-ft
- 3/4-16 UNF: max. 50 lb-ft

### 11 10.5-16.5 A 976

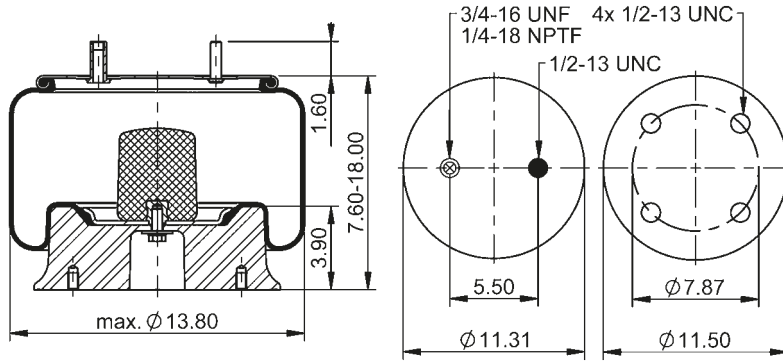

68534



**lb** 20.5 lb **No.** 9314352

**Manufacturer | Fabricante**  
Raydan 211-00-047

**1/4-18 NPTF:** max. 22 lb-ft  
**1/2-13 UNC:** max. 35 lb-ft  
**3/4-16 UNF:** max. 50 lb-ft

### 11 10.5B-16.5 P 279

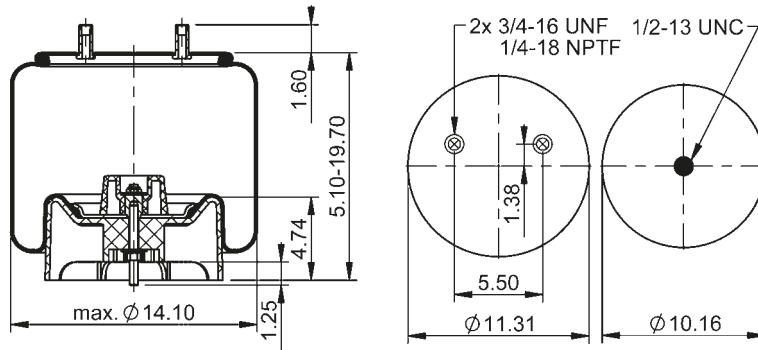

79093



**lb** 16.6 lb **No.** 9310179

**Manufacturer | Fabricante**  
Meritor A2258D1668

**1/4-18 NPTF:** max. 22 lb-ft  
**1/2-13 UNC:** max. 35 lb-ft  
**3/4-16 UNF:** max. 50 lb-ft

### 11 10.5-17 A 133

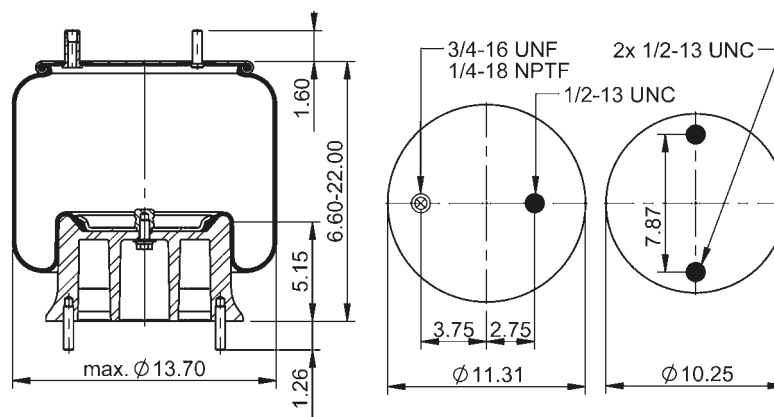

77754



**lb** 20.1 lb **No.** 9305216

**Manufacturer | Fabricante**  
SAF Holland 90557392

**1/4-18 NPTF:** max. 22 lb-ft  
**1/2-13 UNC:** max. 35 lb-ft  
**3/4-16 UNF:** max. 50 lb-ft

### 11 10.5-17 A 170

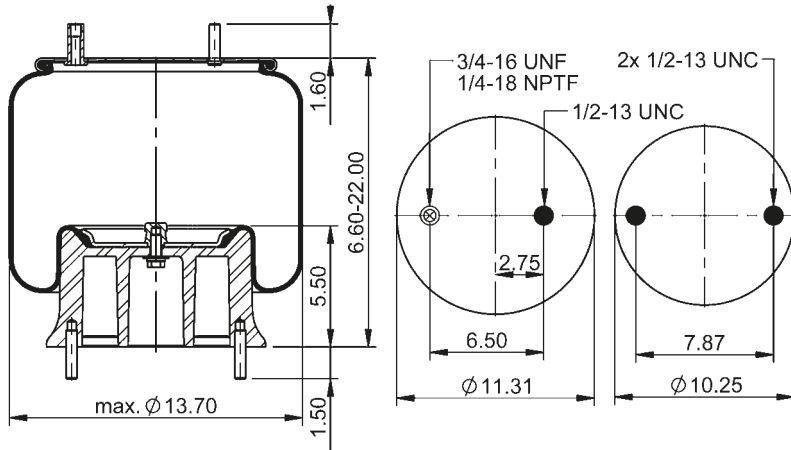

78165



**lb** 20.1 lb **No.** 9305216

**Manufacturer | Fabricante**  
SAF Holland 90557394

**1/4-18 NPTF:** max. 22 lb-ft  
**1/2-13 UNC:** max. 35 lb-ft  
**3/4-16 UNF:** max. 50 lb-ft

### 11 10.5-17 A 208

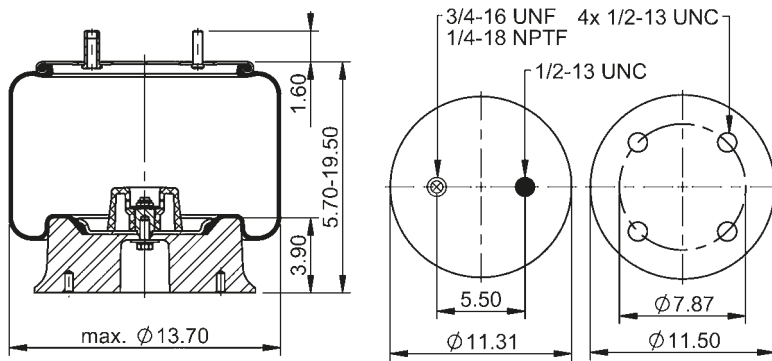

69629



**lb** 20.9 lb **No.** 9320165

**Cross-reference | Cruce de Referencia**  
Firestone W01-358-9811

**Manufacturer | Fabricante**  
Rowe Truck 0266ASC1600HL

**1/4-18 NPTF:** max. 22 lb-ft  
**1/2-13 UNC:** max. 35 lb-ft  
**3/4-16 UNF:** max. 50 lb-ft

### 11 10.5-17 A 316

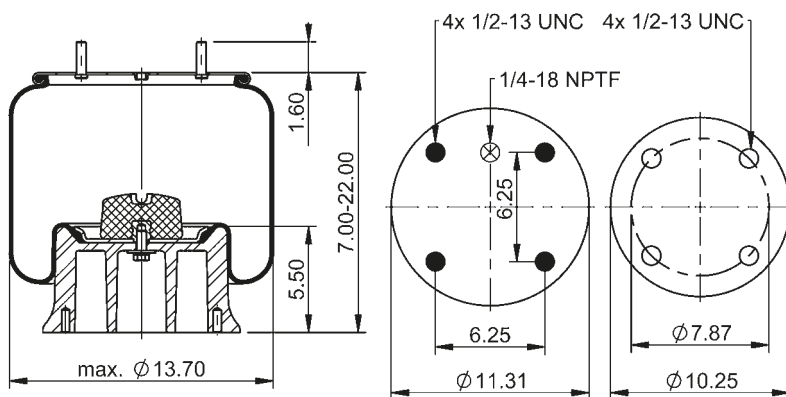

64342



**lb** 21.2 lb **No.** 9305216 **←** 11 10.5-17 A 366

**Cross-reference | Cruce de Referencia**

Firestone W01-358-9177  
W01-358-9179  
Goodyear 1R14-028

**Manufacturer | Fabricante**  
Granning 6426  
Hendrickson S-2065  
Loadguard SC2046  
Navistar/Fleetrite 554779C1  
Ridewell 1003589177C  
SAF Holland 90557003  
Volvo 3130494  
Watson & Chalin AS-0010  
and more

**1/4-18 NPTF:** max. 22 lb-ft  
**1/2-13 UNC:** max. 35 lb-ft

### 11 10.5-17 A 317

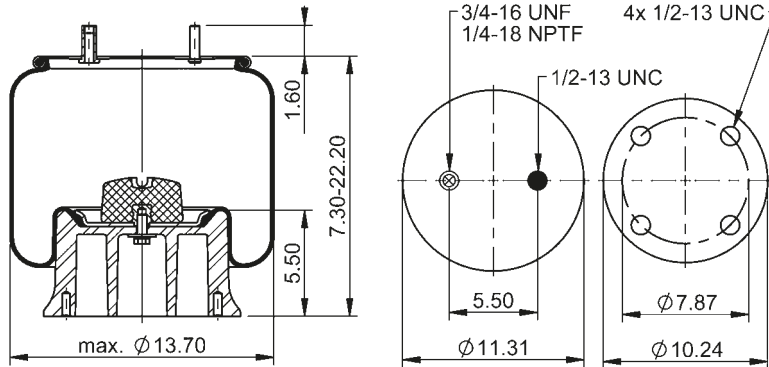

64272



**lb** 21.2 lb **No.** 9305216

**Cross-reference | Cruce de Referencia**  
 Firestone W01-358-9121

**Manufacturer | Fabricante**  
 Hendrickson S-13160  
 SAF Holland 90557019  
 90557052  
 90557078  
 90557083  
 90557110  
 Volvo 85101159  
 Watson & Chalin AS-0013  
 and more

1/4-18 NPTF: max. 22 lb-ft  
 1/2-13 UNC: max. 35 lb-ft  
 3/4-16 UNF: max. 50 lb-ft

### 11 10.5-17 A 364

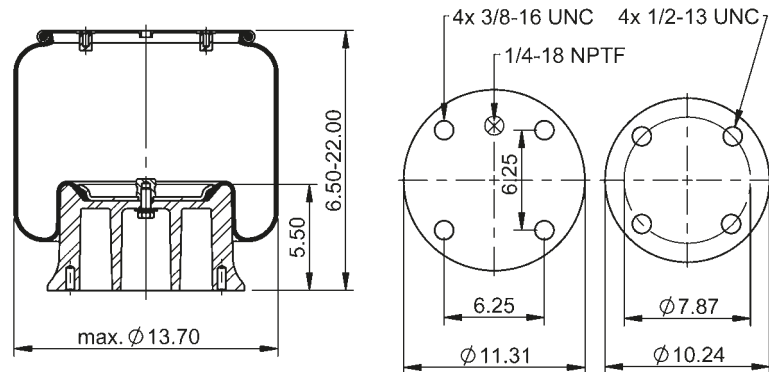

64343



**lb** 19.8 lb **No.** 9305216

**Cross-reference | Cruce de Referencia**  
 Firestone W01-358-9148  
 Goodyear 1R14-026

**Manufacturer | Fabricante**  
 Dayton 352-9148  
 Hendrickson S-13053  
 Loadguard SC2113  
 SC2042  
 Navistar/Fletrite 554778C1  
 1681743C1  
 Peerless 0550-00070  
 Taurus AS621-9148

1/4-18 NPTF: max. 22 lb-ft  
 3/8-16 UNC: max. 20 lb-ft  
 1/2-13 UNC: max. 35 lb-ft

### 11 10.5-17 A 365

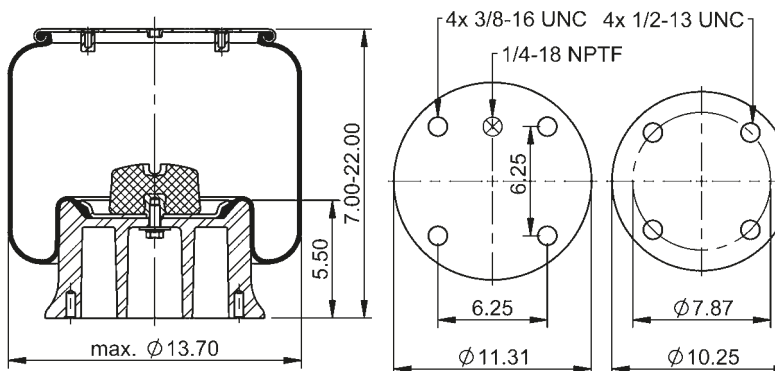

64344



**lb** 20.1 lb **No.** 9305216

**Cross-reference | Cruce de Referencia**  
 Firestone W01-358-9149  
 Goodyear 1R14-018

**Manufacturer | Fabricante**  
 Hendrickson S-13045  
 Loadguard SC2112  
 SC2043  
 Navistar/Fletrite 1681741C1  
 554776C1  
 Peerless 0550-00010  
 Ridewell 1003589149C  
 SAF Holland 57009149  
 and more

1/4-18 NPTF: max. 22 lb-ft  
 3/8-16 UNC: max. 20 lb-ft  
 1/2-13 UNC: max. 35 lb-ft

### 11 10.5-17 A 367

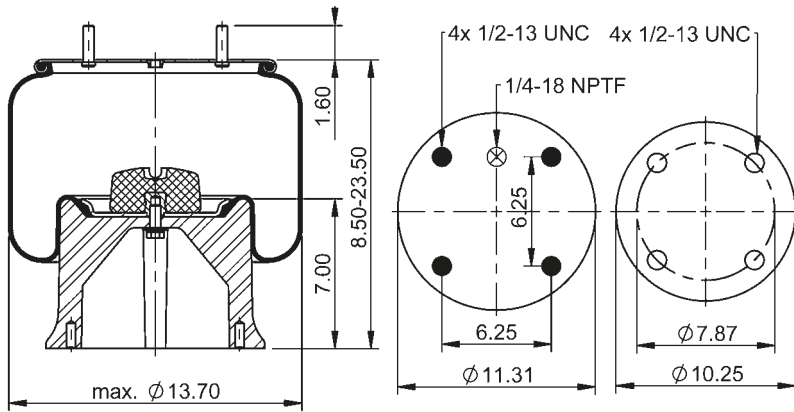

64346



**lb** 24.7 lb **No.** 9305215

**Cross-reference | Cruce de Referencia**

Firestone	W01-358-9961
Goodyear	1R14-115

**Manufacturer | Fabricante**

Loadguard	SC2778
Ridewell	1003589961C
Taurus	AS621-9961

1/4-18 NPTF: max. 22 lb-ft  
1/2-13 UNC: max. 35 lb-ft

### 11 10.5-17 A 368

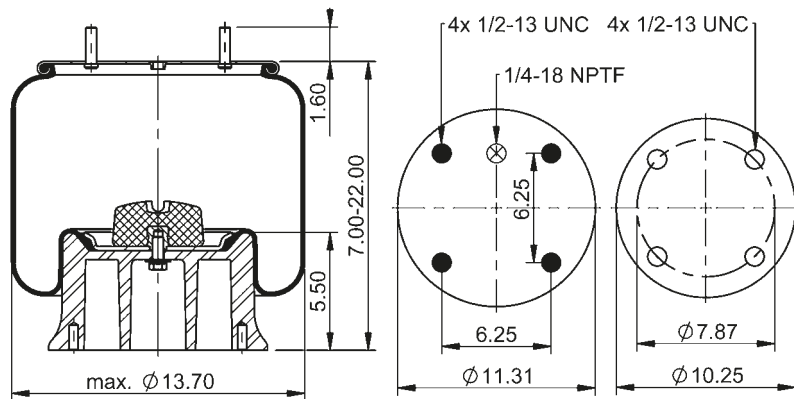

65358



**lb** 21.2 lb **No.** 9305216

**Cross-reference | Cruce de Referencia**

Firestone	W01-358-9135
-----------	--------------

**Manufacturer | Fabricante**

Dart	21-4048
Unit Rig	1016034

1/4-18 NPTF: max. 22 lb-ft  
1/2-13 UNC: max. 35 lb-ft

### 11 10.5-17 A 377

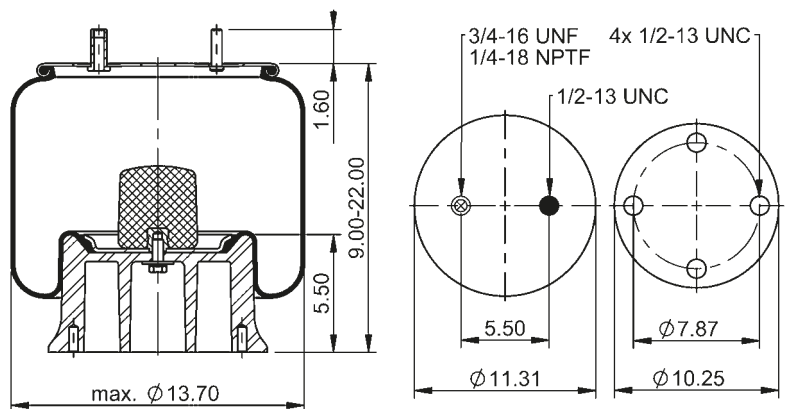

64347



**lb** 21.6 lb **No.** 9305216

**Cross-reference | Cruce de Referencia**

Firestone	W01-358-9144
Goodyear	1R13-047
	1R14-160

**Manufacturer | Fabricante**

SAF Holland	90557155
	90557323

1/4-18 NPTF: max. 22 lb-ft  
1/2-13 UNC: max. 35 lb-ft  
3/4-16 UNF: max. 50 lb-ft

### 11 10.5-17 A 388

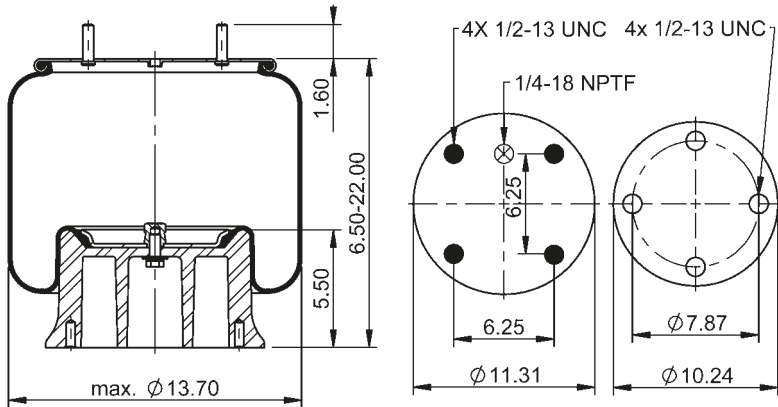

64348



**lb** 19.9 lb **No.** 9305216

**Cross-reference | Cruce de Referencia**  
Firestone W01-358-9221

**Manufacturer | Fabricante**  
Load Air P60-733  
Sauer

1/4-18 NPTF: max. 22 lb-ft  
1/2-13 UNC: max. 35 lb-ft

### 11 10.5-17 A 405

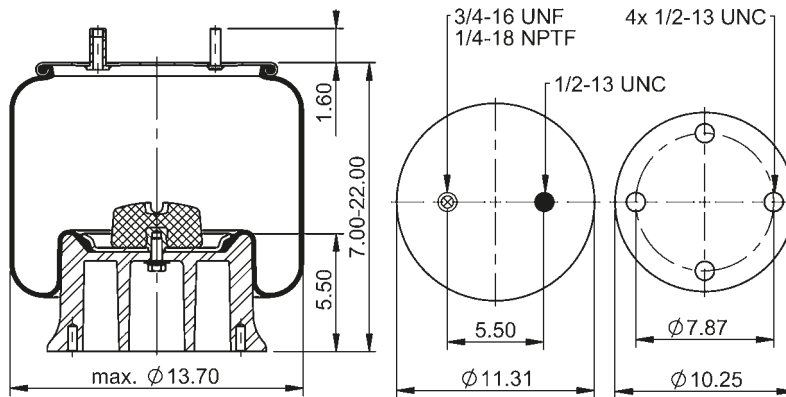

64349



**lb** 21.1 lb **No.** 9305216

**Cross-reference | Cruce de Referencia**  
Firestone W01-358-9164  
Goodyear 1R14-159

**Manufacturer | Fabricante**  
R&S Truck 1090326

1/4-18 NPTF: max. 22 lb-ft  
1/2-13 UNC: max. 35 lb-ft  
3/4-16 UNF: max. 50 lb-ft

### 11 10.5-17 A 507

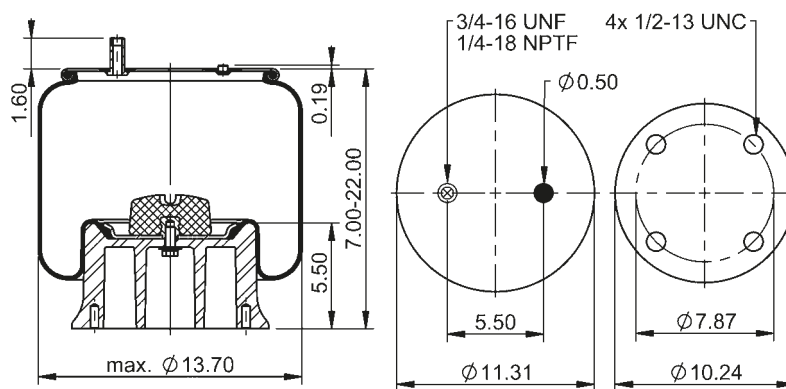

64350



**lb** 21.1 lb **No.** 9305216

**Cross-reference | Cruce de Referencia**  
Firestone W01-358-8778  
Goodyear 1R14-130

**Manufacturer | Fabricante**  
Ridewell 1003588778C  
SAF Holland 90557164

1/4-18 NPTF: max. 22 lb-ft  
1/2-13 UNC: max. 35 lb-ft  
3/4-16 UNF: max. 50 lb-ft

### 11 10.5-17 A 556

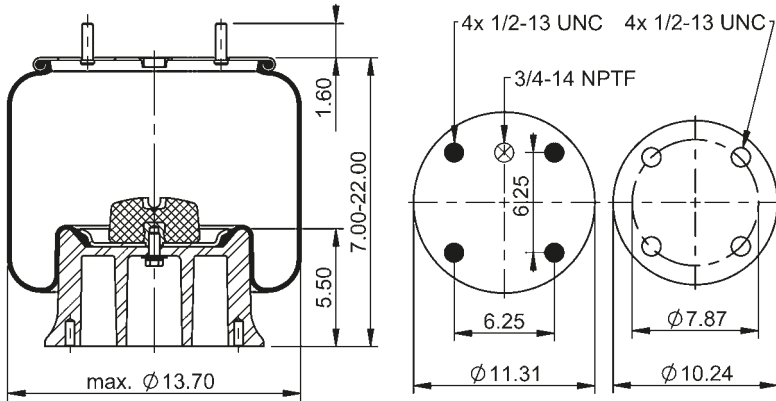

64351



**lb** 21.2 lb **No.** 9305216

**Cross-reference | Cruce de Referencia**  
 Firestone W01-358-9116

**1/2-13 UNC:** max. 35 lb-ft  
**3/4-14 NPTF:** max. 22 lb-ft

### 11 10.5F-17 P 745

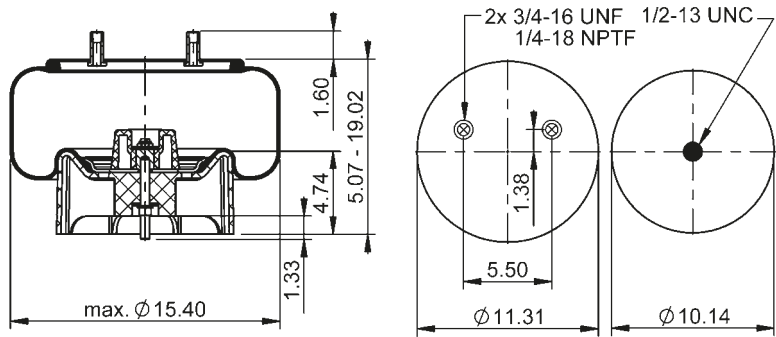

65593



**lb** 17.0 lb **No.** 9310179

**Cross-reference | Cruce de Referencia**  
 Firestone W01-358-8774  
 Goodyear 1R14-190  
 1R14-172

**Manufacturer | Fabricante**

Hendrickson C-25873  
 Watson & Chalin AS-0159  
 AS-0159-1G

**1/4-18 NPTF:** max. 22 lb-ft  
**1/2-13 UNC:** max. 35 lb-ft  
**3/4-16 UNF:** max. 50 lb-ft

### 11 10.5F-17.5 P 800

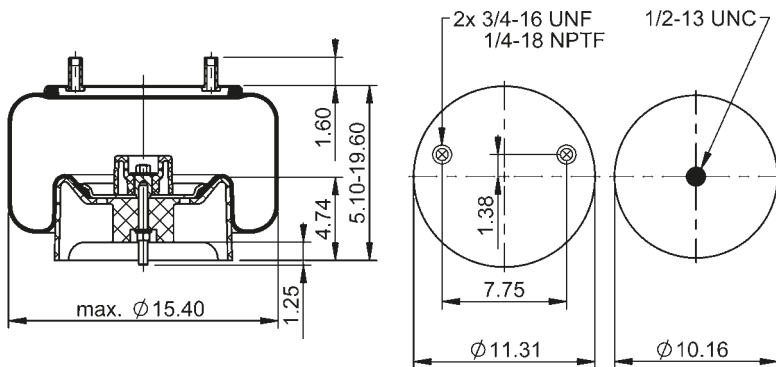

65218



**lb** 16.8 lb **No.** 9310179

**Manufacturer | Fabricante**

Watson & Chalin AS-0144

**1/4-18 NPTF:** max. 22 lb-ft  
**1/2-13 UNC:** max. 35 lb-ft  
**3/4-16 UNF:** max. 50 lb-ft



### 11 10.5F-17.5 P 829

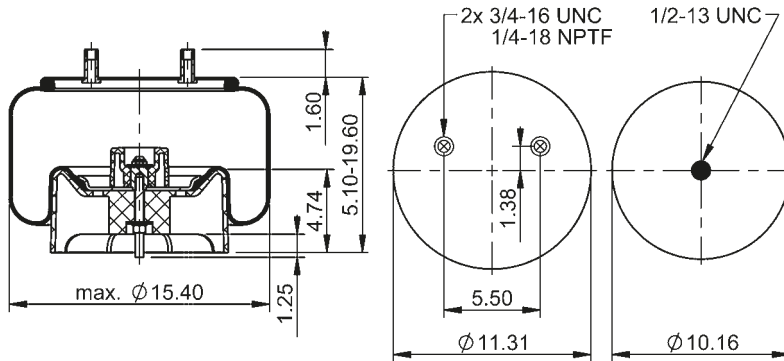

65796



**lb** 17.0 lb **No.** 9310179

**Manufacturer | Fabricante**  
Watson & Chalin AS-0159-1C

- 1/4-18 NPTF: max. 22 lb-ft
- 1/2-13 UNC: max. 35 lb-ft
- 3/4-16 UNF: max. 50 lb-ft

### 11 10.5B-18 P 743

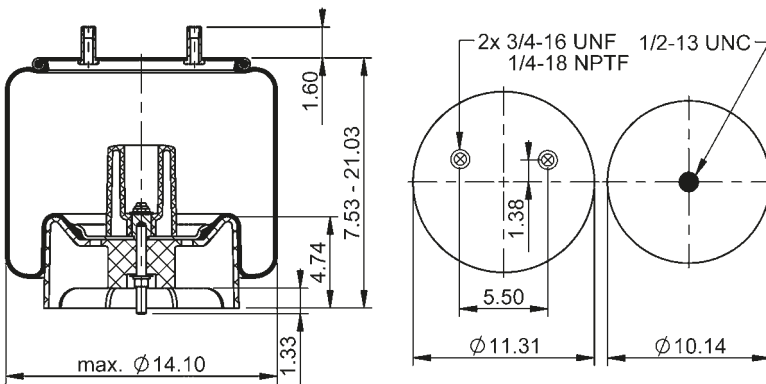

65368



**lb** 18.0 lb **No.** 9310179

**Cross-reference | Cruce de Referencia**  
Firestone W01-358-8093

**Manufacturer | Fabricante**  
Hendrickson C-23748

- 1/4-18 NPTF: max. 22 lb-ft
- 1/2-13 UNC: max. 35 lb-ft
- 3/4-16 UNF: max. 50 lb-ft

### 11 10.5E-18 A 213

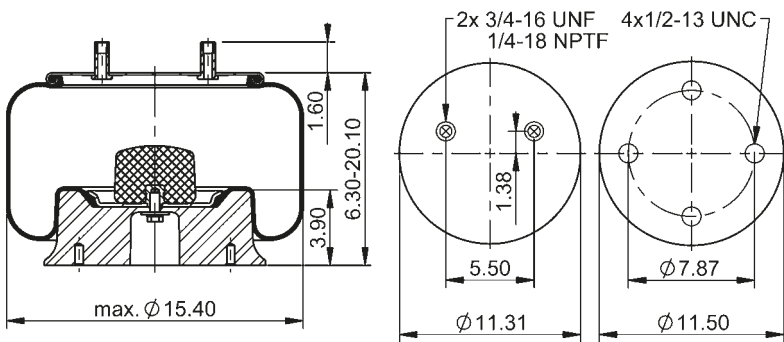

69690



**lb** 20.1 lb **No.** 9314352

**Manufacturer | Fabricante**  
SAF Holland 90557409

- 1/4-18 NPTF: max. 22 lb-ft
- 1/2-13 UNC: max. 35 lb-ft
- 3/4-16 UNF: max. 50 lb-ft

### 11 10.5-19 A 431

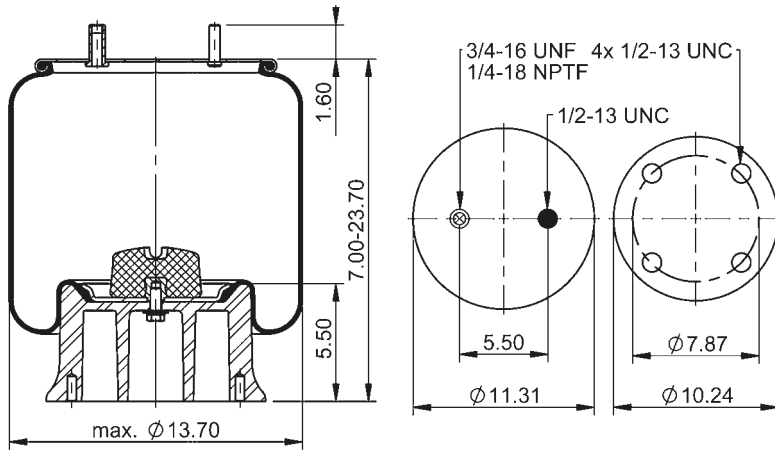

### 64391



**lb** 21.6 lb **No.** 9305216

#### Cross-reference | Cruce de Referencia

Firestone W01-358-9134  
Goodyear 1R14-137

#### Manufacturer | Fabricante

SAF Holland 90557125

- 1/4-18 NPTF: max. 22 lb-ft
- 1/2-13 UNC: max. 35 lb-ft
- 3/4-16 UNF: max. 50 lb-ft

### 11 10.5-19 A 432

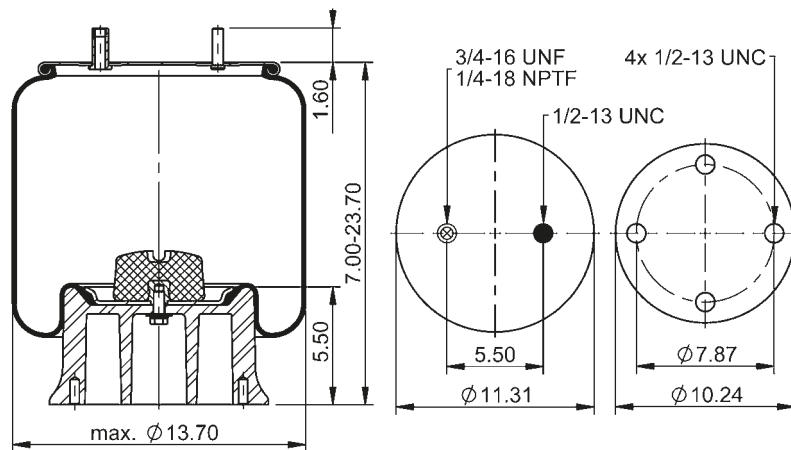

### 64392



**lb** 21.7 lb **No.** 9305216

#### Cross-reference | Cruce de Referencia

Firestone W01-358-9138

#### Manufacturer | Fabricante

SAF Holland 90557111

- 1/4-18 NPTF: max. 22 lb-ft
- 1/2-13 UNC: max. 35 lb-ft
- 3/4-16 UNF: max. 50 lb-ft

### 11 10.5-19 A 508

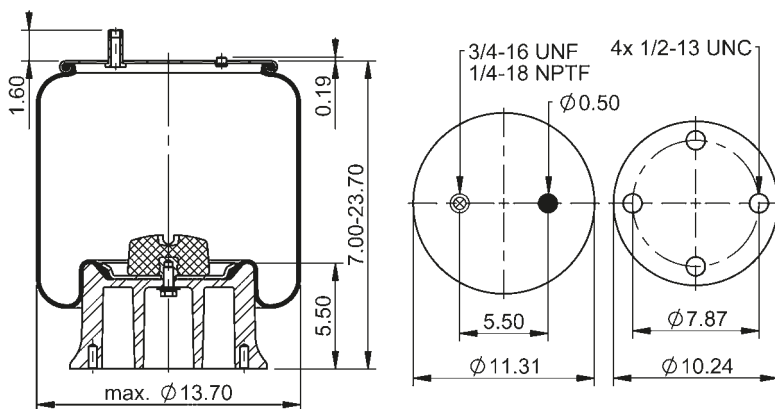

### 64393



**lb** 21.6 lb **No.** 9305216

#### Cross-reference | Cruce de Referencia

Firestone W01-358-8779

#### Manufacturer | Fabricante

SAF Holland 90557163

- 1/4-18 NPTF: max. 22 lb-ft
- 1/2-13 UNC: max. 35 lb-ft
- 3/4-16 UNF: max. 50 lb-ft

### 11 10.5-19 A 509

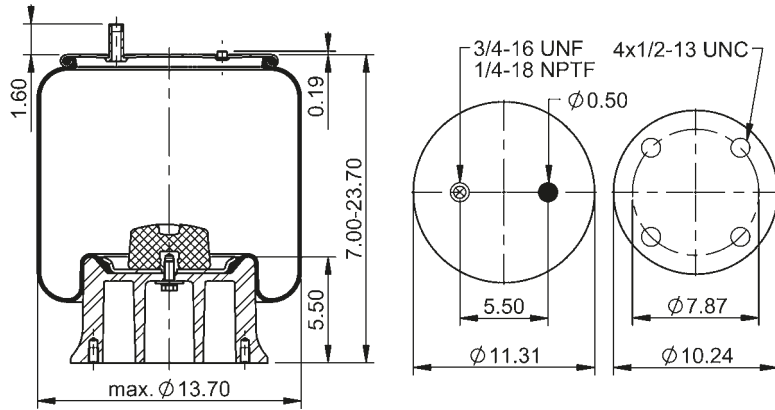

64289



**lb** 21.6 lb **No.** 9305216

**Cross-reference | Cruce de Referencia**  
Firestone W01-358-8780

**Manufacturer | Fabricante**  
SAF Holland 90557162

1/4-18 NPTF: max. 22 lb-ft  
1/2-13 UNC: max. 35 lb-ft  
3/4-16 UNF: max. 50 lb-ft

### 11 10.5-19 A 557

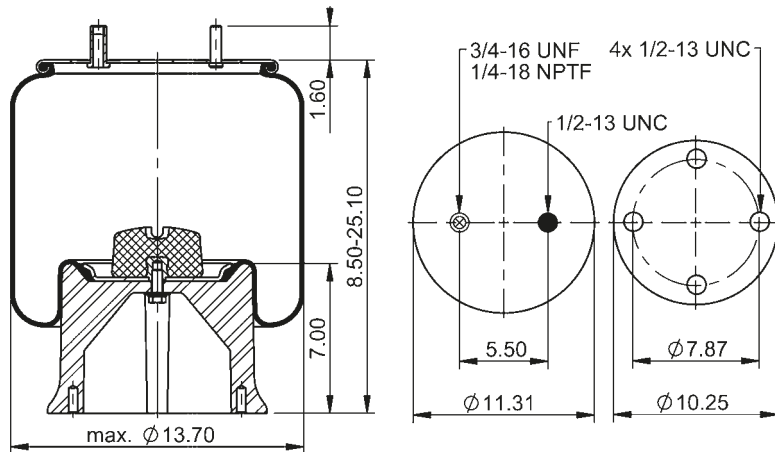

65360



**lb** 22.0 lb **No.** 9305215

**Cross-reference | Cruce de Referencia**  
Firestone W01-358-8781

**Manufacturer | Fabricante**  
Oshkosh 3620210  
SAF Holland 90557205

1/4-18 NPTF: max. 22 lb-ft  
1/2-13 UNC: max. 35 lb-ft  
3/4-16 UNF: max. 50 lb-ft

### 11 10.5-19 A 960

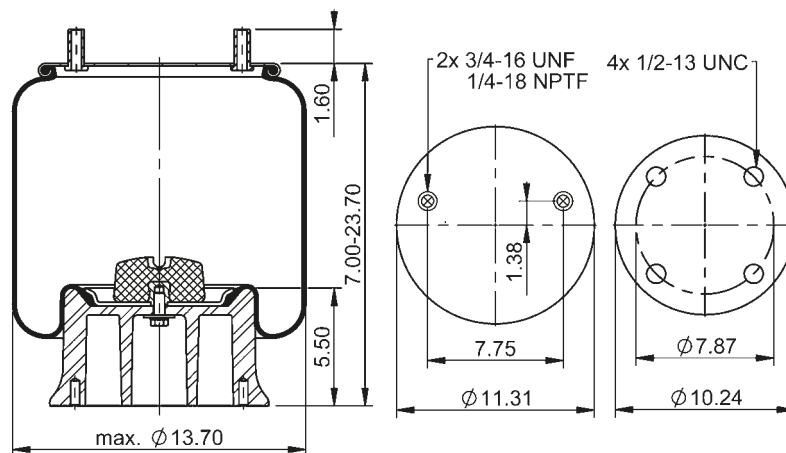

67547



**lb** 22.7 lb **No.** 9305216

**Cross-reference | Cruce de Referencia**  
Firestone W01-358-9804  
Goodyear 1R14-151

**Manufacturer | Fabricante**  
Ridewell 1000006

1/4-18 NPTF: max. 22 lb-ft  
1/2-13 UNC: max. 35 lb-ft  
3/4-16 UNF: max. 50 lb-ft

### 11 10.5-19 A 1047

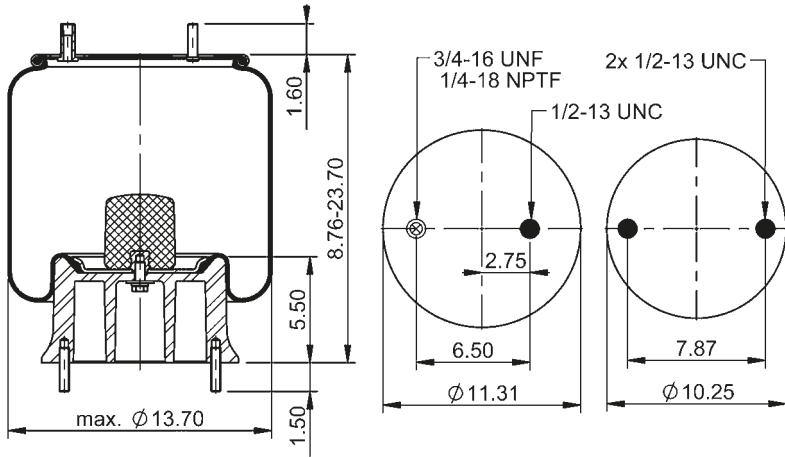

78166



**lb** 22.5 lb **No.** 9305216

**Manufacturer | Fabricante**  
SAF Holland 90557422

**1/4-18 NPTF:** max. 22 lb-ft  
**1/2-13 UNC:** max. 35 lb-ft  
**3/4-16 UNF:** max. 50 lb-ft

### 11 10.5-19 A 1069

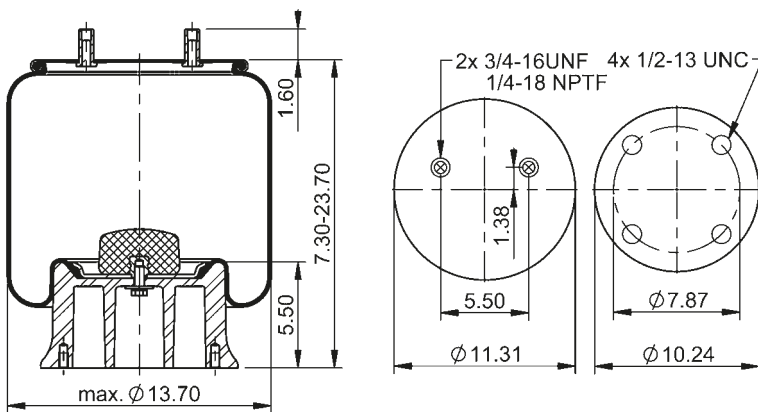

73833



**lb** 21.7 lb **No.** 9305216

**Cross-reference | Cruce de Referencia**  
Goodyear 1R14-209

**1/4-18 NPTF:** max. 22 lb-ft  
**1/2-13 UNC:** max. 35 lb-ft  
**3/4-16 UNF:** max. 50 lb-ft

### 11 10.5-19 A 1250

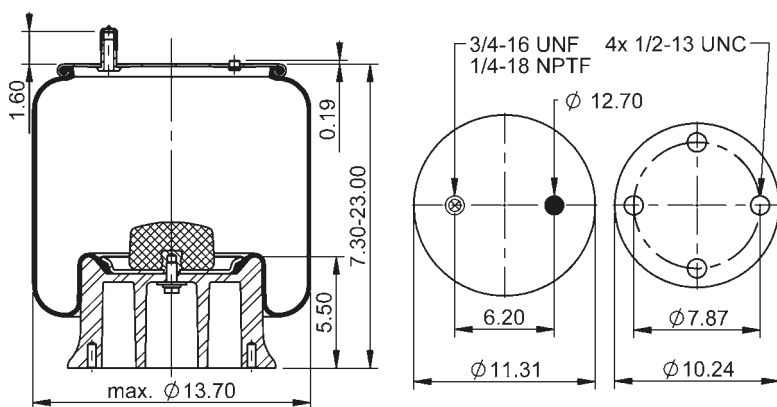

76150



**lb** 21.0 lb **No.** 9305216

**Cross-reference | Cruce de Referencia**  
Goodyear 1R14-234

**1/4-18 NPTF:** max. 22 lb-ft  
**1/2-13 UNC:** max. 35 lb-ft  
**3/4-16 UNF:** max. 50 lb-ft

### 11 10.5E-19 S 1320

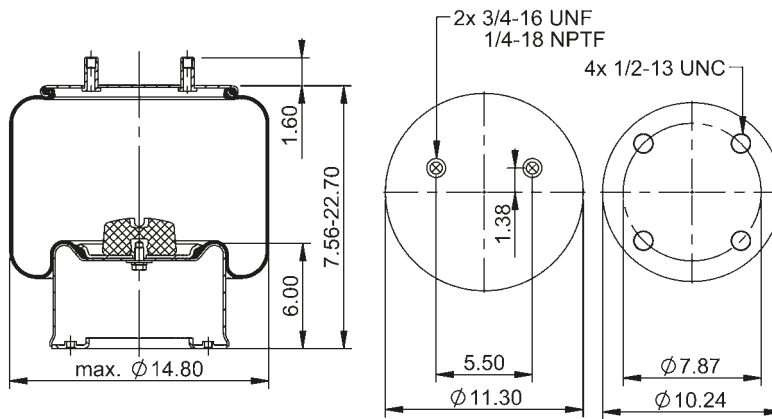

77833



**lb** 27.8 lb **No.** 9316272

**Cross-reference | Cruce de Referencia**  
Goodyear 1R14-232

**Manufacturer | Fabricante**  
Watson & Chalin AS-0241

**Wrench** 1/4-18 NPTF: max. 22 lb-ft  
1/2-13 UNC: max. 35 lb-ft  
3/4-16 UNF: max. 50 lb-ft

### 11 10.5-21 A 025

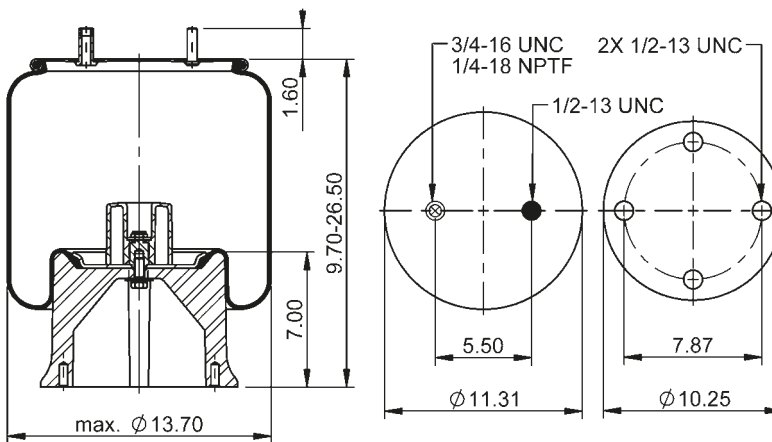

68010



**lb** 21.6 lb **No.** 9305215

**Cross-reference | Cruce de Referencia**  
Firestone W01-358-8764

**Manufacturer | Fabricante**  
SAF Holland 90557260

**Wrench** 1/4-18 NPTF: max. 22 lb-ft  
1/2-13 UNC: max. 35 lb-ft  
3/4-16 UNF: max. 50 lb-ft

### 11 10.5-21 A 062

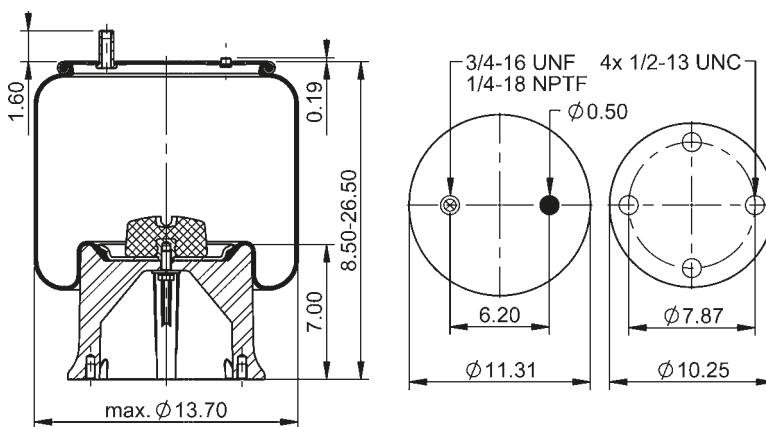

68589



**lb** 22.0 lb **No.** 9305215

**Cross-reference | Cruce de Referencia**  
Goodyear 1R14-154

**Manufacturer | Fabricante**  
Watson & Chalin AS-0023-1G

**Wrench** 1/4-18 NPTF: max. 22 lb-ft  
1/2-13 UNC: max. 35 lb-ft  
3/4-16 UNF: max. 50 lb-ft

### 11 10.5-21 A 219

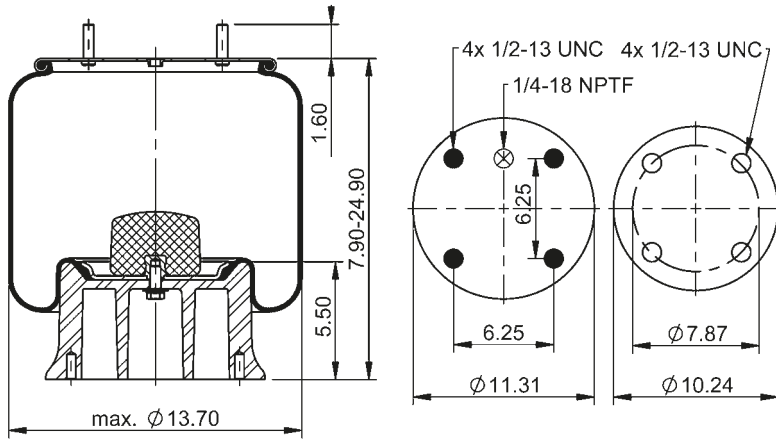

69746



**lb** 22.5 lb **No.** 9305216

**Cross-reference | Cruce de Referencia**  
Firestone W01-358-9201

1/4-18 NPTF: max. 18 lb-ft  
1/2-13 UNC: max. 35 lb-ft

### 11 10.5-21 A 313

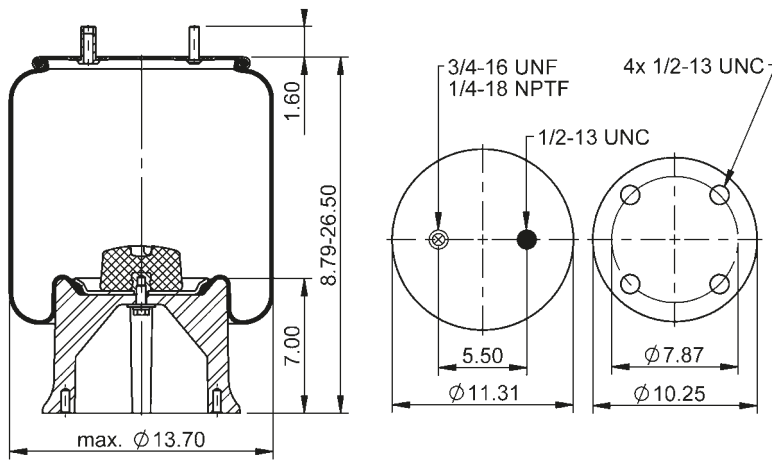

64273



**lb** 22.3 lb **No.** 9305215 11 10.5-21 A 026

**Cross-reference | Cruce de Referencia**  
Firestone W01-358-9122  
W01-358-8792  
Goodyear 1R14-045

**Manufacturer | Fabricante**  
Hendrickson S-3467  
S-3830  
S-12514-008  
S-12514-010

SAF Holland 90557020  
90557071  
90557076  
90557077

and more

1/4-18 NPTF: max. 22 lb-ft  
1/2-13 UNC: max. 35 lb-ft  
3/4-16 UNF: max. 50 lb-ft

### 11 10.5-21 A 318

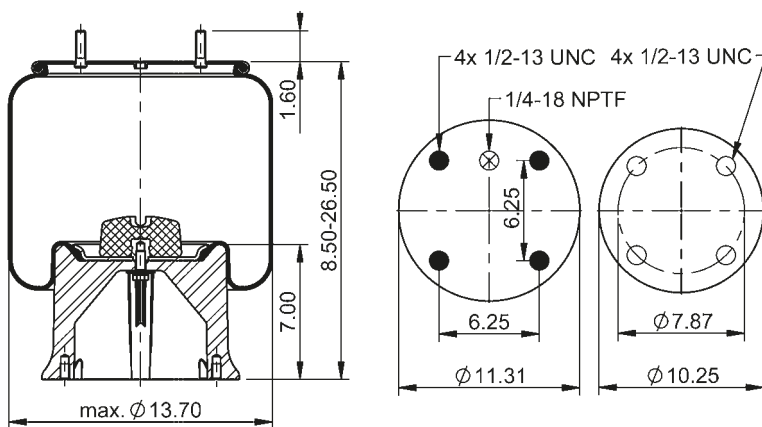

64352



**lb** 22.3 lb **No.** 9305215

**Cross-reference | Cruce de Referencia**  
Firestone W01-358-9158  
Goodyear 1R14-030

**Manufacturer | Fabricante**

Hendrickson S-2063  
S-12514-004  
S-12514-011

SAF Holland 90557005  
90557069  
90044197

Volvo 3130499  
Watson & Chalin AS-0124-F  
and more

1/4-18 NPTF: max. 22 lb-ft  
1/2-13 UNC: max. 35 lb-ft

### 11 10.5-21 A 370

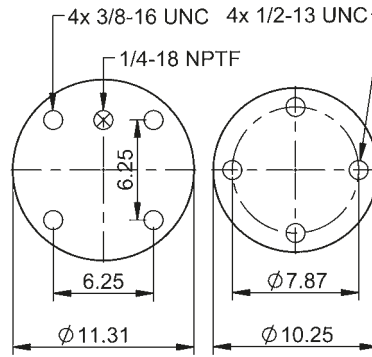
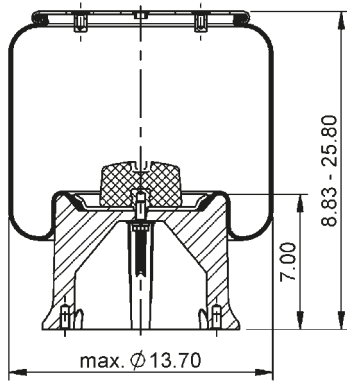

64354



**lb** 22.3 lb **No.** 9305215

**Cross-reference | Cruce de Referencia**  
 Firestone W01-358-9156  
 Goodyear 1R14-019

**Manufacturer | Fabricante**  
 Hendrickson S-7128  
 Navistar/Fleetrite 1681742C1  
 554777C1  
 Loadguard SC2111  
 SC2044  
 Peerless 0550-00081  
 0550-00080  
 Taurus AS622-9156

1/4-18 NPTF: max. 22 lb-ft  
 3/8-16 UNC: max. 20 lb-ft  
 1/2-13 UNC: max. 35 lb-ft

### 11 10.5-21 A 558

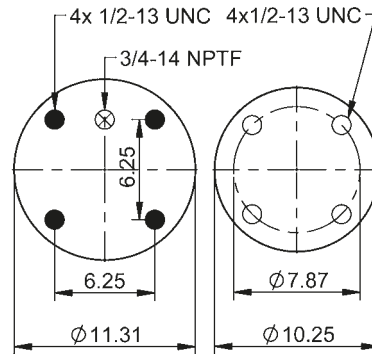
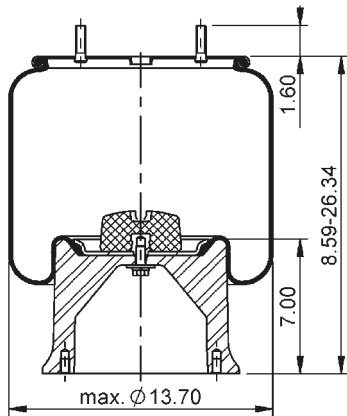

64356



**lb** 22.5 lb **No.** 9305215

**Cross-reference | Cruce de Referencia**  
 Firestone W01-358-9199

1/2-13 UNC: max. 35 lb-ft  
 3/4-14 NPTF: max. 22 lb-ft

### 11 10.5-21 A 855

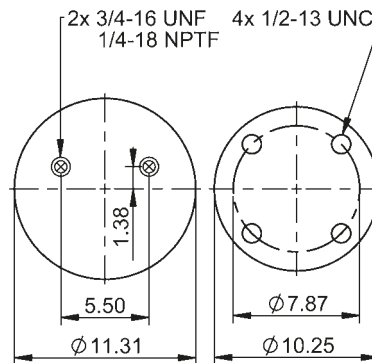
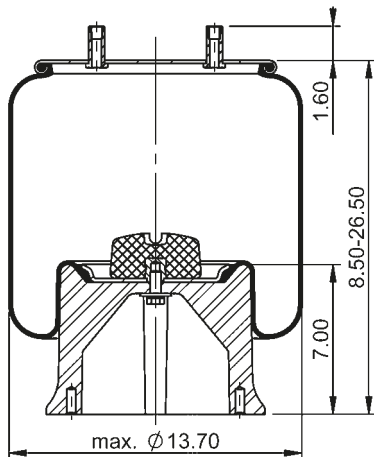

66084



**lb** 22.3 lb **No.** 9305215

**Manufacturer | Fabricante**  
 Watson & Chalin AS-0220

1/4-18 NPTF: max. 22 lb-ft  
 1/2-13 UNC: max. 35 lb-ft  
 3/4-16 UNF: max. 50 lb-ft

### 11 10.5-21 A 965

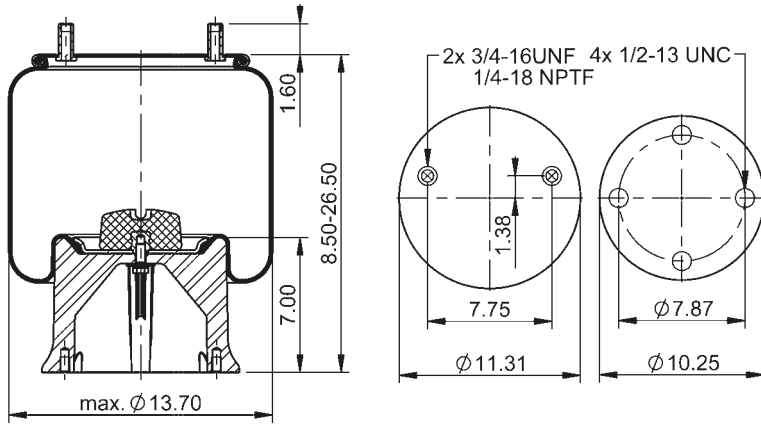

67625



**lb** 22.5 lb **No.** 9305215

**Cross-reference | Cruce de Referencia**  
Goodyear 1R14-201

**Wrench** 1/4-18 NPTF: max. 22 lb-ft  
1/2-13 UNC: max. 35 lb-ft  
3/4-16 UNF: max. 50 lb-ft

### 11 10.5-21 A 1339

**new**

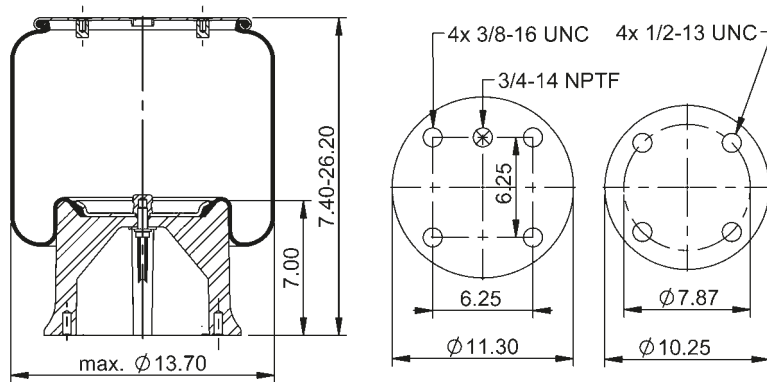

78046



**lb** 21.5 lb **No.** 9305215

**Cross-reference | Cruce de Referencia**  
Firestone W01-358-9153

**Wrench** 3/8-16 UNC: max. 14 lb-ft  
1/2-13 UNC: max. 25 lb-ft  
3/4-14 NPTF: max. 16 lb-ft

### 11 10.5D-21 S 788

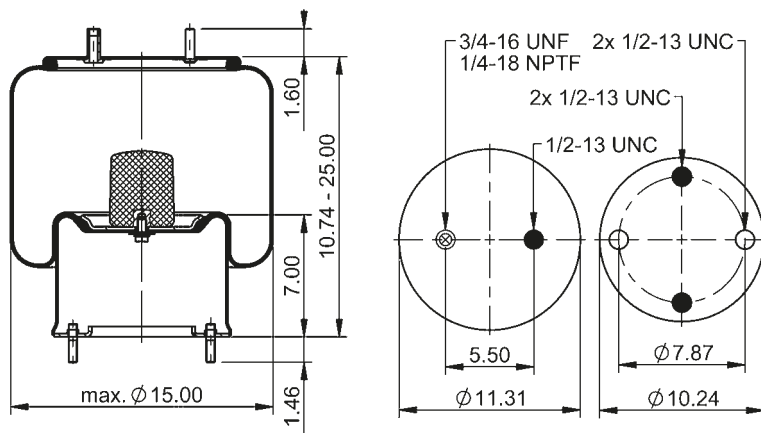

78170



**lb** 28.2 lb **No.** 9311048

**Manufacturer | Fabricante**  
SAF Holland 90557345

**Wrench** 1/4-18 NPTF: max. 22 lb-ft  
1/2-13 UNC: max. 35 lb-ft  
3/4-16 UNF: max. 50 lb-ft



### 11 10.5D-21 S 1063

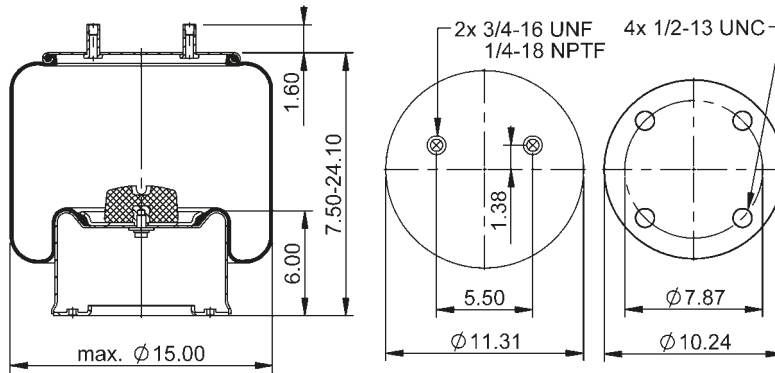

75269



**lb** 22.7 lb **No.** 9316272

**Cross-reference | Cruce de Referencia**  
Goodyear 1R14-152

**Manufacturer | Fabricante**  
Hendrickson C-25319

- 1/4-18 NPTF: max. 22 lb-ft
- 1/2-13 UNC: max. 35 lb-ft
- 3/4-16 UNF: max. 50 lb-ft

### 11 10.5-22 A 020

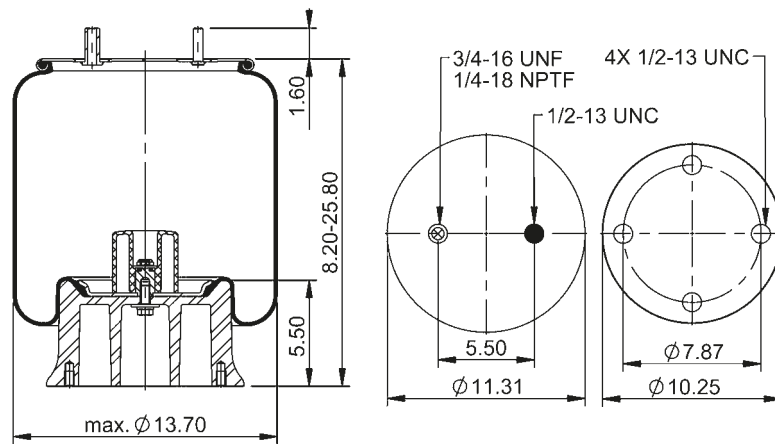

78333



**lb** 19.6 lb **No.** 9305216

**Manufacturer | Fabricante**  
SAF Holland 90557384

- 1/4-18 NPTF: max. 22 lb-ft
- 1/2-13 UNC: max. 35 lb-ft
- 3/4-16 UNF: max. 50 lb-ft

### 11 10.5-22 A 530

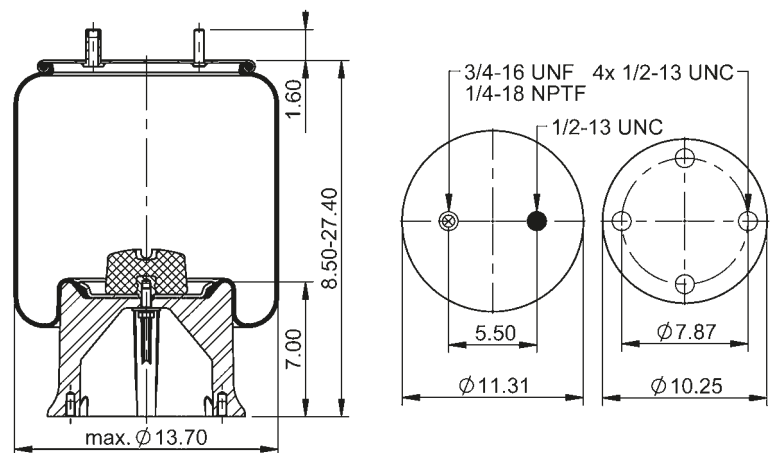

64422



**lb** 22.3 lb **No.** 9305215

**Cross-reference | Cruce de Referencia**  
Firestone W01-358-5503  
Goodyear 1R14-174

**Manufacturer | Fabricante**  
Meritor 200504  
SAF Holland 90557200  
Watson & Chalin AS-0047  
AS-0047-F

- 1/4-18 NPTF: max. 22 lb-ft
- 1/2-13 UNC: max. 35 lb-ft
- 3/4-16 UNF: max. 50 lb-ft

### 11 10.5-22 S 750

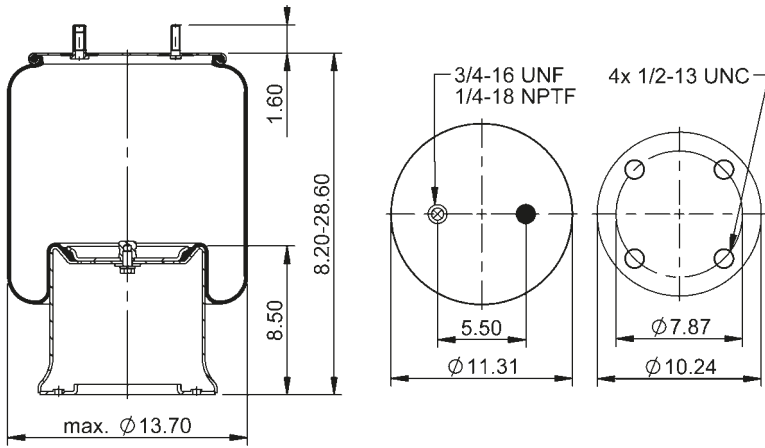

64688



**lb** 29.5 lb **No.** 9310291

**Cross-reference | Cruce de Referencia**

Firestone W01-358-5505  
Goodyear 1R14-113

**Manufacturer | Fabricante**

SAF Holland 90557103

- 1/4-18 NPTF: max. 22 lb-ft
- 1/2-13 UNC: max. 35 lb-ft
- 3/4-16 UNF: max. 50 lb-ft

### 11 10.5-22 A 752

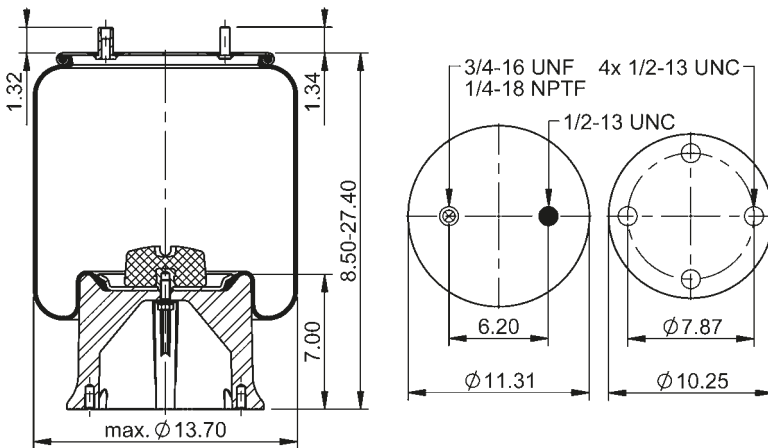

64690



**lb** 22.0 lb **No.** 9305215

**Cross-reference | Cruce de Referencia**

Firestone W01-358-5514  
Goodyear 1R14-170

**Manufacturer | Fabricante**

Watson & Chalin AS-0047-G  
AS-0047-1G

- 1/4-18 NPTF: max. 22 lb-ft
- 1/2-13 UNC: max. 35 lb-ft
- 3/4-16 UNF: max. 50 lb-ft

### 11 10.5-22 A 824

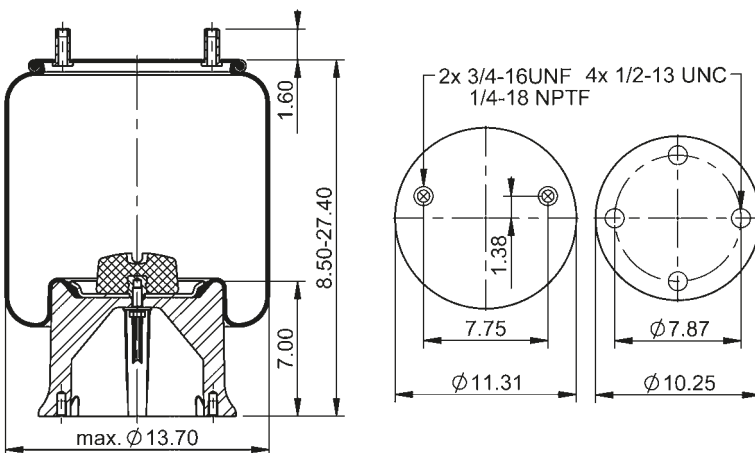

65772



**lb** 23.8 lb **No.** 9305215

**Manufacturer | Fabricante**

Watson & Chalin AS-0208

- 1/4-18 NPTF: max. 22 lb-ft
- 1/2-13 UNC: max. 35 lb-ft
- 3/4-16 UNF: max. 50 lb-ft

### 11 10.5-22 A 856

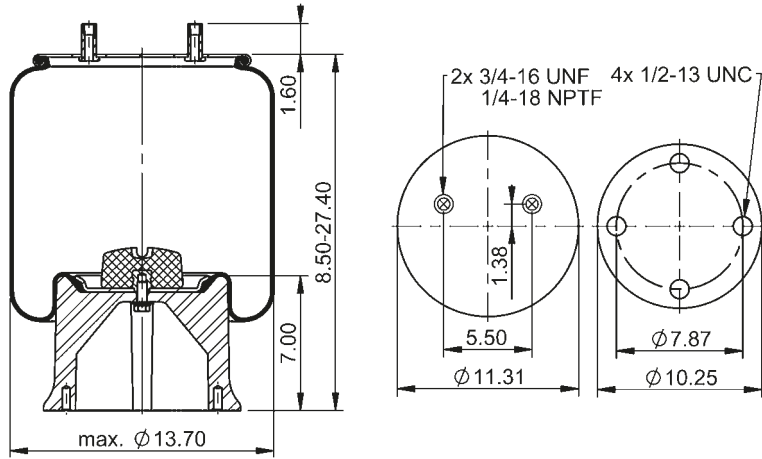

66085



**lb** 22.3 lb **No.** 9305215

**Manufacturer | Fabricante**  
Watson & Chalin AS-0221

**1/4-18 NPTF:** max. 22 lb-ft  
**1/2-13 UNC:** max. 35 lb-ft  
**3/4-16 UNF:** max. 50 lb-ft

### 11 10.5-22 A 931

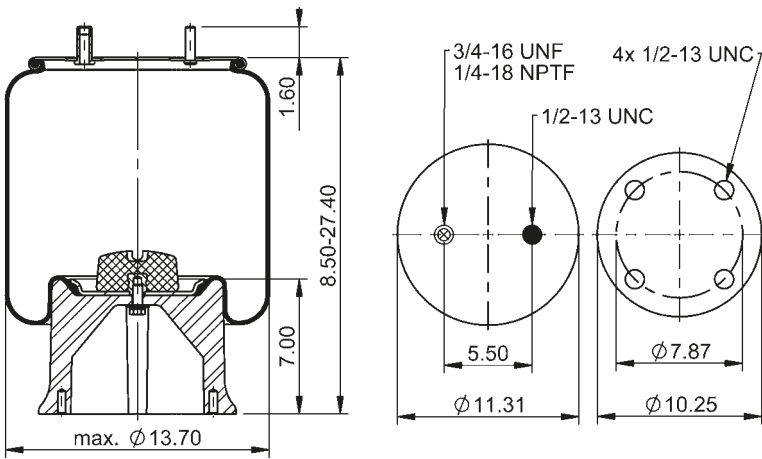

68159



**lb** 20.3 lb **No.** 9305215

**Cross-reference | Cruce de Referencia**  
Firestone W01-358-5511

**Manufacturer | Fabricante**  
Hendrickson S-22173  
SAF Holland 90557102

**1/4-18 NPTF:** max. 22 lb-ft  
**1/2-13 UNC:** max. 35 lb-ft  
**3/4-16 UNF:** max. 50 lb-ft

### 11 10.5-22 S 1009

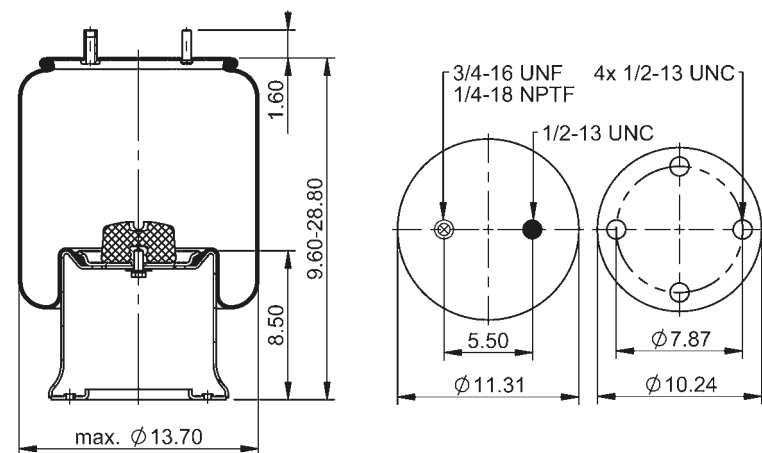

70771



**lb** 30.6 lb **No.** 9310291

**Cross-reference | Cruce de Referencia**  
Firestone W01-358-9891

**Manufacturer | Fabricante**  
SAF Holland 90557218

**1/4-18 NPTF:** max. 22 lb-ft  
**1/2-13 UNC:** max. 35 lb-ft  
**3/4-16 UNF:** max. 50 lb-ft

### 11 10.5-22 S 1199

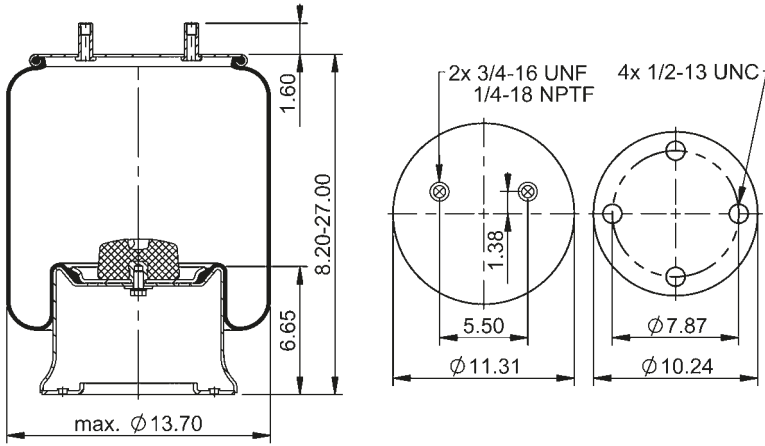

75465



**lb** 26.0 lb **No.** 9317652

**Cross-reference | Cruce de Referencia**  
 Goodyear 1R14-149  
 1R14-240

**Manufacturer | Fabricante**  
 Hendrickson C-24445

**1/4-18 NPTF:** max. 22 lb-ft  
**1/2-13 UNC:** max. 35 lb-ft  
**3/4-16 UNF:** max. 50 lb-ft

### 11 10.5-22 S 1221

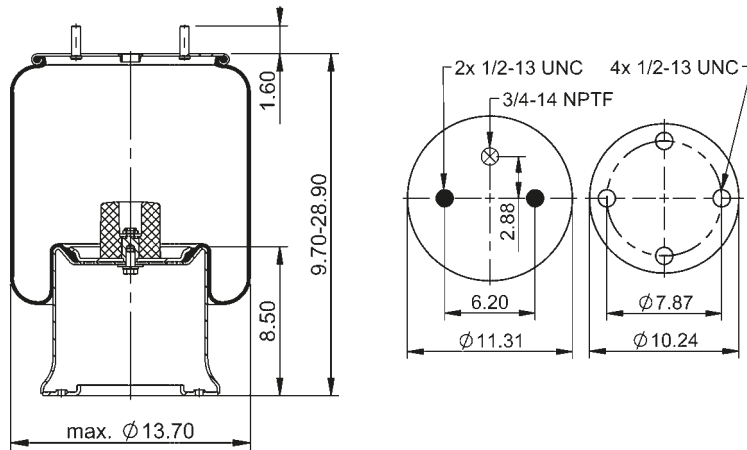

78237



**lb** 19.4 lb **No.** 9310291

**Manufacturer | Fabricante**  
 Hendrickson C-24774

**1/2-13 UNC:** max. 35 lb-ft  
**3/4-14 NPTF:** max. 22 lb-ft

### 11 10.5-24 S 276

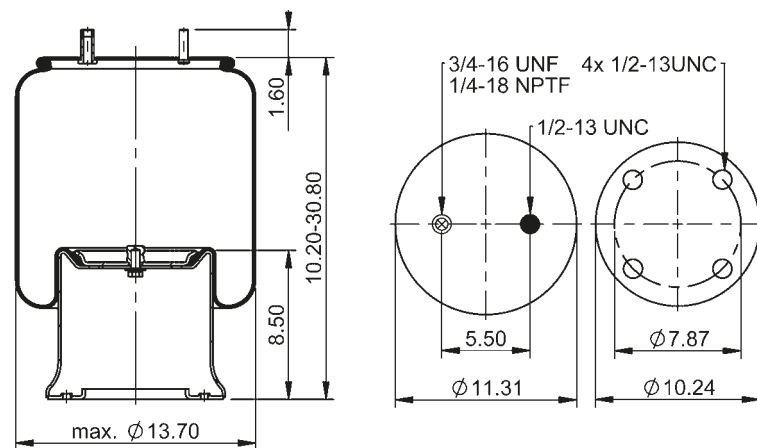

70118



**lb** 31.3 lb **No.** 9310291

**Cross-reference | Cruce de Referencia**  
 Firestone W01-358-9915

**Manufacturer | Fabricante**  
 SAF Holland 90557104  
 Watson & Chalin AS-0063

**1/4-18 NPTF:** max. 22 lb-ft  
**1/2-13 UNC:** max. 35 lb-ft  
**3/4-16 UNF:** max. 50 lb-ft

### 11 10.5-24 S 277

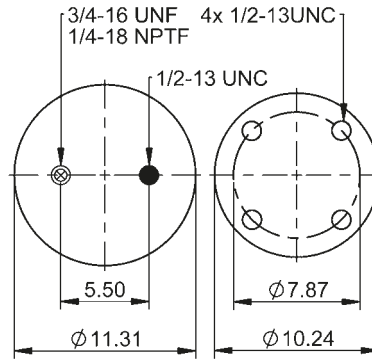
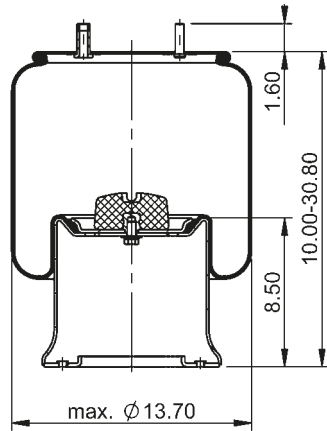

70119



**lb** 31.3 lb **No.** 9310291

**Cross-reference | Cruce de Referencia**  
Firestone W01-358-9929

**Manufacturer | Fabricante**  
SAF Holland 90557106  
Watson & Chalin AS-0099

1/4-18 NPTF: max. 22 lb-ft  
1/2-13 UNC: max. 35 lb-ft  
3/4-16 UNF: max. 50 lb-ft

### 11 10.5-24 S 712

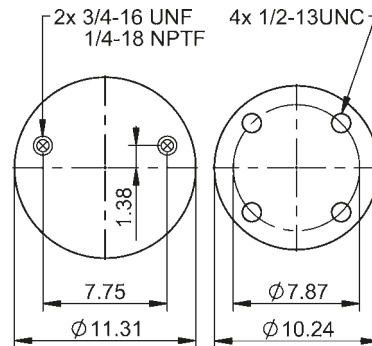
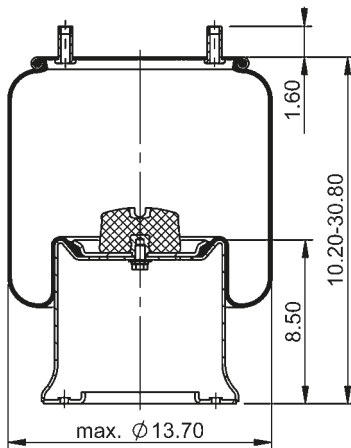

64637



**lb** 31.1 lb **No.** 9310291

**Cross-reference | Cruce de Referencia**  
Firestone W01-358-9264  
Goodyear 1R14-127

**Manufacturer | Fabricante**  
Hendrickson S-13122  
Ridewell 1000002

1/4-18 NPTF: max. 22 lb-ft  
1/2-13 UNC: max. 35 lb-ft  
3/4-16 UNF: max. 50 lb-ft

### 11 10.5-24 S 1200

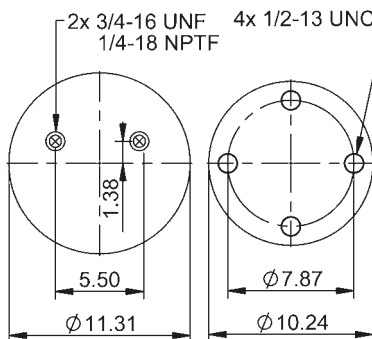
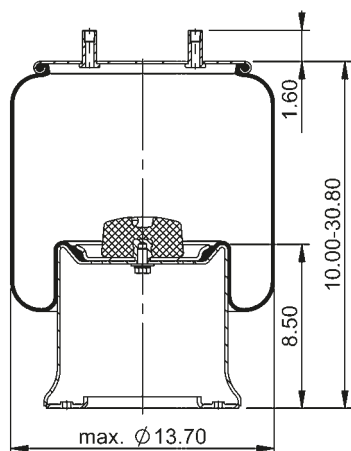

75464



**lb** 31.1 lb **No.** 9310291

**Cross-reference | Cruce de Referencia**  
Goodyear 1R14-148  
1R14-236

**Manufacturer | Fabricante**  
Hendrickson C-24446  
Watson & Chalin AS-0246

1/4-18 NPTF: max. 22 lb-ft  
1/2-13 UNC: max. 35 lb-ft  
3/4-16 UNF: max. 50 lb-ft



# Single Convoluted Air Springs

Bolsas de Aire de Una Cámara



Single Convoluted Air Springs |  
Bolsas de Aire de Una Cámara

### FS 330-11 467

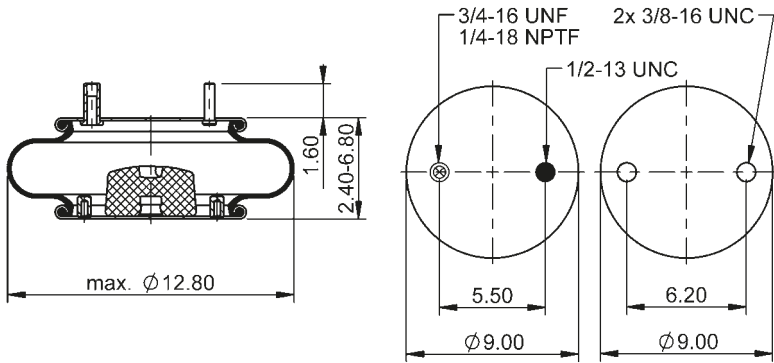

64594



**lb** 10.2 lb

**Cross-reference | Cruce de Referencia**

Firestone	W01-358-6994
Goodyear	1B12-322

**Manufacturer | Fabricante**

Brake & Wheel	M3527
---------------	-------

- 1/4-18 NPTF: max. 22 lb-ft
- 3/8-16 UNC: max. 20 lb-ft
- 3/4-16 UNF: max. 50 lb-ft

### FS 330-11 468

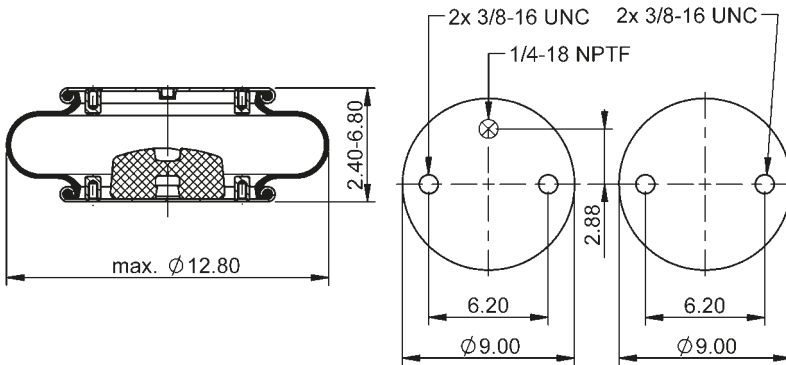

64595



**lb** 10.1 lb

**Cross-reference | Cruce de Referencia**

Firestone	W01-358-7009
Goodyear	1B12-301

**Manufacturer | Fabricante**

Ridewell	1003587009C
SAF Holland	90557002

- 1/4-18 NPTF: max. 22 lb-ft
- 3/8-16 UNC: max. 20 lb-ft

### FS 330-11 474

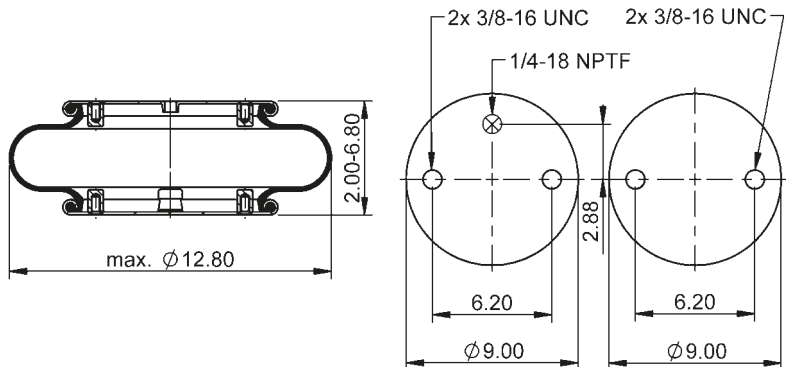

64596



**lb** 8.9 lb

**Cross-reference | Cruce de Referencia**

Firestone	W01-358-7008
Goodyear	1B12-313

**Manufacturer | Fabricante**

Loadguard	SC2010
SAF Holland	90557226
Watson & Chalin	AS-0149-1G

- 1/4-18 NPTF: max. 22 lb-ft
- 3/8-16 UNC: max. 20 lb-ft



### FS 330-11 771

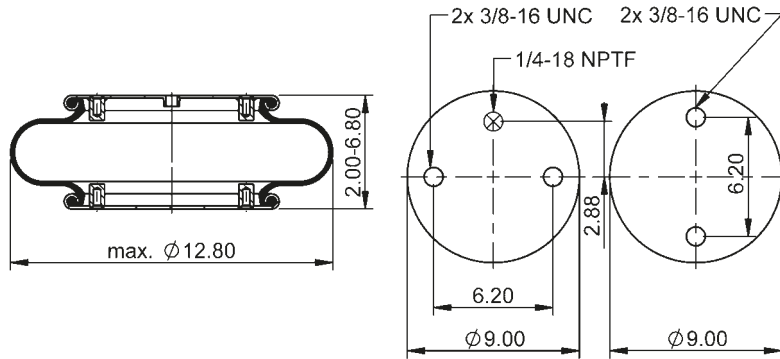

66091



**lb** 9.3 lb

**Manufacturer | Fabricante**  
Strong 72404004

**1/4-18 NPTF:** max. 22 lb-ft  
**3/8-16 UNC:** max. 20 lb-ft

### FS 530-14 339

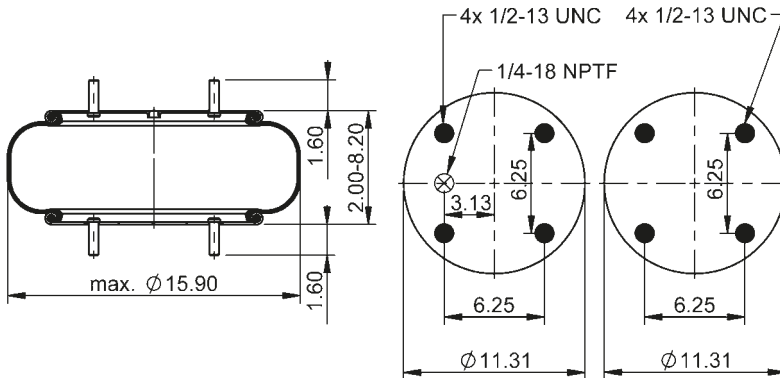

64521



**lb** 13.2 lb

**Cross-reference | Cruce de Referencia**  
Firestone W01-358-7112  
Goodyear 1B14-358

**Manufacturer | Fabricante**  
Granning 6419  
Hendrickson S-13044  
Loadguard SC2012  
Navistar/Fleetrite 554782C1  
Ridewell 1003587112C  
SAF Holland 90557026  
90557028  
90557041

and more  
**1/4-18 NPTF:** max. 22 lb-ft  
**1/2-13 UNC:** max. 35 lb-ft

### FS 530-14 361

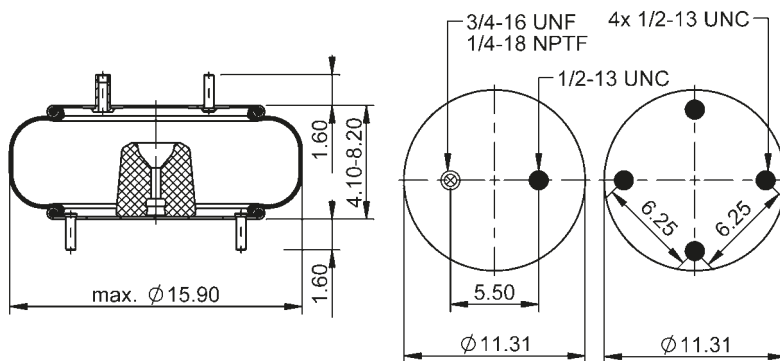

64522



**lb** 15.2 lb

**Cross-reference | Cruce de Referencia**  
Firestone W01-358-7117

**1/4-18 NPTF:** max. 22 lb-ft  
**1/2-13 UNC:** max. 35 lb-ft  
**3/4-16 UNF:** max. 50 lb-ft

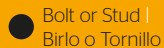

Bolt or Stud | Birlo o Tornillo



Hole | Tuerca Ciega



Combination Stud | Combinación de Entrada de Aire y Birlo



Air Inlet | Entrada de Aire

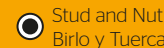

Stud and Nut | Birlo y Tuerca

### FS 530-14 442

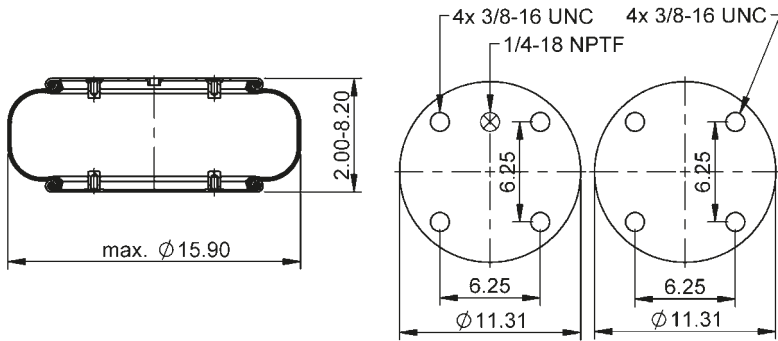

64523



**lb** 12.9 lb

**Cross-reference | Cruce de Referencia**

Firestone	W01-358-7103
Goodyear	1B14-350

**Manufacturer | Fabricante**

Peerless	0550-00015
----------	------------

1/4-18 NPTF: max. 22 lb-ft  
3/8-16 UNC: max. 20 lb-ft

### FS 530-14 446

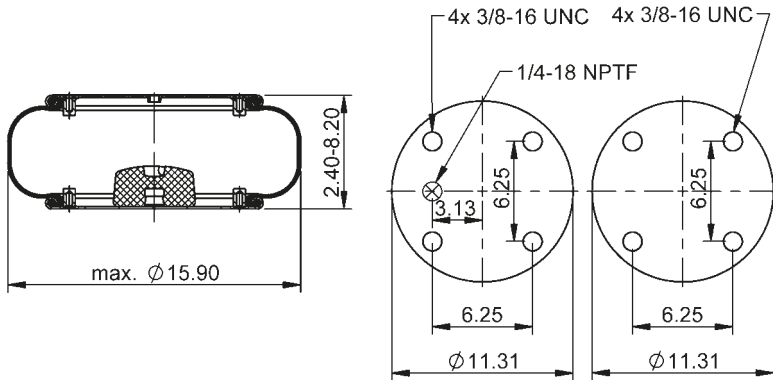

64524



**lb** 14.2 lb

**Cross-reference | Cruce de Referencia**

Firestone	W01-358-7104
-----------	--------------

**Manufacturer | Fabricante**

Ridewell	1003587104C
----------	-------------

1/4-18 NPTF: max. 22 lb-ft  
3/8-16 UNC: max. 20 lb-ft

### FS 530-14 447

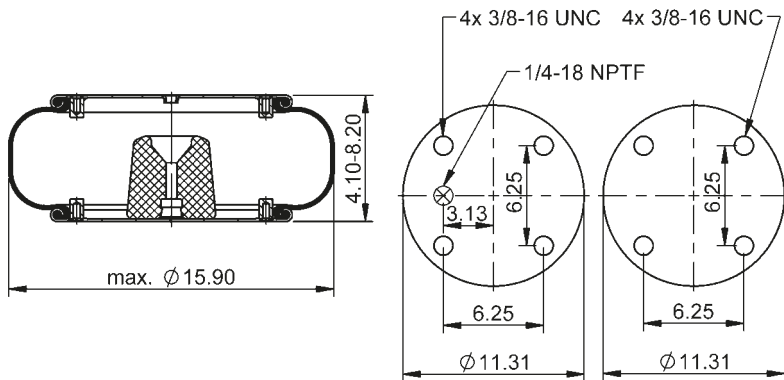

64525



**lb** 15.1 lb

**Cross-reference | Cruce de Referencia**

Firestone	W01-358-7105
Goodyear	1B14-351

**Manufacturer | Fabricante**

American Carrier	8003-007
------------------	----------

1/4-18 NPTF: max. 22 lb-ft  
3/8-16 UNC: max. 20 lb-ft

### FS 530-14 515

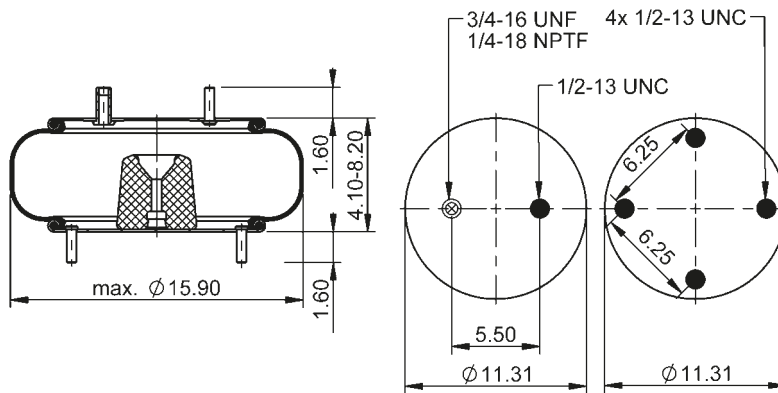

64526



15.2 lb

**Cross-reference | Cruce de Referencia**  
Firestone W01-358-7093

**Manufacturer | Fabricante**  
American Carrier 8003-013

1/4-18 NPTF: max. 22 lb-ft  
1/2-13 UNC: max. 35 lb-ft  
3/4-16 UNF: max. 50 lb-ft

### FS 530-14 516

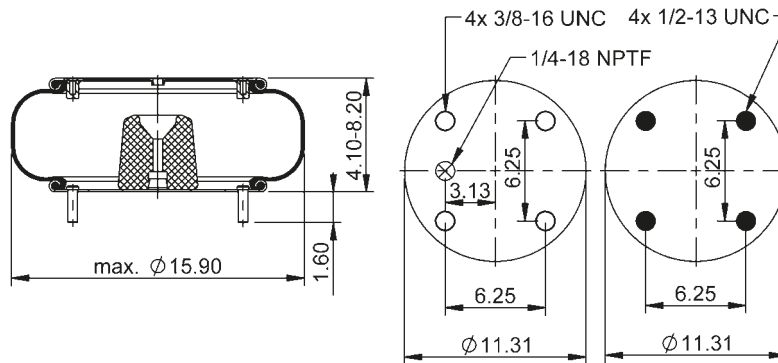

64527



15.2 lb

**Cross-reference | Cruce de Referencia**  
Firestone W01-358-7096

**Manufacturer | Fabricante**  
Meritor 200807  
200792  
Seats 200807  
Suspensions, Inc. 200792

1/4-18 NPTF: max. 22 lb-ft  
3/8-16 UNC: max. 20 lb-ft  
1/2-13 UNC: max. 35 lb-ft

### FS 530-14 517

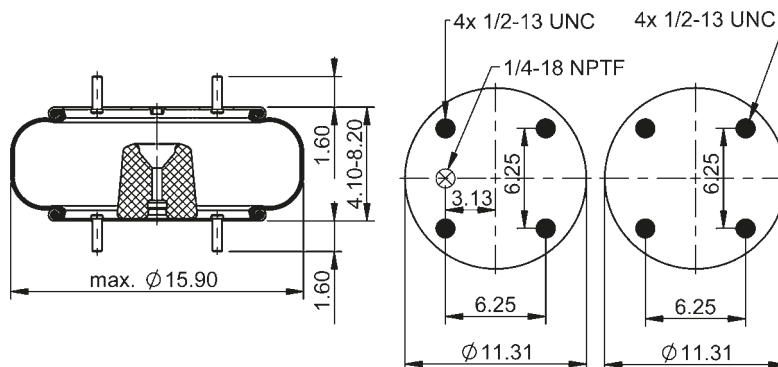

64528



15.4 lb

**Cross-reference | Cruce de Referencia**  
Firestone W01-358-7088

**Manufacturer | Fabricante**  
Meritor 200175  
Seats  
Suspensions, Inc.

1/4-18 NPTF: max. 22 lb-ft  
1/2-13 UNC: max. 35 lb-ft

# FS 530-14 538

64529

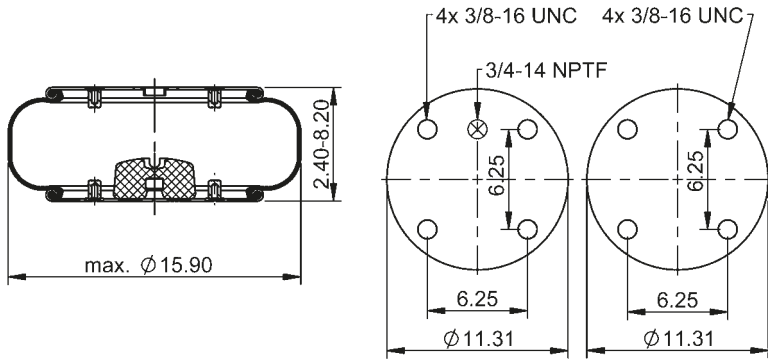

**lb** 14.4 lb

**Cross-reference | Cruce de Referencia**  
 Firestone W01-358-7094

3/8-16 UNC: max. 20 lb-ft  
 3/4-14 NPTF: max. 22 lb-ft

# Double Convoluted Air Springs

Bolsas de Aire de Dos Cámaras



Double Convoluted Air Springs  
Bolsas de Aire de Dos Cámaras

### FD 70-13 796

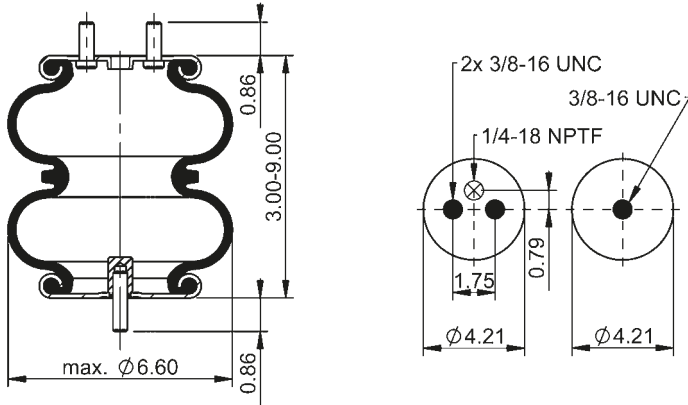

66660



3.3 lb

**Cross-reference | Cruce de Referencia**  
Firestone W01-358-6761

**Manufacturer | Fabricante**  
Lippert 156425

1/4-18 NPTF: max. 22 lb-ft  
3/8-16 UNC: max. 20 lb-ft

### FD 70-13 918

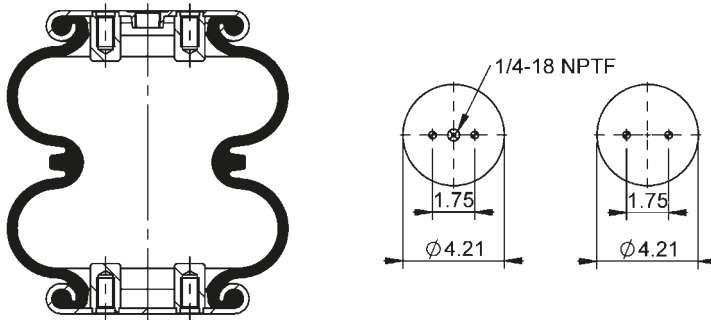

73310



3.4 lb

**Cross-reference | Cruce de Referencia**  
Firestone W01-358-7025

1/4-18 NPTF: max. 18 lb-ft

### FD 70-15 733

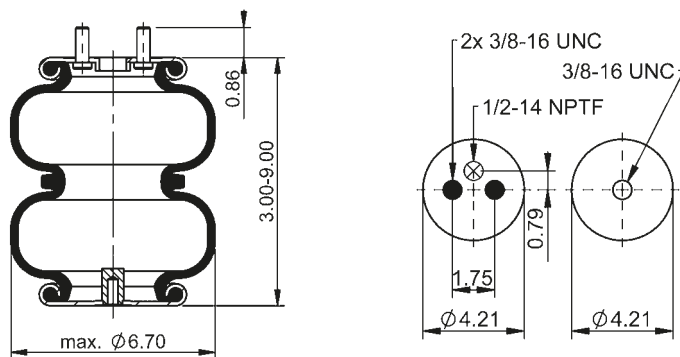

64730



3.7 lb

**Manufacturer | Fabricante**  
MAC 2380 Z1-0

3/8-16 UNC: max. 20 lb-ft  
1/2-14 NPTF: max. 22 lb-ft

### FD 70-15 738

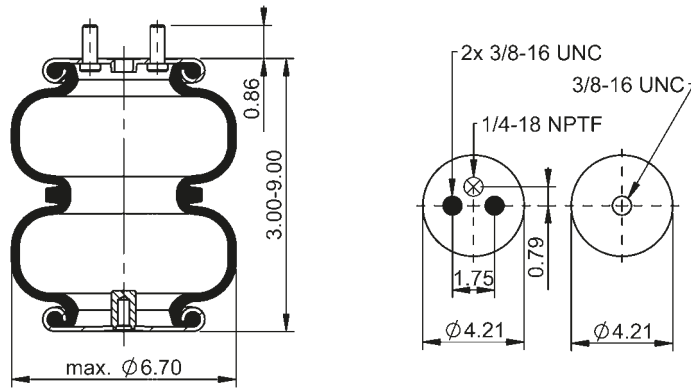

64735



**lb** 3.3 lb

**Cross-reference | Cruce de Referencia**  
Firestone W21-760-6781

**Manufacturer | Fabricante**  
MAC 2380 Z1 1/4

1/4-18 NPTF: max. 22 lb-ft  
3/8-16 UNC: max. 20 lb-ft

### FD 70-15 740

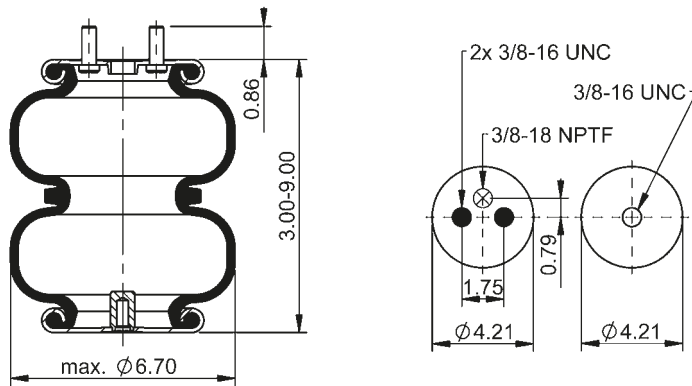

64737



**lb** 3.7 lb

**Manufacturer | Fabricante**  
MAC 2380 Z1 3/8

3/8-16 UNC: max. 20 lb-ft  
3/8-18 NPTF: max. 20 lb-ft

### FD 70-15 742 (4ply)

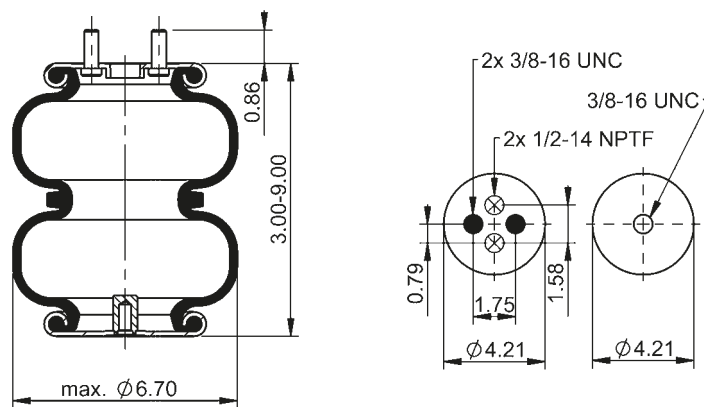

64739



**lb** 4.2 lb 4 PLY

**Manufacturer | Fabricante**  
MAC 2380 Z43

3/8-16 UNC: max. 20 lb-ft  
1/2-14 NPTF: max. 22 lb-ft

### FD 70-15 744 (4ply)

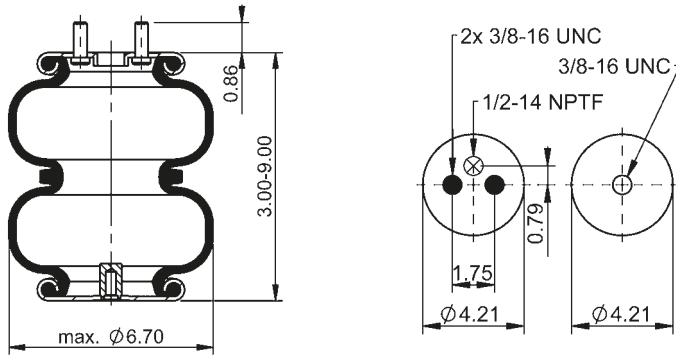

64741



**lb** 4.2 lb **No.** 4 PLY

**Manufacturer | Fabricante**

MAC 2380 Z41

3/8-16 UNC: max. 20 lb-ft  
1/2-14 NPTF: max. 22 lb-ft

### FD 70-17 820

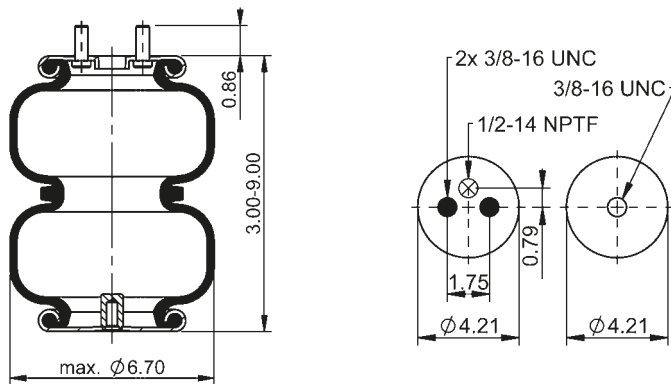

67700



**lb** 3.3 lb

**Manufacturer | Fabricante**

MAC 2380 Z1

3/8-16 UNC: max. 20 lb-ft  
1/2-14 NPTF: max. 22 lb-ft

### FD 110-15 734

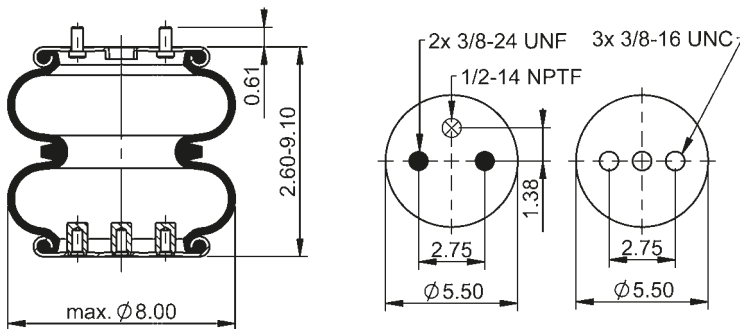

64731



**lb** 4.9 lb

**Manufacturer | Fabricante**

MAC 2380 Z2-0

3/8-16 UNC: max. 20 lb-ft  
1/2-14 NPTF: max. 22 lb-ft



### FD 110-15 735

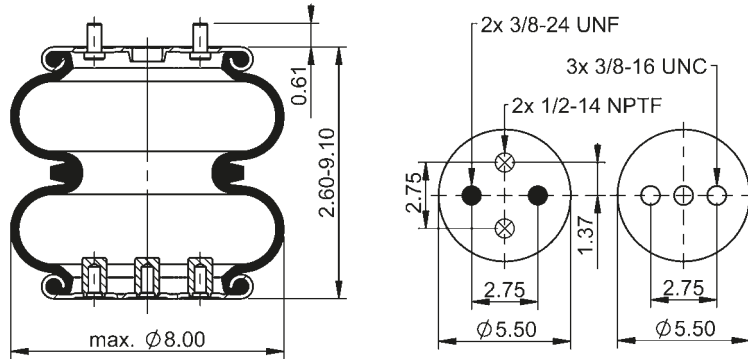

64732



4.8 lb

Manufacturer | Fabricante  
MAC 2380 Z5

3/8-16 UNC: max. 20 lb-ft  
1/2-14 NPTF: max. 22 lb-ft

### FD 110-15 737

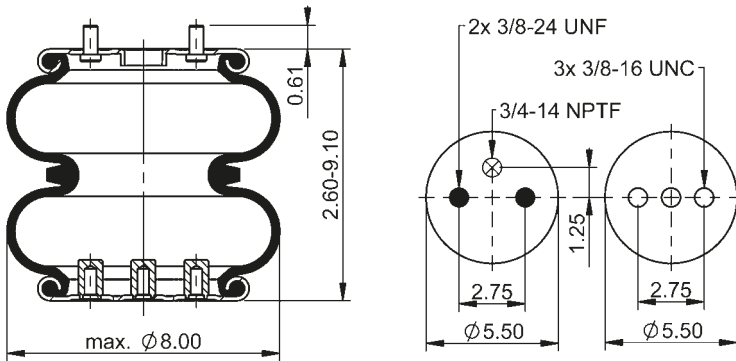

64734



4.8 lb

Manufacturer | Fabricante  
MAC 2380 Z9

3/8-16 UNC: max. 20 lb-ft  
3/4-14 NPTF: max. 22 lb-ft

### FD 110-15 739

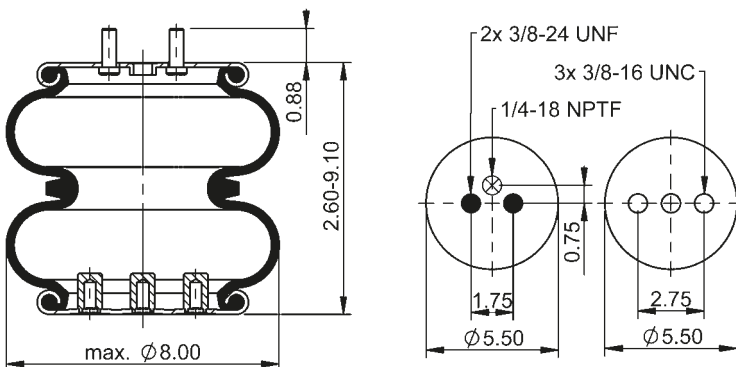

64736



4.6 lb

Manufacturer | Fabricante  
MAC 2380 Z2 1/4

1/4-18 NPTF: max. 22 lb-ft  
3/8-16 UNC: max. 20 lb-ft

### FD 110-15 741

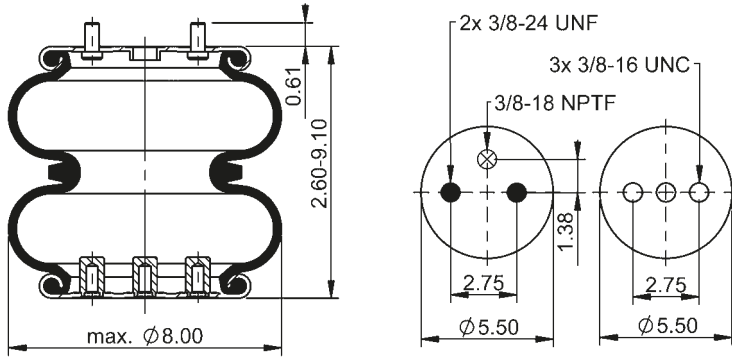

64738



4.6 lb

Manufacturer | Fabricante

MAC 2380 Z2 3/8

3/8-16 UNC: max. 20 lb-ft  
3/8-18 NPTF: max. 20 lb-ft

### FD 110-15 743 (4ply)

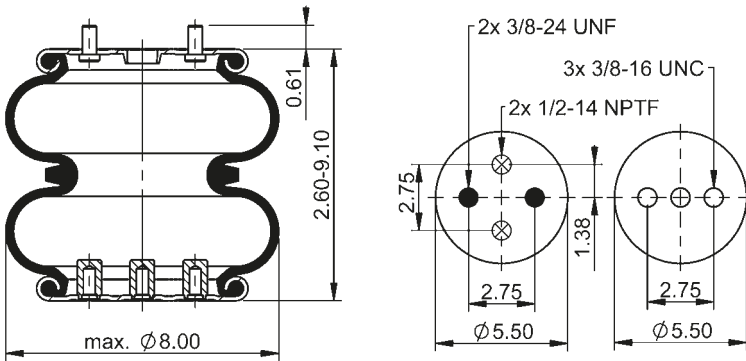

64740



5.4 lb 4 PLY

Manufacturer | Fabricante

MAC 2380 Z44

3/8-16 UNC: max. 20 lb-ft  
1/2-14 NPTF: max. 22 lb-ft

### FD 110-15 745 (4ply)

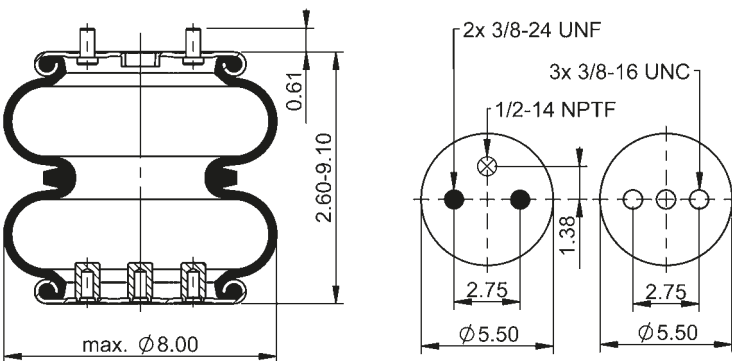

64742



5.2 lb 4 PLY

Manufacturer | Fabricante

MAC 2380 Z42

3/8-16 UNC: max. 20 lb-ft  
1/2-14 NPTF: max. 22 lb-ft

### FD 110-15 746 (4ply)

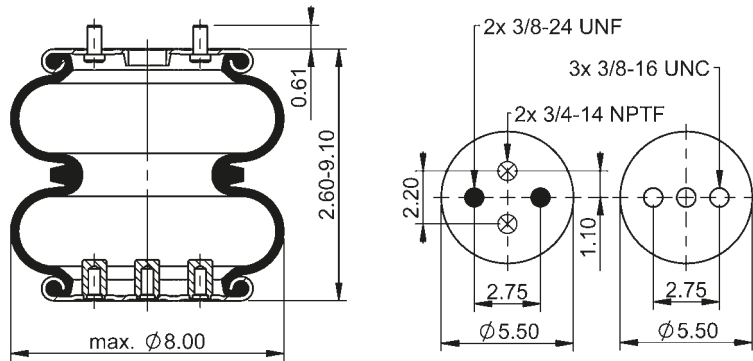

64743



**lb** 5.3 lb **No.** 4 PLY

**Manufacturer | Fabricante**  
MAC 2380 Z45

**3/8-16 UNC: max. 20 lb-ft**  
**3/4-14 NPTF: max. 22 lb-ft**

### FD 110-15 758

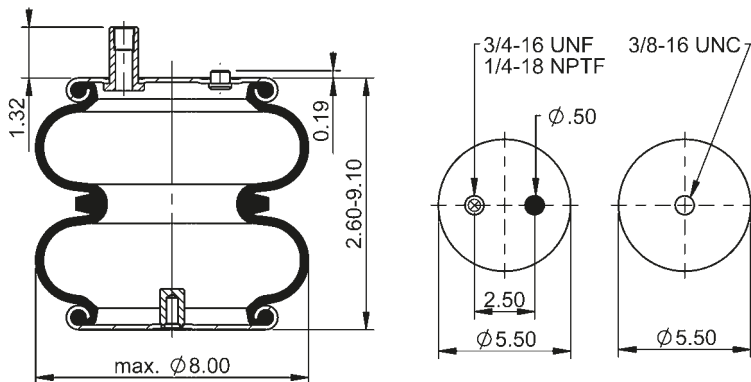

65391



**lb** 4.5 lb

**Cross-reference | Cruce de Referencia**  
Firestone W21-760-6401

**1/4-18 NPTF: max. 22 lb-ft**  
**3/8-16 UNC: max. 20 lb-ft**  
**3/4-16 UNF: max. 50 lb-ft**

### FD 110-15 763

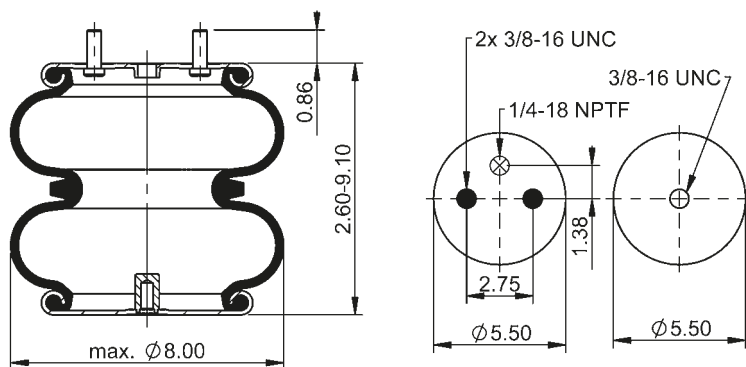

66092



**lb** 5.0 lb

**Cross-reference | Cruce de Referencia**  
Firestone W21-760-6873

**1/4-18 NPTF: max. 22 lb-ft**  
**3/8-16 UNC: max. 20 lb-ft**

### FD 110-15 766

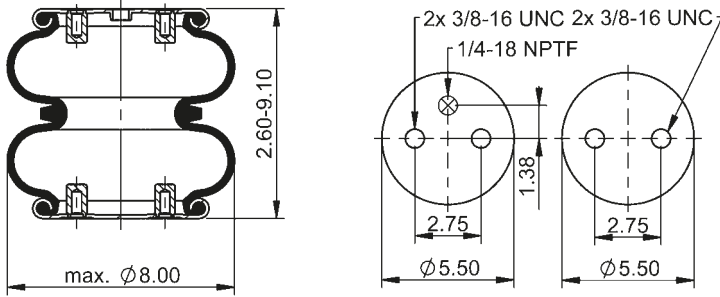

66094



**lb** 4.4 lb

**Cross-reference | Cruce de Referencia**

Goodyear 2B6-535

**Manufacturer | Fabricante**

Load Air P10-754-U

1/4-18 NPTF: max. 22 lb-ft  
3/8-16 UNC: max. 20 lb-ft

### FD 110-17A 775

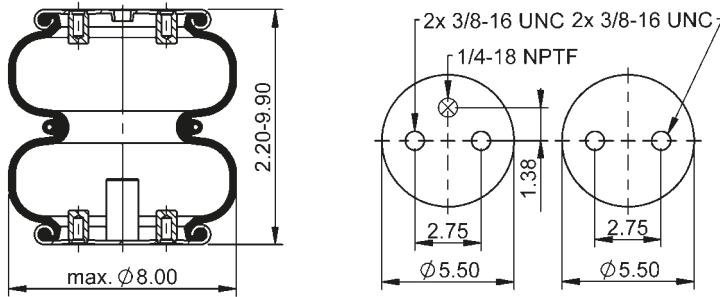

67667



**lb** 5.1 lb

**Cross-reference | Cruce de Referencia**

Firestone W01-358-7659  
Goodyear 2B7-548

**Manufacturer | Fabricante**

Hendrickson 5079

1/4-18 NPTF: max. 22 lb-ft  
3/8-16 UNC: max. 20 lb-ft

### FD 110-17A 789

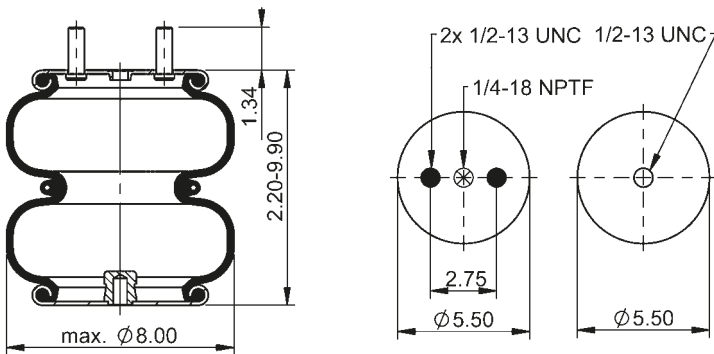

67553



**lb** 5.5 lb

**Cross-reference | Cruce de Referencia**

Firestone W01-358-7505

**Manufacturer | Fabricante**

Hendrickson 1347

1/4-18 NPTF: max. 22 lb-ft  
1/2-13 UNC: max. 35 lb-ft

### FD 110-17A 804

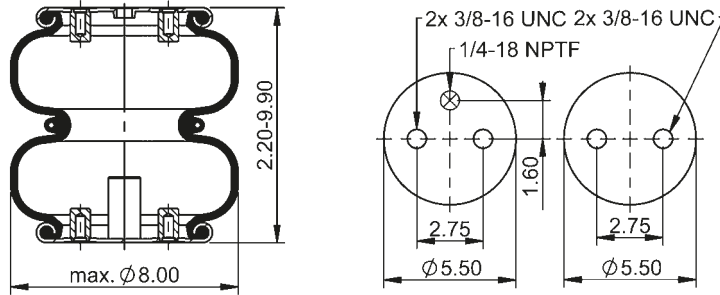

68160



5.2 lb

**Manufacturer | Fabricante**  
Hendrickson 5079

1/4-18 NPTF: max. 22 lb-ft  
3/8-16 UNC: max. 20 lb-ft

### FD 110-19 815

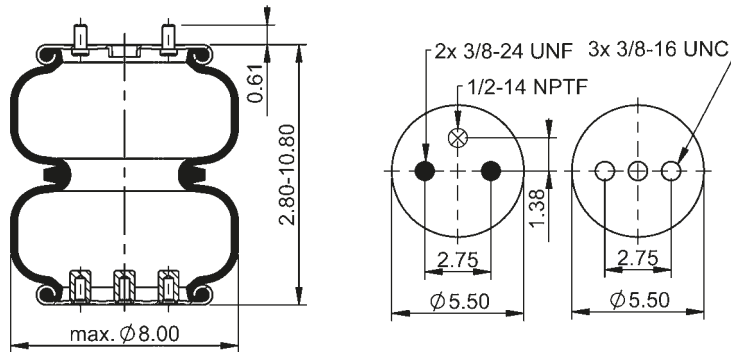

67602



4.9 lb

**Manufacturer | Fabricante**  
MAC 2380 Z2

3/8-16 UNC: max. 20 lb-ft  
1/2-14 NPTF: max. 22 lb-ft

### FD 120-20 509

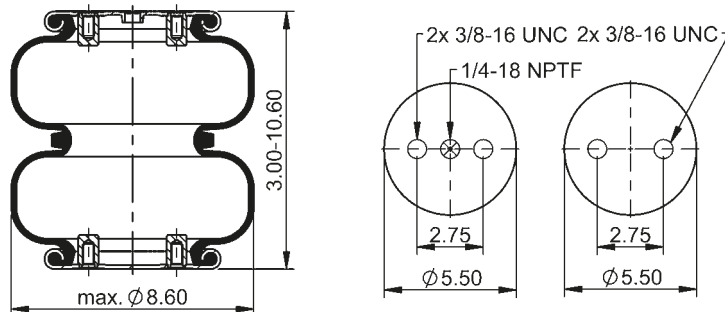

64601



5.0 lb

**Cross-reference | Cruce de Referencia**  
Firestone W01-358-7325  
Goodyear 2B8-550

**Manufacturer | Fabricante**  
American Carrier 8003-006  
Hendrickson S-14395  
Loadguard SC2751  
Mack 227QS32  
57QK1113  
SAF Holland 57007325  
Sauer P10-754  
Watson & Chalin AS-0030

1/4-18 NPTF: max. 22 lb-ft  
3/8-16 UNC: max. 20 lb-ft

### FD 120-20 715

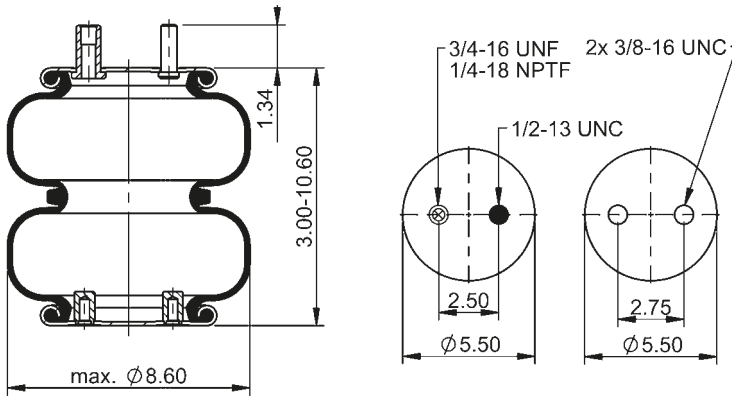

64666



5.1 lb

**Cross-reference | Cruce de Referencia**  
Firestone W01-358-7705

**Manufacturer | Fabricante**  
Watson & Chalin AS-0068

1/4-18 NPTF: max. 22 lb-ft  
3/8-16 UNC: max. 20 lb-ft  
3/4-16 UNF: max. 50 lb-ft

### FD 120-20 736

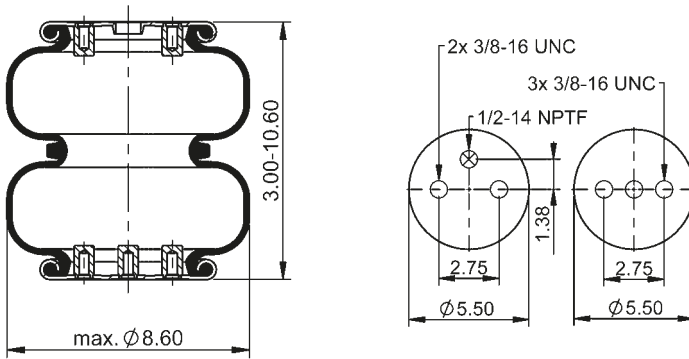

64733



4.6 lb

**Manufacturer | Fabricante**  
MAC 2380 Z7

3/8-16 UNC: max. 20 lb-ft  
1/2-14 NPTF: max. 22 lb-ft

### FD 120-20 795

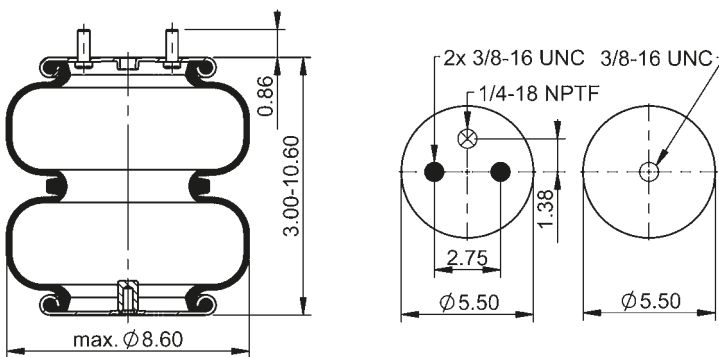

66661



5.3 lb

**Cross-reference | Cruce de Referencia**  
Firestone W01-358-7689

**Manufacturer | Fabricante**  
Lippert 156622

1/4-18 NPTF: max. 22 lb-ft  
3/8-16 UNC: max. 20 lb-ft

### FD 200-19 310

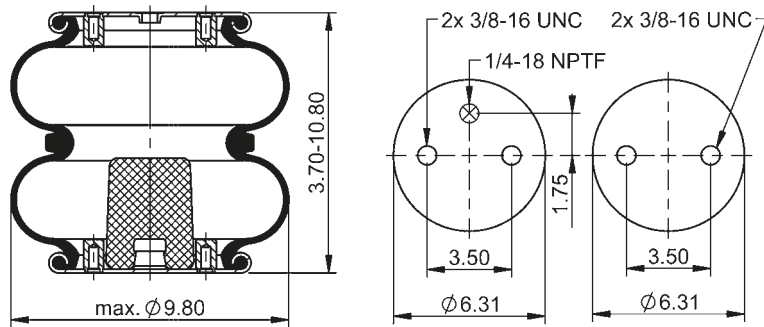

64509



7.6 lb

**Cross-reference | Cruce de Referencia**

Firestone	W01-358-6902
Goodyear	2B9-239

**Manufacturer | Fabricante**

Meritor	200042
Dayton	354-6902
Granning	4848
Hendrickson	S-2630
Loadguard	SC2010
Navistar/Fleetrite	554784C1
SAF Holland	57006902
Watson & Chalin	AS-0002
and more	

1/4-18 NPTF: max. 22 lbft  
3/8-16 UNC: max. 20 lbft

### FD 200-19 315

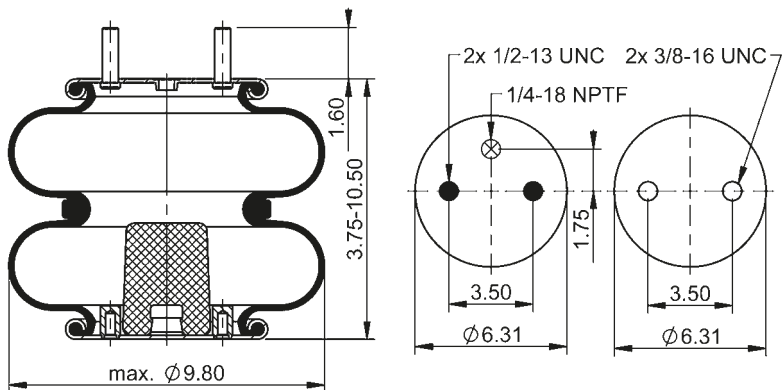

64510



7.7 lb

**Cross-reference | Cruce de Referencia**

Firestone	W01-358-6905
Goodyear	2B9-206

**Manufacturer | Fabricante**

Hendrickson	45843-1
	S-3518
	S-5270
Navistar/Fleetrite	1685175C1
SAF Holland	57006905
Silent Drive	AS-6882
Volvo	85101146
Watson & Chalin	AS-0020
and more	

1/4-18 NPTF: max. 22 lbft  
3/8-16 UNC: max. 20 lbft  
1/2-13 UNC: max. 35 lbft

### FD 200-19 319

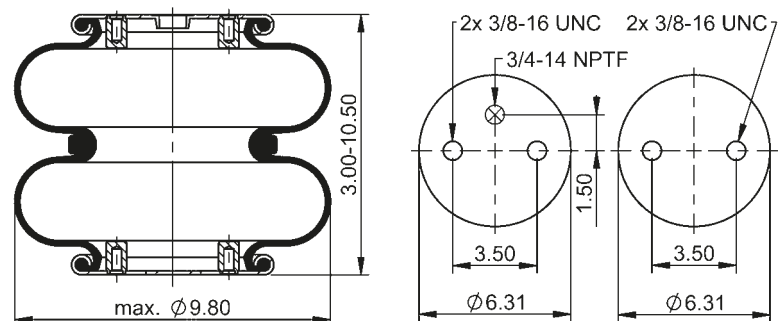

64271



6.4 lb

**Cross-reference | Cruce de Referencia**

Firestone	W01-358-6900
Goodyear	2B9-216

**Manufacturer | Fabricante**

DINA	AZ-8127-19
Prevost	63-0173
Ridewell	1003586900C
Suspension Dynamics	630173
Watson & Chalin	AS-0156-1G

3/8-16 UNC: max. 20 lbft  
3/4-14 NPTF: max. 22 lbft

### FD 200-19 320

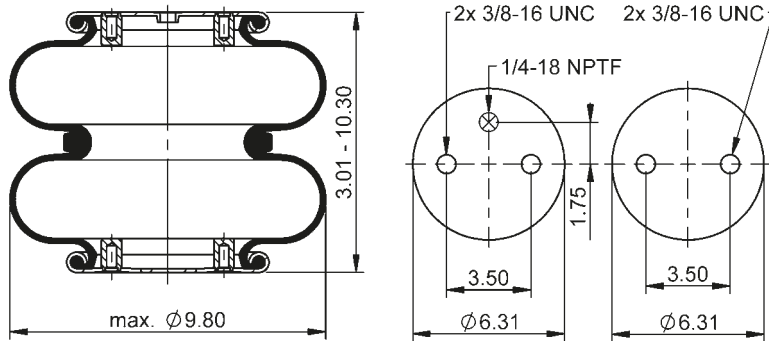

64267



**lb** 6.4 lb

**Cross-reference | Cruce de Referencia**

Firestone	W01-358-6910
Goodyear	2B9-200

**Manufacturer | Fabricante**

Granning	1371 2726
Hendrickson	5-8768 45843-3
Navistar/Fleetrite	554783C1
Prevost	63-0174
SAF Holland	57006910
Watson & Chalin	AS-0001
and more	

1/4-18 NPTF: max. 22 lb-ft  
3/8-16 UNC: max. 20 lb-ft

### FD 200-19 362

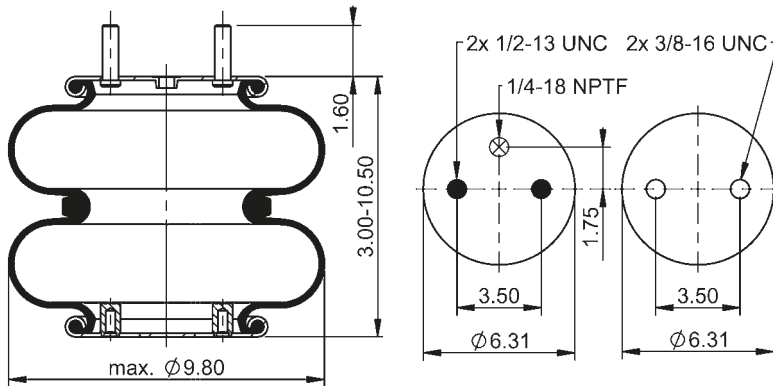

64511



**lb** 6.5 lb

**Cross-reference | Cruce de Referencia**

Firestone	W01-358-6908
Goodyear	2B9-210

**Manufacturer | Fabricante**

Loadguard	SC2766
Ridewell	1003586908C
Warren	8030120
Watson & Chalin	AS-0035

1/4-18 NPTF: max. 22 lb-ft  
3/8-16 UNC: max. 20 lb-ft  
1/2-13 UNC: max. 35 lb-ft

### FD 200-19 448

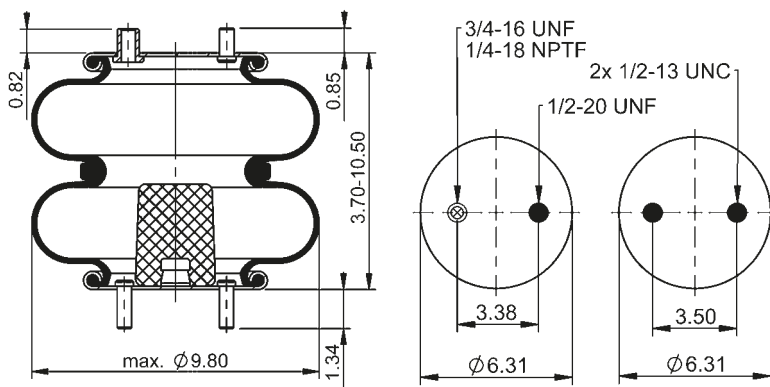

64512



**lb** 7.6 lb

**Cross-reference | Cruce de Referencia**

Firestone	W01-358-6941
Goodyear	2B9-280 2B9-265

**Manufacturer | Fabricante**

Granning	7631
Histeer	10302
Link	1103-0002
Loadguard	SC2124
SAF Holland	57006941
Suspensions, Inc.	200118

1/4-18 NPTF: max. 22 lb-ft  
1/2-20 UNF: max. 35 lb-ft  
3/4-16 UNF: max. 50 lb-ft



### FD 200-19 450

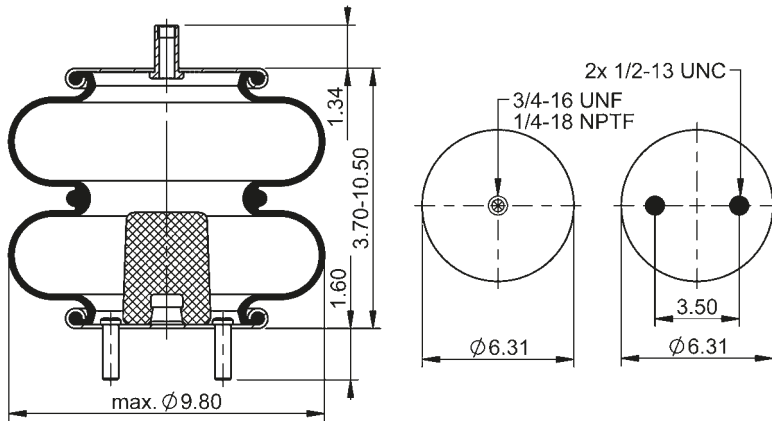

64513



**lb** 7.6 lb

**Cross-reference | Cruce de Referencia**

Firestone W01-358-6940  
Goodyear 2B9-230

**Manufacturer | Fabricante**

Histeer 10305  
Loadguard SC2035  
SC2762

1/4-18 NPTF: max. 22 lb-ft  
1/2-13 UNC: max. 35 lb-ft  
3/4-16 UNF: max. 50 lb-ft

### FD 200-19 452

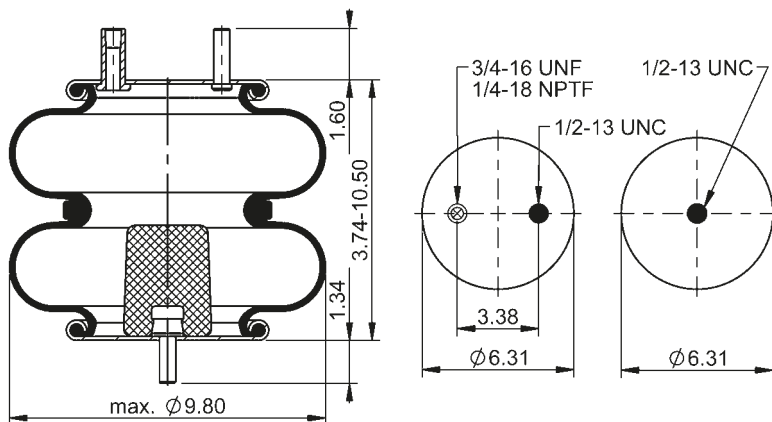

64514



**lb** 7.6 lb

**Cross-reference | Cruce de Referencia**

Firestone W01-358-6932  
Goodyear 2B9-246

**Manufacturer | Fabricante**

Loadguard SC2046  
Ridewell 1003586932C

1/4-18 NPTF: max. 22 lb-ft  
1/2-13 UNC: max. 35 lb-ft  
3/4-16 UNF: max. 50 lb-ft

### FD 200-19 499

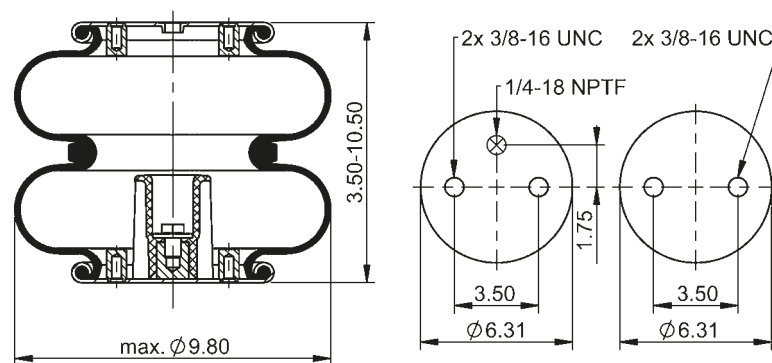

64515



**lb** 7.0 lb

**Cross-reference | Cruce de Referencia**

Firestone W01-358-6935  
W01-358-6856  
Goodyear 2B9-201

**Manufacturer | Fabricante**

Meritor 201548  
Freightliner 16-14318-000  
Granning 4848  
702932-01  
Hendrickson S-14318  
Loadguard SC2010  
Navistar/Fleetrite 554784C1  
2B9-491

and more  
 1/4-18 NPTF: max. 22 lb-ft  
3/8-16 UNC: max. 20 lb-ft

### FD 200-19 504

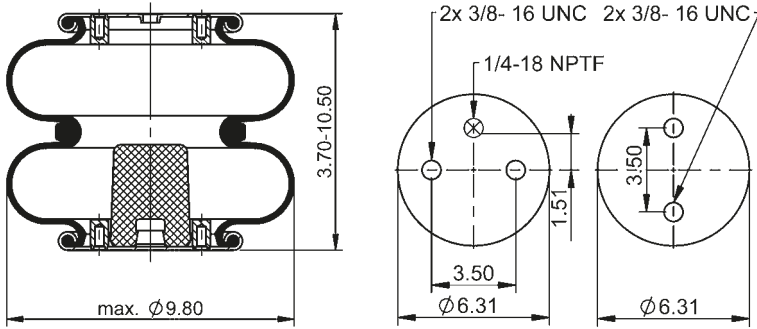

### 64516



**lb** 7.6 lb

#### Cross-reference | Cruce de Referencia

Firestone	W01-358-6926
Goodyear	2B9-288

1/4-18 NPTF: max. 22 lb-ft  
3/8-16 UNC: max. 20 lb-ft

### FD 200-19 505

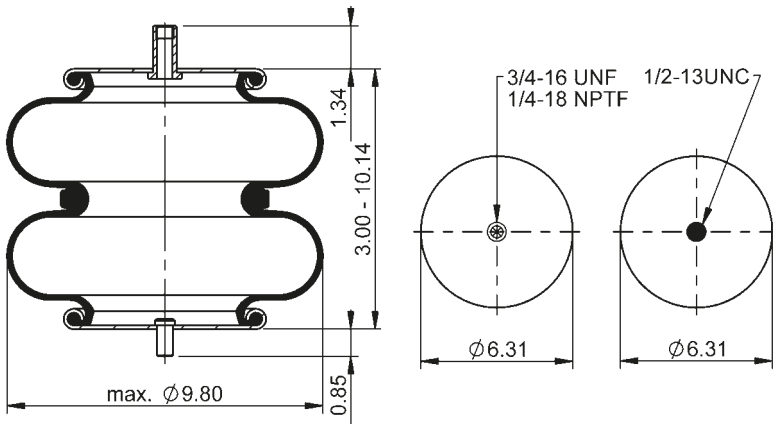

### 64517



**lb** 6.3 lb

#### Cross-reference | Cruce de Referencia

Firestone	W01-358-6897
Goodyear	2B9-229

#### Manufacturer | Fabricante

Brake & Wheel	M3528
Navistar/Fleetrite	2B9-490
Ridewell	1003586897C
Watson & Chalin	AS-0058

1/4-18 NPTF: max. 22 lb-ft  
1/2-13 UNC: max. 35 lb-ft  
3/4-16 UNF: max. 50 lb-ft

### FD 200-19 506

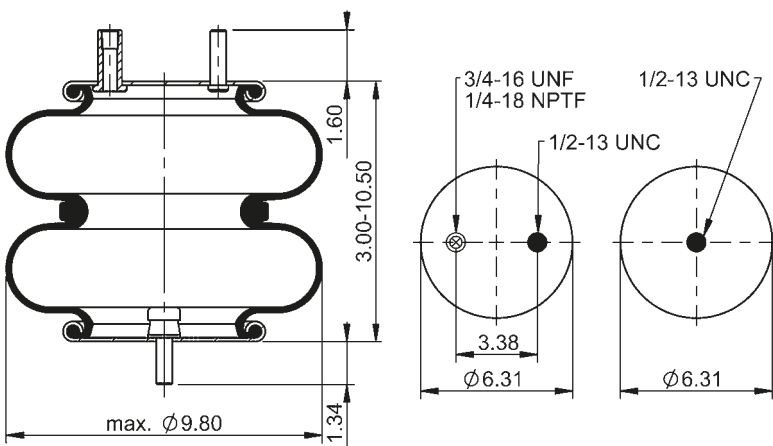

### 64518



**lb** 6.6 lb

#### Cross-reference | Cruce de Referencia

Firestone	W01-358-6949
-----------	--------------

#### Manufacturer | Fabricante

Meritor	200183
Load Air	P10-872-A
Sauer	P10-872A

1/4-18 NPTF: max. 22 lb-ft  
1/2-13 UNC: max. 35 lb-ft  
3/4-16 UNF: max. 50 lb-ft

### FD 200-19 510

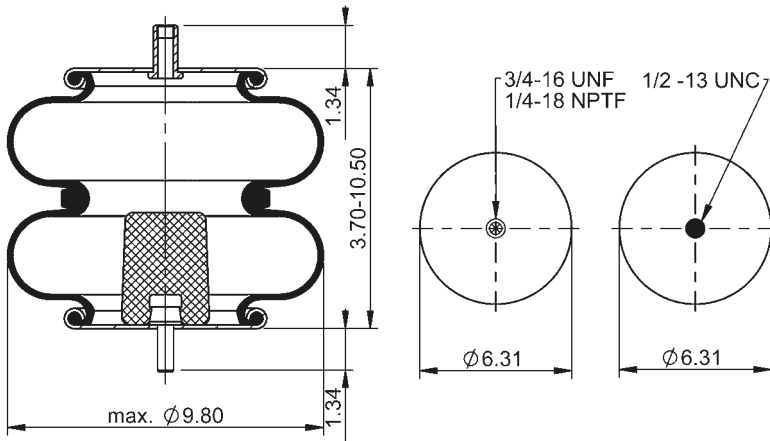

64519



**lb** 7.5 lb

**Cross-reference | Cruce de Referencia**

Firestone	W01-358-7788
Goodyear	2B9-245

**Manufacturer | Fabricante**

Watson & Chalin	AS-0088
-----------------	---------

- 1/4-18 NPTF: max. 22 lb-ft
- 1/2-13 UNC: max. 35 lb-ft
- 3/4-16 UNF: max. 50 lb-ft

### FD 200-19 539

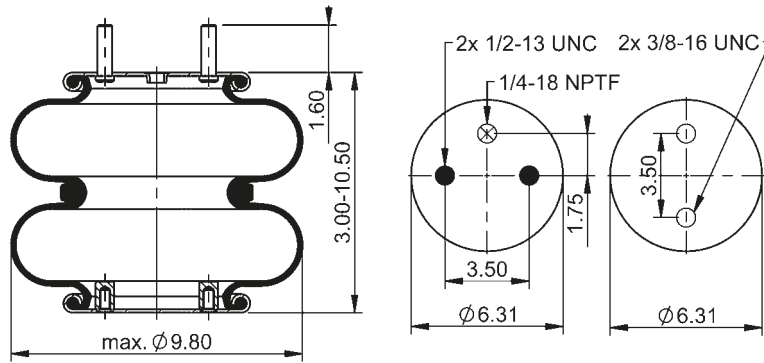

64520



**lb** 6.6 lb

**Cross-reference | Cruce de Referencia**

Firestone	W01-358-6890
Goodyear	2B9-606

**Manufacturer | Fabricante**

SAF Holland	90557228
-------------	----------

- 1/4-18 NPTF: max. 22 lb-ft
- 3/8-16 UNC: max. 20 lb-ft
- 1/2-13 UNC: max. 35 lb-ft

### FD 200-19 712

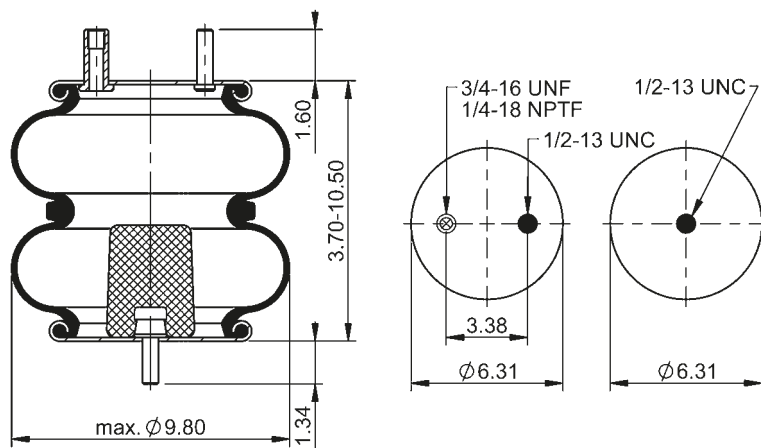

64685



**lb** 7.6 lb

**Cross-reference | Cruce de Referencia**

Firestone	W01-358-7686
-----------	--------------

**Manufacturer | Fabricante**

Rowe Truck	0035ASC1600
	0035ASC2500

- 1/4-18 NPTF: max. 18 lb-ft
- 1/2-13 UNC: max. 35 lb-ft
- 3/4-16 UNF: max. 50 lb-ft

### FD 200-19 713

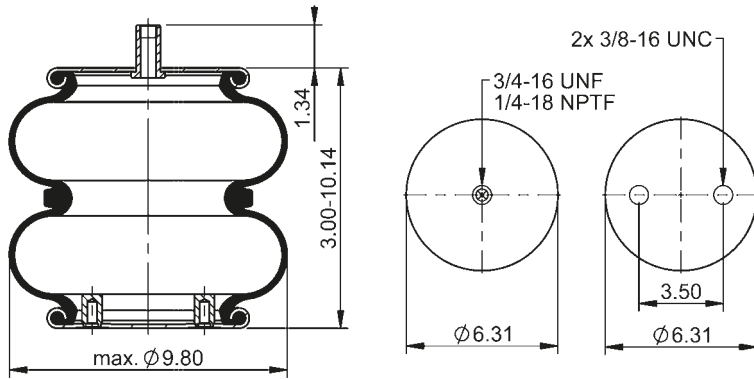

67705



**lb** 6.4 lb

**Cross-reference | Cruce de Referencia**

Firestone	W01-358-7795
Goodyear	2B10-226

**Manufacturer | Fabricante**

Hendrickson	3317
	B-14486
Watson & Chalin	AS-0146-1G

1/4-18 NPTF: max. 22 lb-ft

3/8-16 UNC: max. 20 lb-ft

3/4-16 UNF: max. 50 lb-ft

### FD 200-19 724

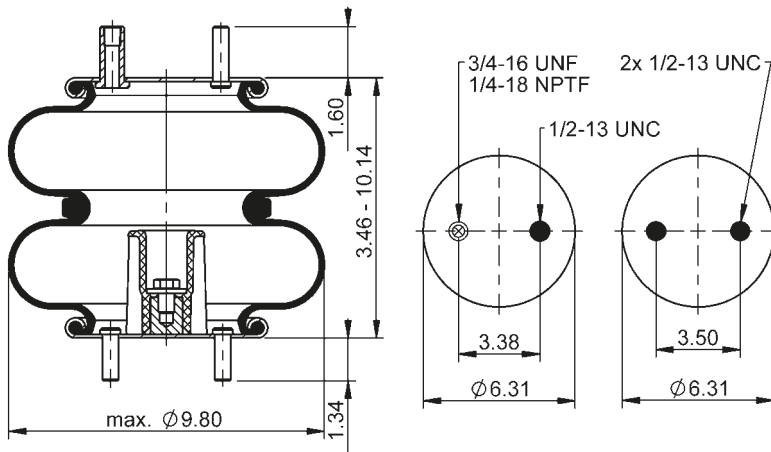

64712



**lb** 7.2 lb

**Cross-reference | Cruce de Referencia**

Firestone	W01-358-6884
-----------	--------------

**Manufacturer | Fabricante**

Link	1103-0019
------	-----------

1/4-18 NPTF: max. 22 lb-ft

1/2-13 UNC: max. 35 lb-ft

3/4-16 UNF: max. 50 lb-ft

### FD 200-19 761

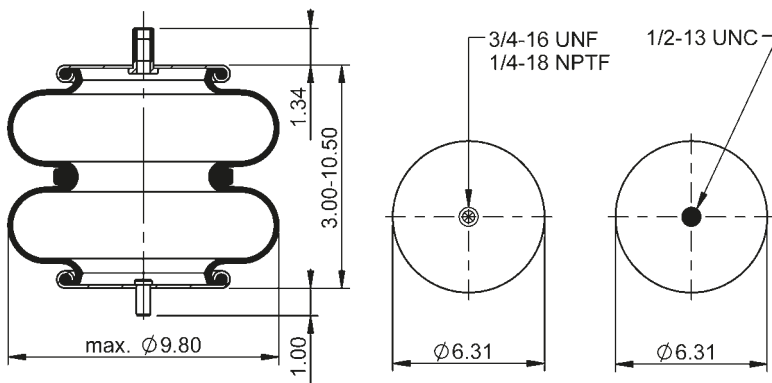

75977



**lb** 6.4 lb

**Manufacturer | Fabricante**

Watson & Chalin	AS-0058C
-----------------	----------

1/4-18 NPTF: max. 22 lb-ft

1/2-13 UNC: max. 35 lb-ft

3/4-16 UNF: max. 50 lb-ft

### FD 200-19 836

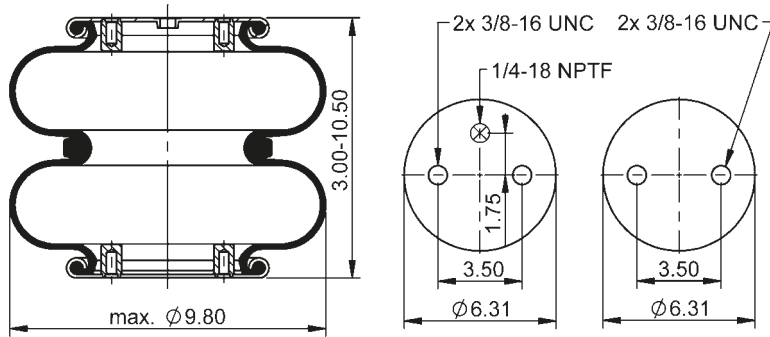

70121



6.4 lb

**Manufacturer | Fabricante**  
Hendrickson S-10214

1/4-18 NPTF: max. 18 lb-ft  
3/8-16 UNC: max. 18 lb-ft

### FD 200-19 894

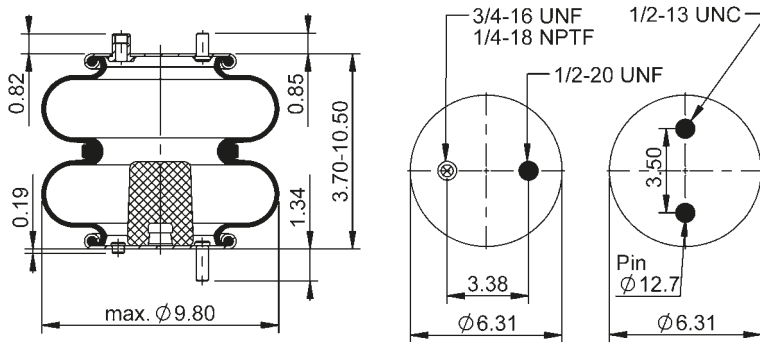

70658



7.0 lb

**Cross-reference | Cruce de Referencia**  
Goodyear 2B9-614

1/4-18 NPTF: max. 22 lb-ft  
1/2-13 UNC: max. 35 lb-ft  
3/4-16 UNF: max. 50 lb-ft

### FD 200-19 895

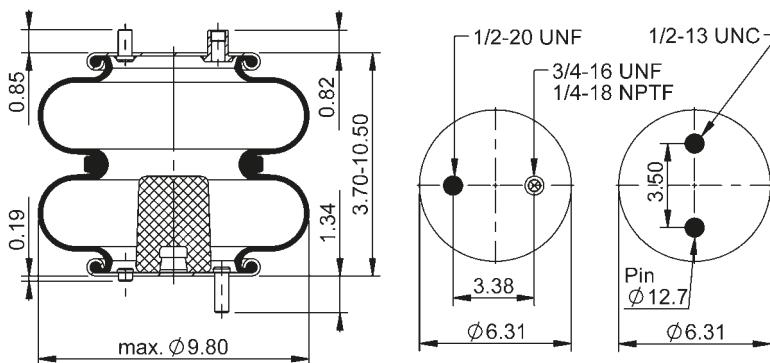

70659



3.7 lb

**Cross-reference | Cruce de Referencia**  
Goodyear 2B9-611

1/4-18 NPTF: max. 22 lb-ft  
1/2-13 UNC: max. 35 lb-ft  
3/4-16 UNF: max. 50 lb-ft

### FD 200-19 1148

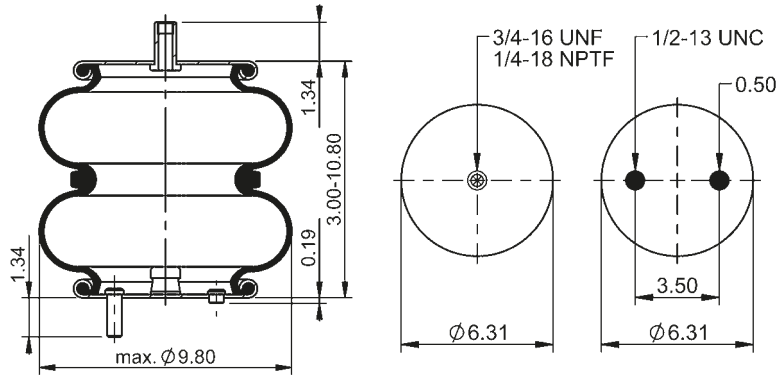

77120



**lb** 6.5 lb

**Cross-reference | Cruce de Referencia**  
Goodyear 2B9-296

**Manufacturer | Fabricante**  
Ridewell 1002B09296G

**1/4-18 NPTF:** max. 22 lb-ft  
**1/2-13 UNC:** max. 35 lb-ft  
**3/4-16 UNF:** max. 50 lb-ft

### FD 200-19A 730

**new**

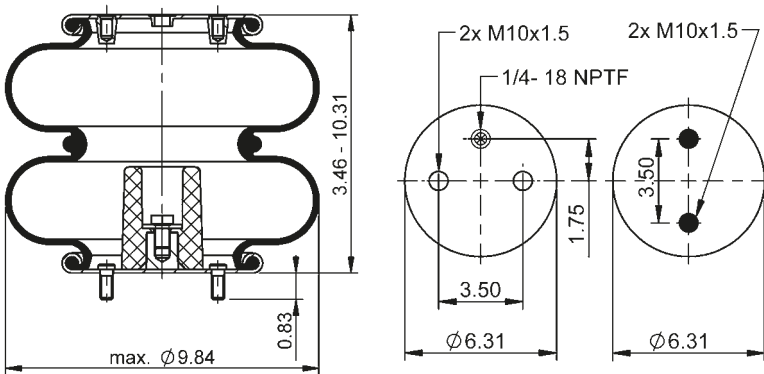

70120



**lb** 7.3 lb

**Manufacturer | Fabricante**  
Hendrickson 3318

**1/4-18 NPTF:** max. 22 lb-ft  
**M10:** max. 18 lb-ft

### FD 200-20 785

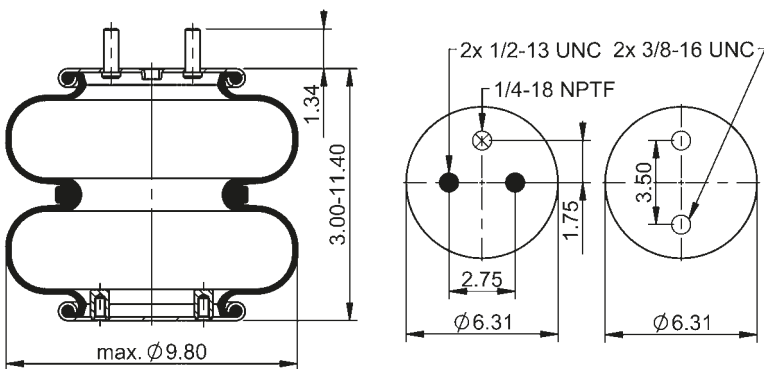

67706



**lb** 6.6 lb

**Manufacturer | Fabricante**  
SAF Holland 90557366

**1/4-18 NPTF:** max. 22 lb-ft  
**3/8-16 UNC:** max. 18 lb-ft  
**1/2-13 UNC:** max. 35 lb-ft

### FD 200-22 524

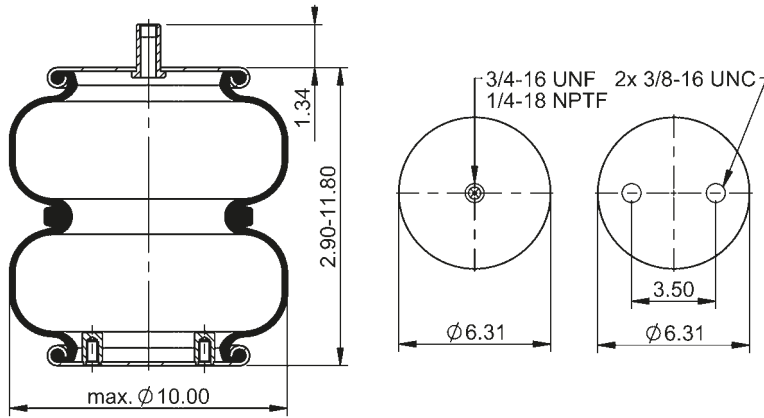

64602



**lb** 6.6 lb

**Manufacturer | Fabricante**  
Hendrickson 2878

**1/4-18 NPTF:** max. 22 lb-ft  
**3/8-16 UNC:** max. 20 lb-ft  
**3/4-16 UNF:** max. 50 lb-ft

### FD 200-22 529

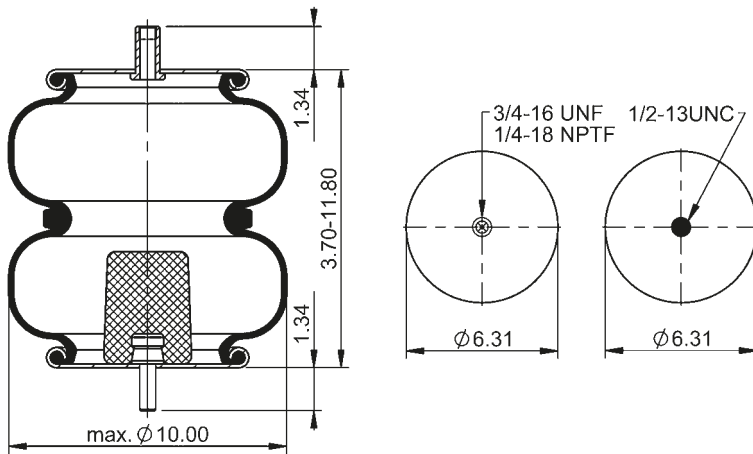

64558



**lb** 7.7 lb

**Cross-reference | Cruce de Referencia**

Firestone W01-358-6883  
Goodyear 2B9-283

**Manufacturer | Fabricante**  
Watson & Chalin AS-0092

**1/4-18 NPTF:** max. 22 lb-ft  
**1/2-13 UNC:** max. 35 lb-ft  
**3/4-16 UNF:** max. 50 lb-ft

### FD 200-22 706

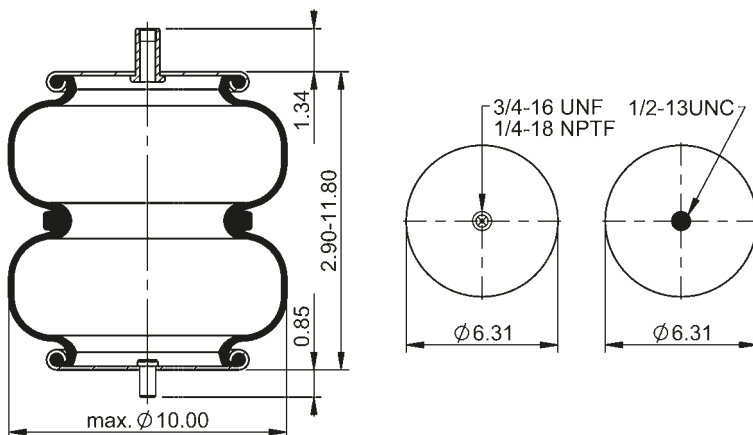

64665



**lb** 6.5 lb

**Cross-reference | Cruce de Referencia**

Firestone W01-358-6886  
Goodyear 2B9-229

**Manufacturer | Fabricante**  
Reyco 701784-01  
Watson & Chalin AS-0058-1F

**1/4-18 NPTF:** max. 22 lb-ft  
**1/2-13 UNC:** max. 35 lb-ft  
**3/4-16 UNF:** max. 50 lb-ft

### FD 200-22 765

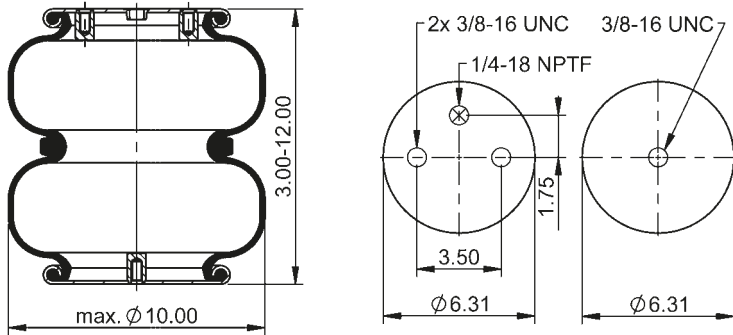

66662



6.6 lb

**Cross-reference | Cruce de Referencia**  
Firestone W01-358-6703

**Manufacturer | Fabricante**  
Lippert 156727

1/4-18 NPTF: max. 22 lb-ft  
3/8-16 UNC: max. 20 lb-ft

### FD 200-22 A 908

**new**

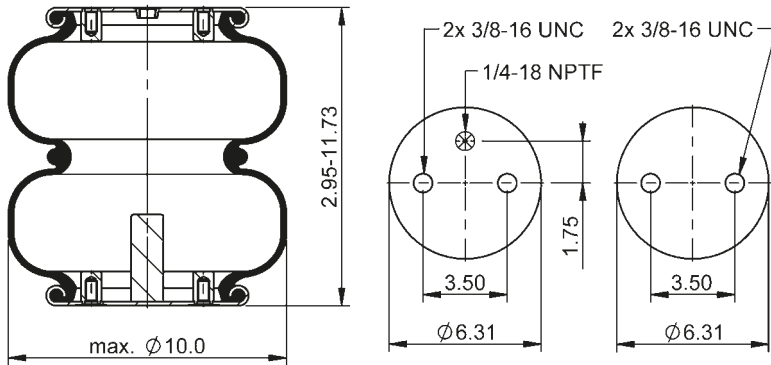

600929



7.1 lb

**Manufacturer | Fabricante**  
Hendrickson 10214

1/4-18 NPTF: max. 22 lb-ft  
3/8-16 UNC: max. 18 lb-ft

### FD 200-22A 1062

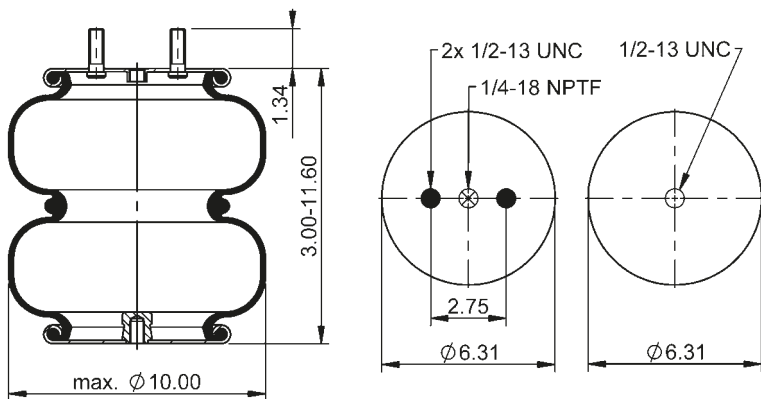

78246



6.6 lb

**Cross-reference | Cruce de Referencia**  
Firestone W01-358-7891

**Manufacturer | Fabricante**  
Hendrickson 5360

1/8-27 NPTF: max. 22 lb-ft  
1/2-13 UNC: max. 35 lb-ft



### FD 200-23A 709

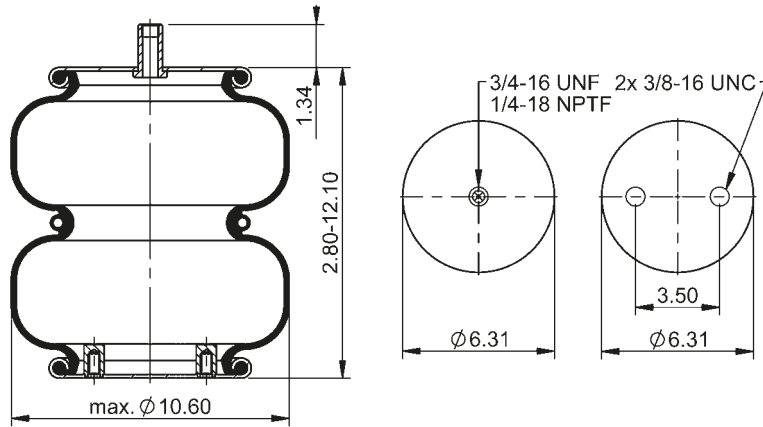

64683



**lb** 6.6 lb

**Cross-reference | Cruce de Referencia**

Firestone	W01-358-7897
Goodyear	2B9-495

**Manufacturer | Fabricante**

Hendrickson	S-23114
-------------	---------

1/4-18 NPTF: max. 22 lb-ft  
 3/8-16 UNC: max. 20 lb-ft  
 3/4-16 UNF: max. 50 lb-ft

### FD 200-25 426

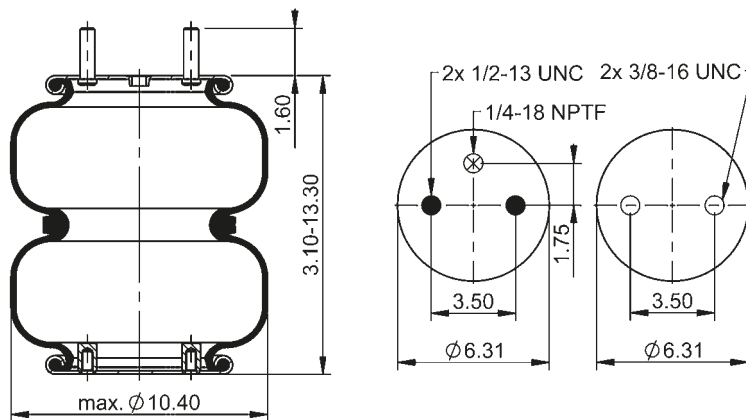

64549



**lb** 7.0 lb

**Cross-reference | Cruce de Referencia**

Firestone	W01-358-6943
Goodyear	2B9-250

**Manufacturer | Fabricante**

Granning	6352
Loadguard	SC2122
SAF Holland	90557237
Spring Valley	AS-4426
Suspensions, Inc.	200835
Watson & Chalin	AS-0041

1/4-18 NPTF: max. 22 lb-ft  
 3/8-16 UNC: max. 20 lb-ft  
 1/2-13 UNC: max. 35 lb-ft

### FD 200-25 427

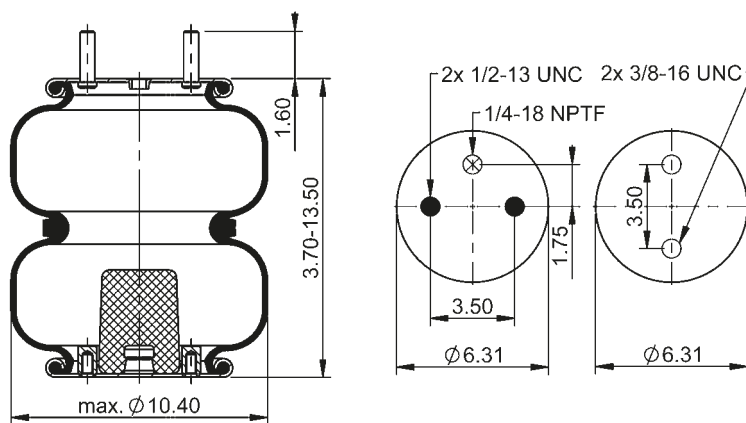

64550



**lb** 8.2 lb

**Cross-reference | Cruce de Referencia**

Firestone	W01-358-6945
Goodyear	2B9-253

**Manufacturer | Fabricante**

Loadguard	SC2125
Ridewell	1003586945C
Watson & Chalin	AS-0119-F AS-0145-1G

1/4-18 NPTF: max. 22 lb-ft  
 3/8-16 UNC: max. 20 lb-ft  
 1/2-13 UNC: max. 35 lb-ft

### FD 200-25 428

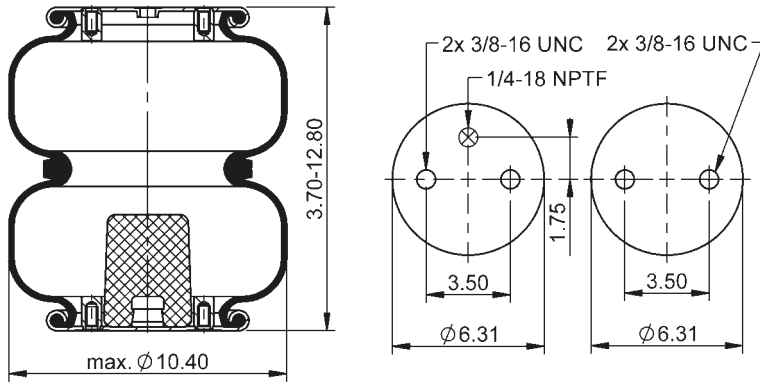

64551



8.1 lb

**Cross-reference | Cruce de Referencia**

Firestone	W01-358-6947
Goodyear	2B9-255

**Manufacturer | Fabricante**

Dayton	354-6947
Hendrickson	S-8701
Loadguard	SC2127
Ridewell	1003586947C
SAF Holland	57006947

1/4-18 NPTF: max. 22 lb-ft  
3/8-16 UNC: max. 20 lb-ft

### FD 200-25 429

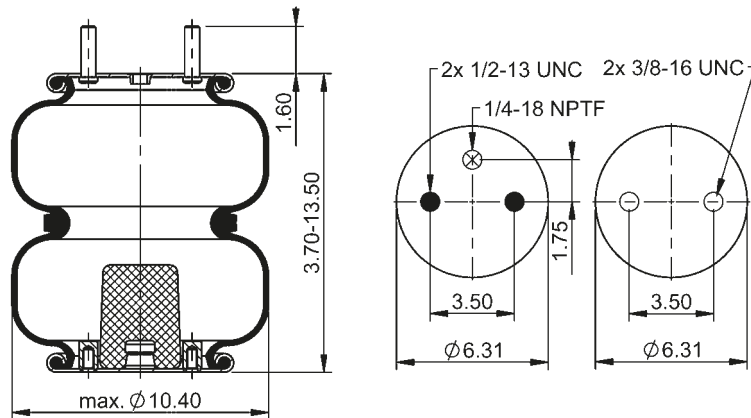

64552



8.2 lb

**Cross-reference | Cruce de Referencia**

Firestone	W01-358-6948
Goodyear	2B9-251

**Manufacturer | Fabricante**

Cush	C-0080
Loadguard	SC2123
Ridewell	1003586948C
Silent Drive	AS-6948
Spring Valley	AS-4429
Watson & Chalin	AS-0122-G

1/4-18 NPTF: max. 22 lb-ft  
3/8-16 UNC: max. 20 lb-ft  
1/2-13 UNC: max. 35 lb-ft

### FD 200-25 453

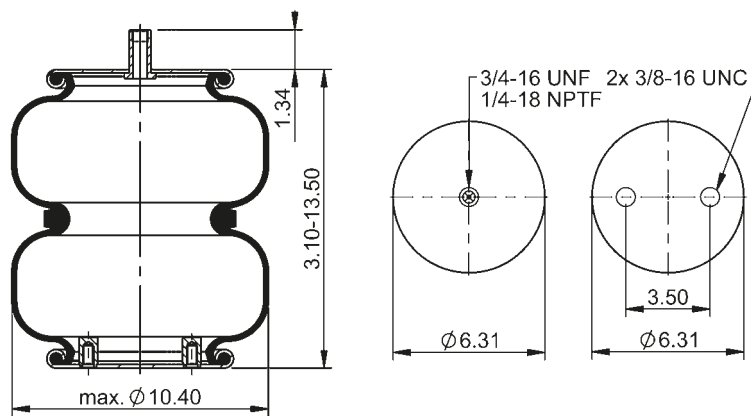

64553



6.9 lb

**Cross-reference | Cruce de Referencia**

Firestone	W01-358-6927
Goodyear	2B9-218

**Manufacturer | Fabricante**

Loadguard	SC2072
Navistar/Fleetrite	1685176C1
Reyco	12906-02
	12906-01
SAF Holland	57006927
Taurus	AS218-6927

1/4-18 NPTF: max. 22 lb-ft  
3/8-16 UNC: max. 20 lb-ft  
3/4-16 UNF: max. 50 lb-ft

### FD 200-25 454

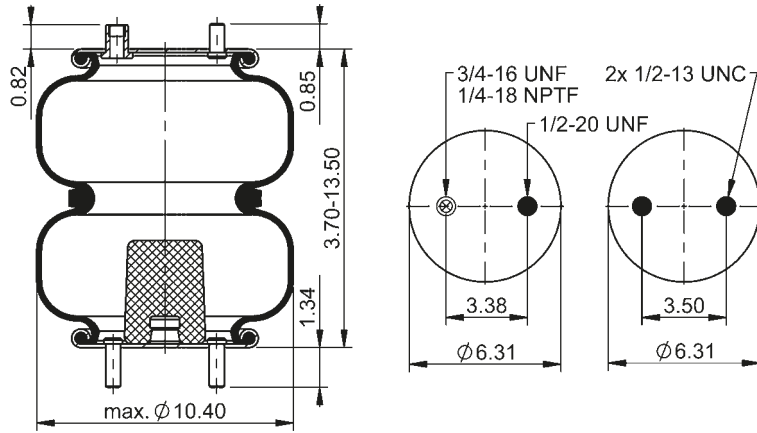

64554



8.2 lb

**Cross-reference | Cruce de Referencia**

Firestone	W01-358-6944
Goodyear	2B9-252
	2B9-266

**Manufacturer | Fabricante**

Meritor	200118
Granning	7639
	6390
Histeer	10307
Loadguard	SC2124
Suspensions, Inc.	200118
Watson & Chalin	AS-0115-G

- 1/4-18 NPTF: max. 22 lbft
- 1/2-20 UNF: max. 35 lbft
- 3/4-16 UNF: max. 50 lbft

### FD 200-25 463

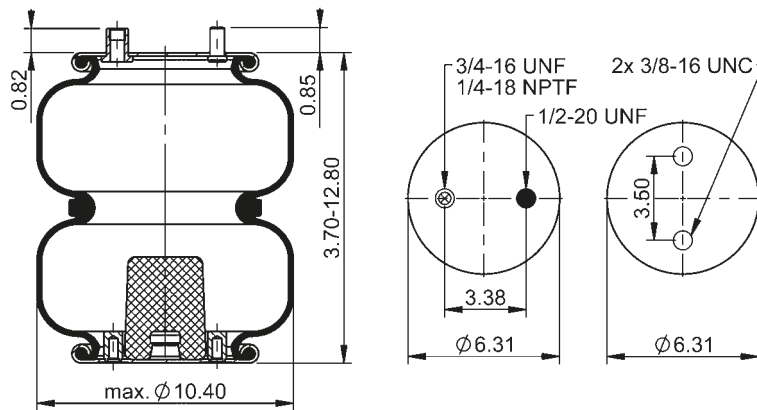

64555



8.2 lb

**Cross-reference | Cruce de Referencia**

Firestone	W01-358-6946
Goodyear	2B9-254

**Manufacturer | Fabricante**

Meritor	200180
Loadguard	SC2126
Ridewell	1003586946C
Suspensions, Inc.	200180

- 1/4-18 NPTF: max. 22 lbft
- 3/8-16 UNC: max. 20 lbft
- 1/2-20 UNF: max. 35 lbft

### FD 200-25 507

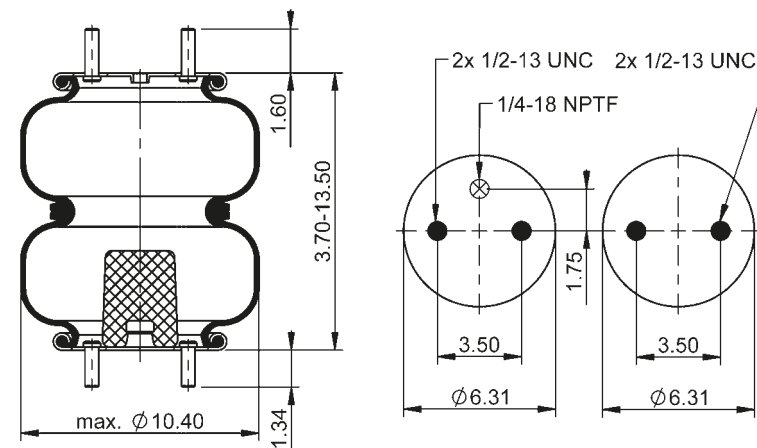

64556



8.2 lb

**Cross-reference | Cruce de Referencia**

Firestone	W01-358-6960
-----------	--------------

**Manufacturer | Fabricante**

Granning	7025
----------	------

- 1/4-18 NPTF: max. 22 lbft
- 1/2-13 UNC: max. 35 lbft

### FD 200-25 511

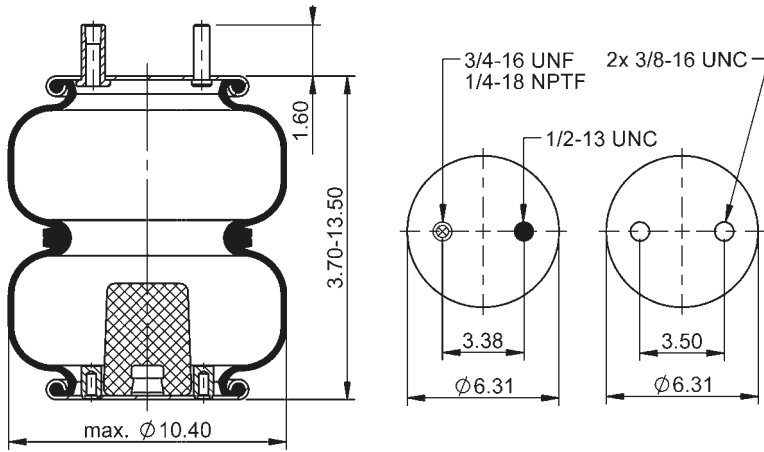

64557



**lb** 8.2 lb

**Cross-reference | Cruce de Referencia**

Firestone W01-358-6962  
Goodyear 2B9-607

**Manufacturer | Fabricante**

Hendrickson S-21323

- 1/4-18 NPTF: max. 22 lb-ft
- 3/8-16 UNC: max. 20 lb-ft
- 3/4-16 UNF: max. 50 lb-ft

### FD 200-25 717

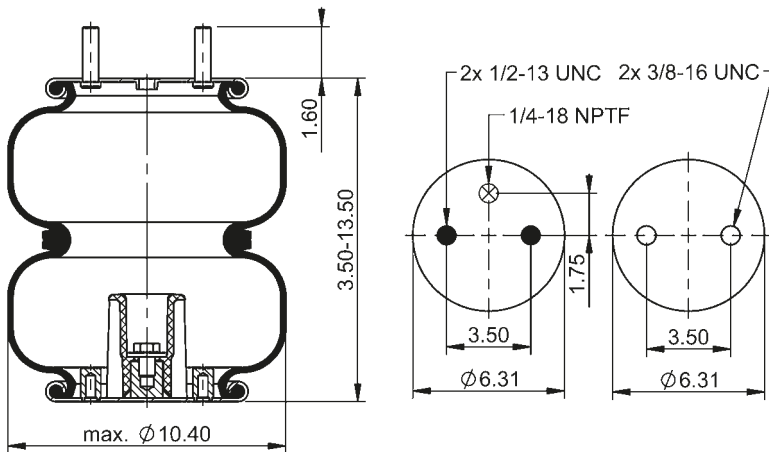

64702



**lb** 7.9 lb

**Cross-reference | Cruce de Referencia**

Firestone W01-358-6393

**Manufacturer | Fabricante**

Monaco Coach 0180 7468

- 1/4-18 NPTF: max. 22 lb-ft
- 3/8-16 UNC: max. 20 lb-ft
- 1/2-13 UNC: max. 35 lb-ft

### FD 200-25 721

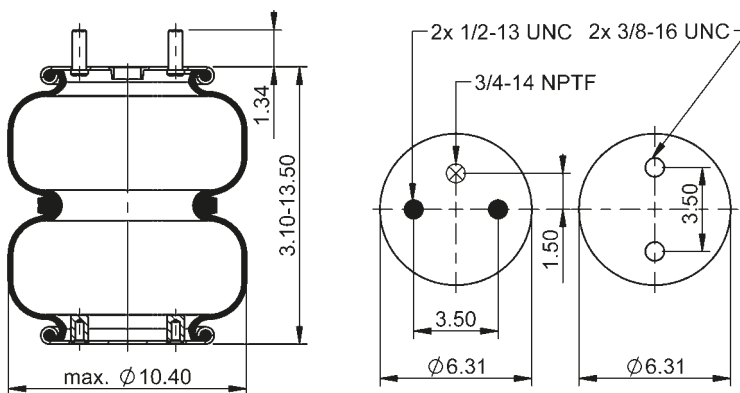

64622



**lb** 7.0 lb

**Cross-reference | Cruce de Referencia**

Firestone W01-358-6817  
Goodyear 2B9-270

**Manufacturer | Fabricante**

Watson & Chalin AS-0111-G

- 3/8-16 UNC: max. 20 lb-ft
- 1/2-13 UNC: max. 35 lb-ft
- 3/4-14 NPTF: max. 22 lb-ft

### FD 200-25 797

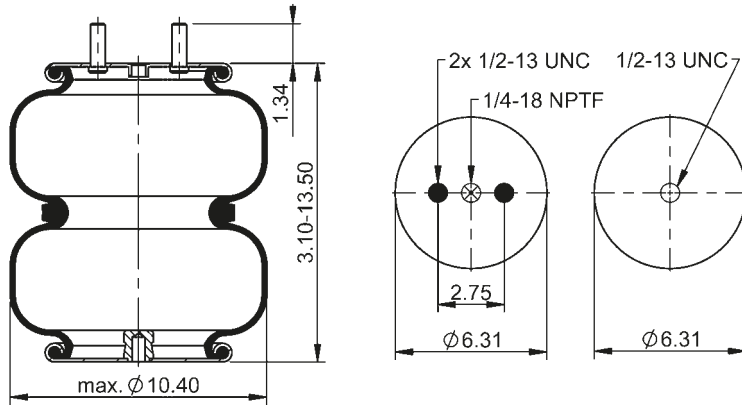

67905



**lb** 6.8 lb

**Manufacturer | Fabricante**  
Hendrickson 9189

**1/4-18 NPTF:** max. 22 lbft  
**1/2-13 UNC:** max. 35 lbft

### FD 200-25 1008

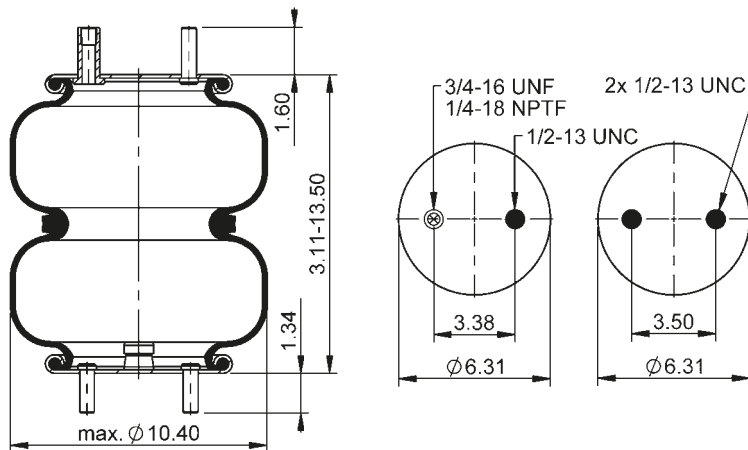

75184



**lb** 7.1 lb

**Cross-reference | Cruce de Referencia**  
Firestone W01-358-6392

**Manufacturer | Fabricante**  
Meritor 2258G1489

**1/4-18 NPTF:** max. 22 lbft  
**1/2-13 UNC:** max. 35 lbft  
**3/4-16 UNF:** max. 50 lbft

### FD 330-22 313

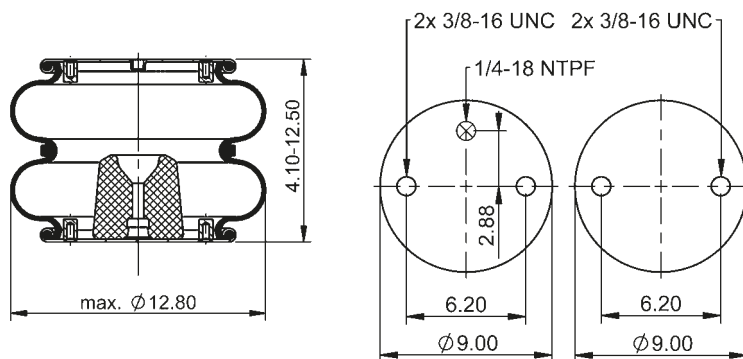

64270



**lb** 14.5 lb

**Cross-reference | Cruce de Referencia**  
Firestone W01-358-7400  
Goodyear 2B12-309

**Manufacturer | Fabricante**  
Freightliner 16-10796-000  
Granning 2726  
Hendrickson S-1013  
Navistar/Fleetrite 554788C1  
SAF Holland 90557016  
Scania 670199  
Volvo 3130488  
Watson & Chalin AS-0003  
and more

**1/4-18 NPTF:** max. 22 lbft  
**3/8-16 UNC:** max. 20 lbft

### FD 330-22 318

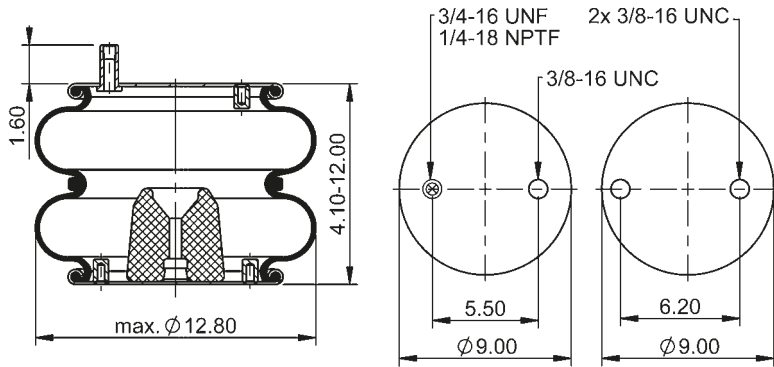

64488



**lb** 14.5 lb

**Cross-reference | Cruce de Referencia**

Firestone	W01-358-7403
Goodyear	2B12-307

**Manufacturer | Fabricante**

Meritor	200448
Granning	2725
Hendrickson	S-1159
	S-2883
	B-12514-001
SAF Holland	57007403
Volvo	352035001
Watson & Chalin	AS-0007
and more	

1/4-18 NPTF: max. 22 lbft  
3/8-16 UNC: max. 20 lbft

### FD 330-22 327

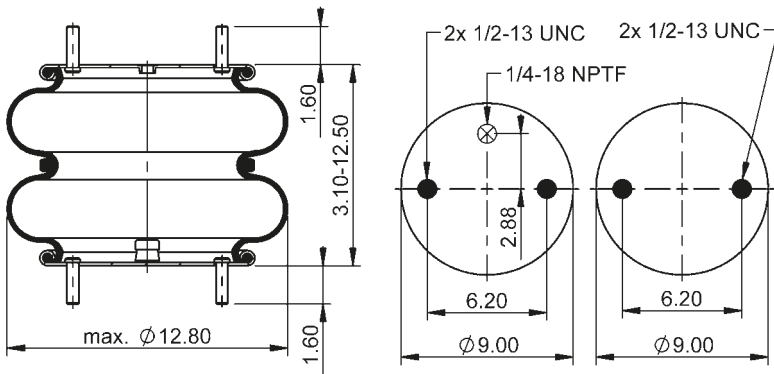

64283



**lb** 13.1 lb

**Cross-reference | Cruce de Referencia**

Firestone	W01-358-7424
Goodyear	2B12-300

**Manufacturer | Fabricante**

Granning	6421
Hendrickson	S-13043
Loadguard	SC2024
Navistar/Fleetrite	554785C1
SAF Holland	90557014
Sauer	P10-755
Volvo	3130504
Watson & Chalin	AS-0009
and more	

1/4-18 NPTF: max. 22 lbft  
1/2-13 UNC: max. 35 lbft

### FD 330-22 331

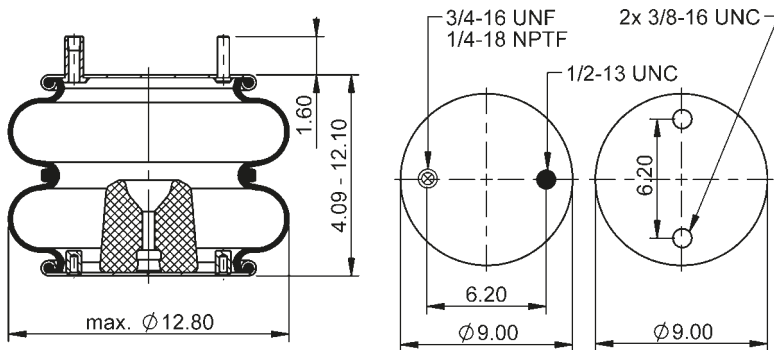

64268



**lb** 14.5 lb

**Cross-reference | Cruce de Referencia**

Firestone	W01-358-7410
Goodyear	2B12-406

**Manufacturer | Fabricante**

Freightliner	16-11378-000
Hendrickson	S-10170
	S-13036
Navistar/Fleetrite	554792C1
Ridewell	1003587410C
SAF Holland	57007410
Volvo	85101158
Watson & Chalin	AS-0136
and more	

1/4-18 NPTF: max. 22 lbft  
3/8-16 UNC: max. 20 lbft  
3/4-16 UNF: max. 50 lbft

### FD 330-22 334

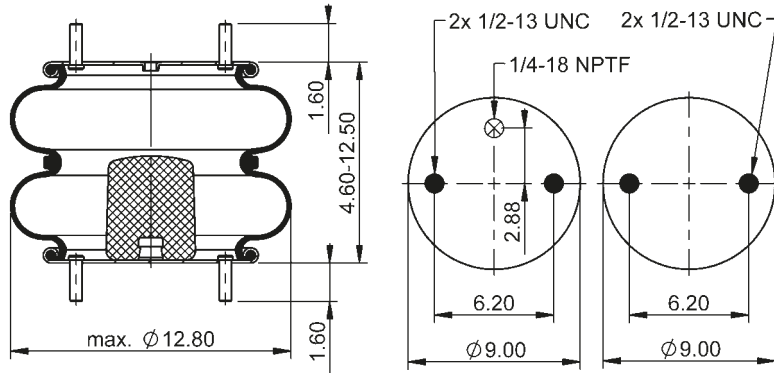

64489



14.5 lb

**Cross-reference | Cruce de Referencia**

Firestone	W01-358-7437
Goodyear	2B12-320

**Manufacturer | Fabricante**

Dayton	354-7437
GMC	711954
Hendrickson	S-13037
Loadguard	SC2025
Navistar/Fleetrite	554789C1
Ridewell	1003587437C
SAF Holland	90557015
Taurus	AS214-7437
and more	

1/4-18 NPTF: max. 22 lb-ft  
1/2-13 UNC: max. 35 lb-ft

### FD 330-22 337

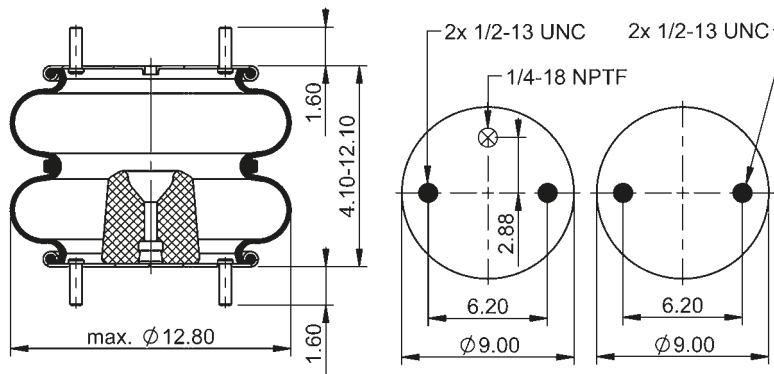

64490



14.5 lb

**Cross-reference | Cruce de Referencia**

Firestone	W01-358-7401
-----------	--------------

**Manufacturer | Fabricante**

Chevrolet	2076095
	711954
Navistar/Fleetrite	554789C1
SAF Holland	57007401
Volvo	2076095
Watson & Chalin	AS-0014

1/4-18 NPTF: max. 22 lb-ft  
1/2-13 UNC: max. 35 lb-ft

### FD 330-22 343

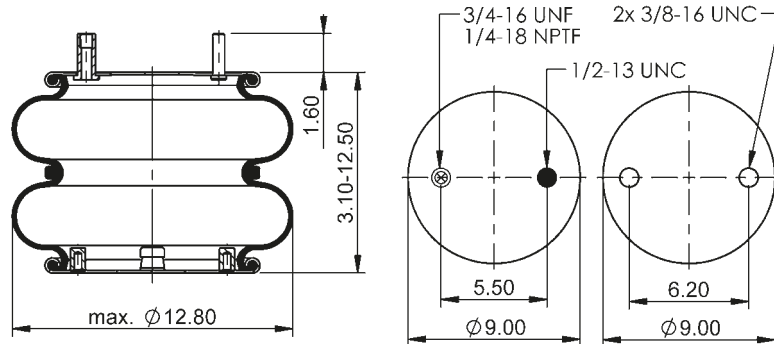

64491



13.1 lb

**Cross-reference | Cruce de Referencia**

Firestone	W01-358-7429
Goodyear	2B12-427

**Manufacturer | Fabricante**

Dayton	354-7429
Hendrickson	S-13052
Kwik Loc/Todco	CP-5223
Loadguard	SC2077
Navistar/Fleetrite	1685181C1
Ridewell	1003587429C
SAF Holland	57007429
Taurus	AS214-7429

1/4-18 NPTF: max. 22 lb-ft  
3/8-16 UNC: max. 20 lb-ft  
3/4-16 UNF: max. 50 lb-ft

### FD 330-22 346

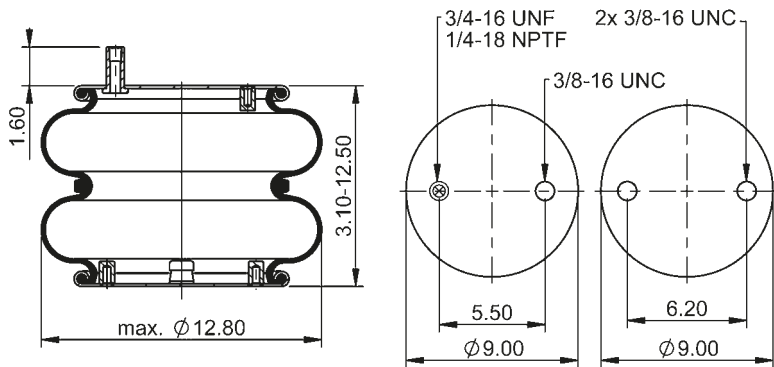

64492



**lb** 13.1 lb

**Cross-reference | Cruce de Referencia**

Firestone	W01-358-7404
Goodyear	2B12-410

**Manufacturer | Fabricante**

Dayton	354-7404
Hendrickson	S-5468
	S-1345
Loadguard	SC2022
Navistar/Fleetrite	554793C1
Ridewell	1003587404C
SAF Holland	57007404
Taurus	AS214-7404

1/4-18 NPTF: max. 22 lb-ft  
 3/8-16 UNC: max. 20 lb-ft  
 3/4-16 UNF: max. 50 lb-ft

### FD 330-22 363

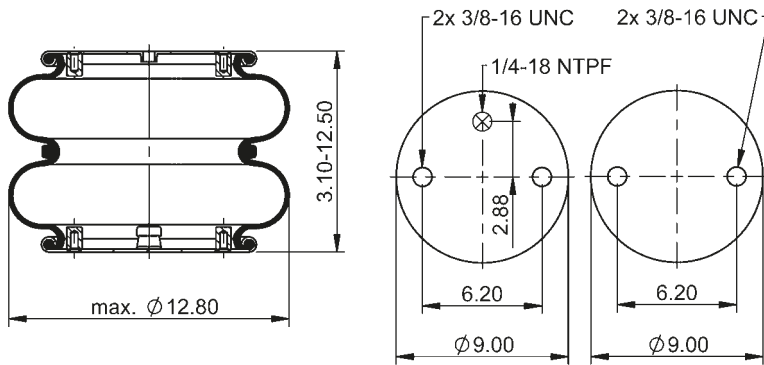

64493



**lb** 13.1 lb

**Cross-reference | Cruce de Referencia**

Firestone	W01-358-7180
Goodyear	2B12-425

**Manufacturer | Fabricante**

EZ Ride	8030190
Loadguard	SC2075
Navistar/Fleetrite	1685179C1
Peerless	0550-00001
Ridewell	1003587180C
SAF Holland	57007180
Taurus	AS214-7180

1/4-18 NPTF: max. 22 lb-ft  
 3/8-16 UNC: max. 20 lb-ft

### FD 330-22 364

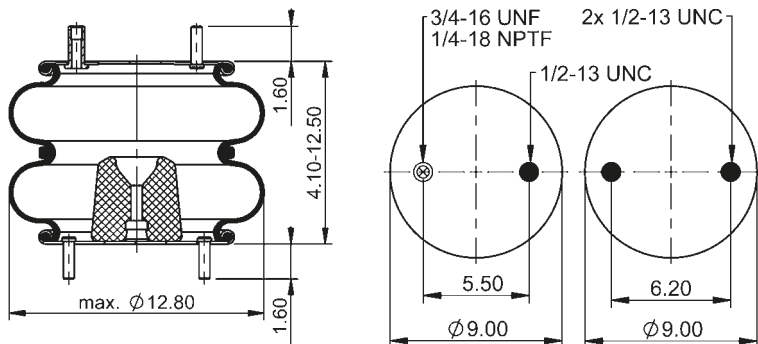

64494



**lb** 14.5 lb

**Cross-reference | Cruce de Referencia**

Firestone	W01-358-7405
Goodyear	2B12-313

**Manufacturer | Fabricante**

Meritor	200981
Hutchens	10384-01
Loadguard	SC2073
Mack	57QK1113
	227QS32
Navistar/Fleetrite	1685177C1
SAF Holland	57007405
Taurus	AS214-7405
and more	

1/4-18 NPTF: max. 22 lb-ft  
 1/2-13 UNC: max. 35 lb-ft  
 3/4-16 UNF: max. 50 lb-ft



### FD 330-22 365

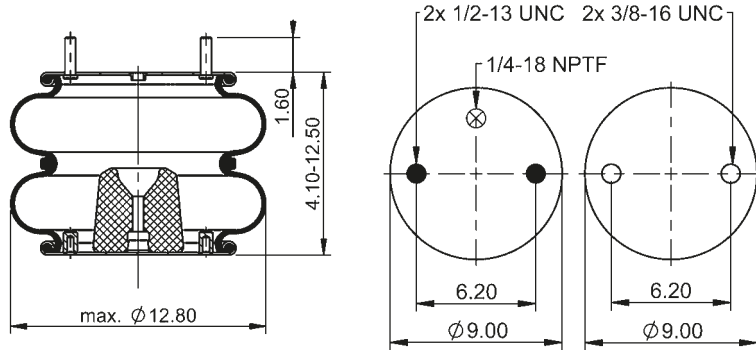

64495



14.5 lb

**Cross-reference | Cruce de Referencia**

Firestone	W01-358-7406
Goodyear	2B12-426

**Manufacturer | Fabricante**

Dayton	354-7406
Loadguard	SC2076
Navistar/Fleetrite	1685180C1
Ridewell	1003587406C
SAF Holland	57007406
Sauer	P10-784
Taurus	AS214-7406

1/4-18 NPTF: max. 22 lb-ft  
1/2-13 UNC: max. 35 lb-ft

### FD 330-22 366

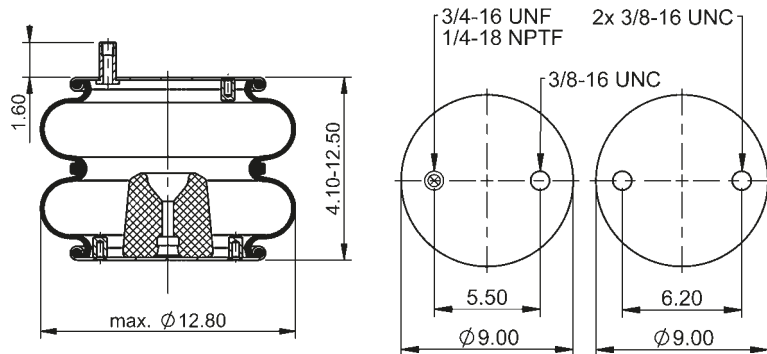

64496



14.5 lb

**Cross-reference | Cruce de Referencia**

Firestone	W01-358-7408
-----------	--------------

**Manufacturer | Fabricante**

Porcupine	7818
-----------	------

1/4-18 NPTF: max. 22 lb-ft  
3/8-16 UNC: max. 20 lb-ft  
3/4-16 UNF: max. 50 lb-ft

### FD 330-22 367

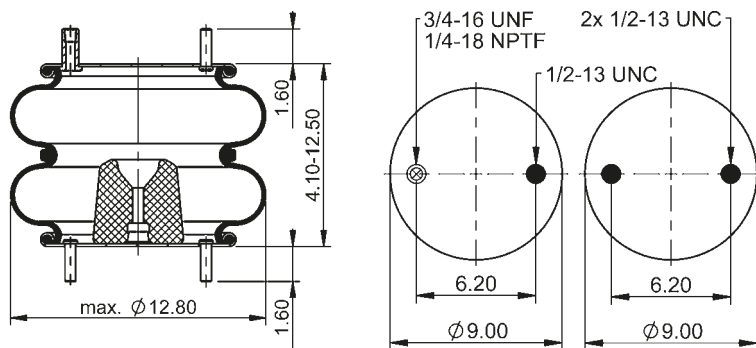

64497



14.5 lb

**Cross-reference | Cruce de Referencia**

Firestone	W01-358-7409
Goodyear	2B12-319

**Manufacturer | Fabricante**

Dayton	354-7409
Loadguard	SC2074
Navistar/Fleetrite	1685178C1
SAF Holland	57007409
Taurus	AS214-7409
Watson & Chalin	AS-0093

1/4-18 NPTF: max. 22 lb-ft  
1/2-13 UNC: max. 35 lb-ft  
3/4-16 UNF: max. 50 lb-ft

### FD 330-22 368

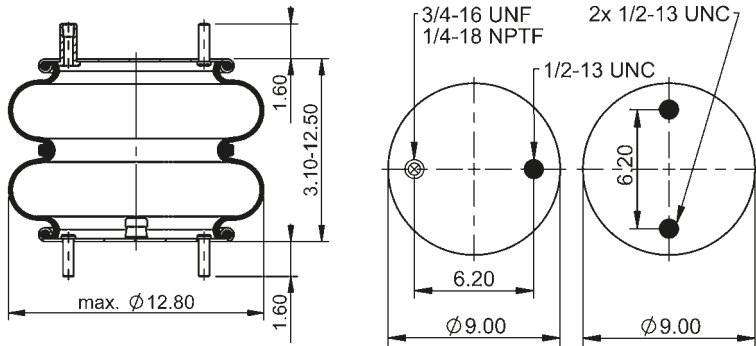

64498



**lb** 13.1 lb

**Cross-reference | Cruce de Referencia**

Firestone	W01-358-7423
Goodyear	2B12-432

**Manufacturer | Fabricante**

Loadguard	SC2101
Navistar/Fleetrite	1681750C1
Sauer	P10-784

1/4-18 NPTF: max. 22 lbft  
 1/2-13 UNC: max. 35 lbft  
 3/4-16 UNF: max. 50 lbft

### FD 330-22 471

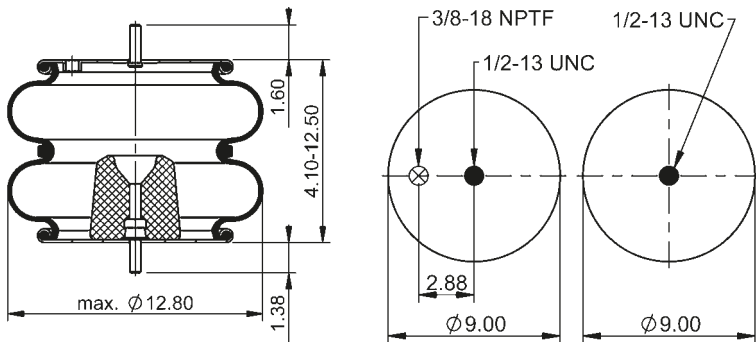

64499



**lb** 14.5 lb

**Cross-reference | Cruce de Referencia**

Firestone	W01-358-7183
Goodyear	2B12-412

**Manufacturer | Fabricante**

Dayton	354-7183
Fruehauf	UCA-0112
	UCA-0112-B
Loadguard	SC2019
Navistar/Fleetrite	554795C1
Ridewell	1003587183C
SAF Holland	57007183
Taurus	AS214-7183

3/8-18 NPTF: max. 22 lbft  
 1/2-13 UNC: max. 35 lbft

### FD 330-22 472

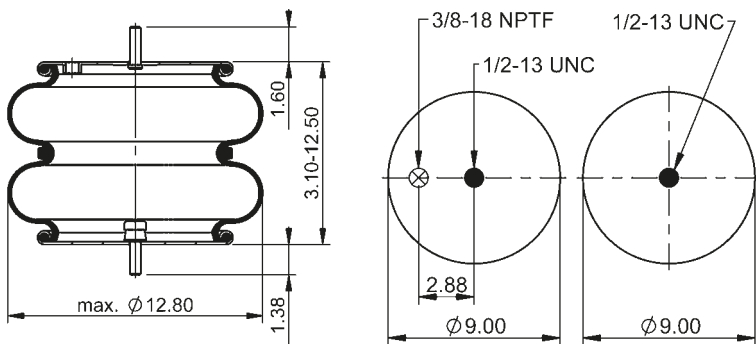

64500



**lb** 13.1 lb

**Cross-reference | Cruce de Referencia**

Firestone	W01-358-7181
Goodyear	2B12-411

**Manufacturer | Fabricante**

Dayton	354-7181
Fruehauf	UAB-5620
	UCC-3054-1
Hendrickson	S-13050
Loadguard	SC2018
Navistar/Fleetrite	554794C1
Ridewell	1003587181C
SAF Holland	57007181
and more	

3/8-18 NPTF: max. 22 lbft  
 1/2-13 UNC: max. 35 lbft

### FD 330-22 500

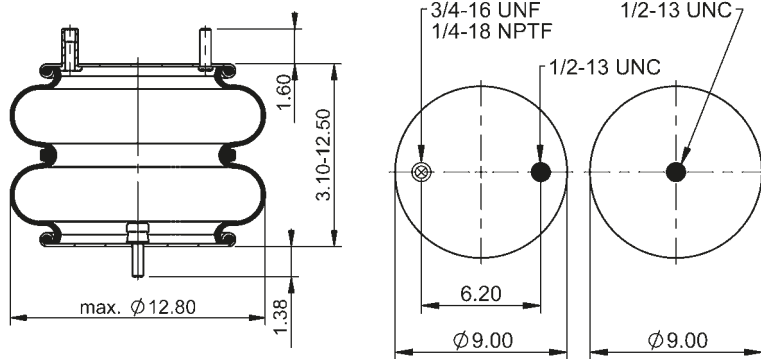

64501



13.1 lb

**Cross-reference | Cruce de Referencia**

Firestone W01-358-7344  
Goodyear 2B12-304

**Manufacturer | Fabricante**

Fixible 6-336-13  
6-336-5  
Load Air P10-755-C  
Sauer P10-755C  
Suspensions, Inc. 200620

- 1/4-18 NPTF: max. 22 lb-ft
- 1/2-13 UNC: max. 35 lb-ft
- 3/4-16 UNF: max. 50 lb-ft

### FD 330-22 540

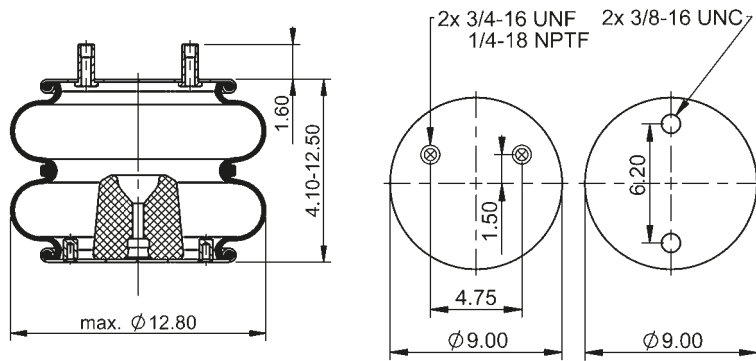

64502



14.5 lb

**Cross-reference | Cruce de Referencia**

Firestone W01-358-6850  
Goodyear 2B12-463

**Manufacturer | Fabricante**

Loadguard SC2130  
Ridewell 1003586850C

- 1/4-18 NPTF: max. 22 lb-ft
- 3/8-16 UNC: max. 20 lb-ft
- 3/4-16 UNF: max. 50 lb-ft

### FD 330-22 780

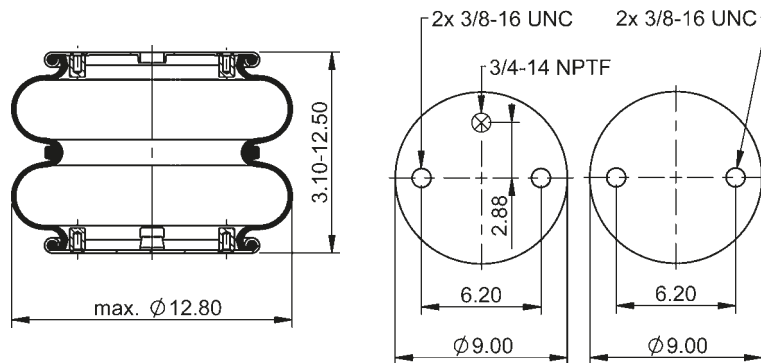

66300



13.1 lb

**Cross-reference | Cruce de Referencia**

Firestone W01-358-7184  
Goodyear 2B12-429

- 3/8-16 UNC: max. 20 lb-ft
- 3/4-14 NPTF: max. 22 lb-ft

Double Convuluted Air Springs | Bolsas de Aire de Dos Cámaras

### FD 330-30 323

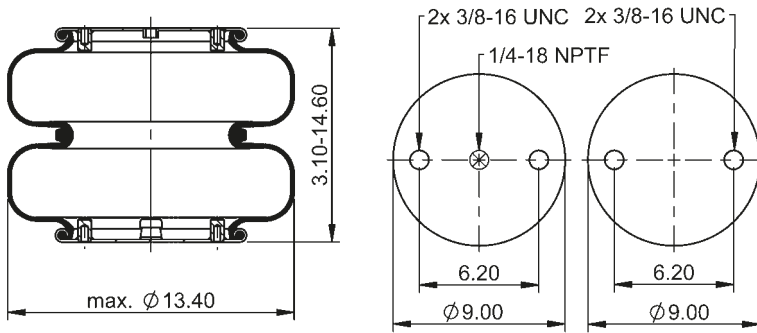

### 64531



**lb** 11.4 lb

#### Cross-reference | Cruce de Referencia

Firestone	W01-358-7443
Goodyear	2B12-305

#### Manufacturer | Fabricante

Granning	1589 1218
Hendrickson	S-13035
Navistar/Fleetrite	554786C1
Ridewell	S2683C 1003587443C
SAF Holland	57007443
Watson & Chalin and more	AS-0027

1/4-18 NPTF: max. 22 lb-ft  
3/8-16 UNC: max. 20 lb-ft

### FD 330-30 340

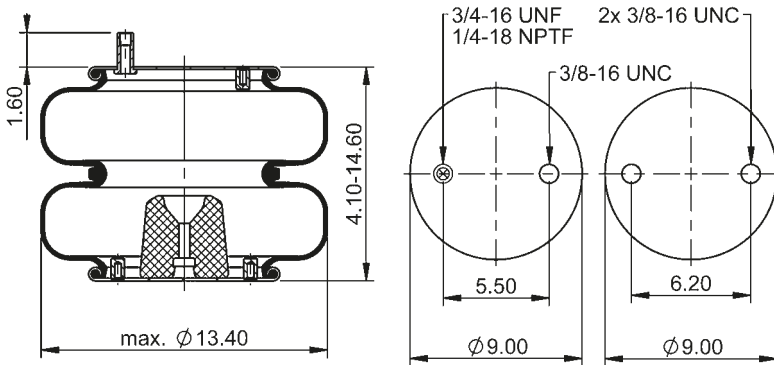

### 64532



**lb** 13.5 lb

#### Cross-reference | Cruce de Referencia

Firestone	W01-358-7447
Goodyear	2B12-324

#### Manufacturer | Fabricante

Dayton	354-7447
EZ Ride	8030150
Hendrickson	S-6242
Loadguard	SC2028
Navistar/Fleetrite	554790C1
Ridewell	1003587447C
SAF Holland	57007447
Tuthill	15698

1/4-18 NPTF: max. 22 lb-ft  
3/8-16 UNC: max. 20 lb-ft  
3/4-16 UNF: max. 50 lb-ft

### FD 330-30 369

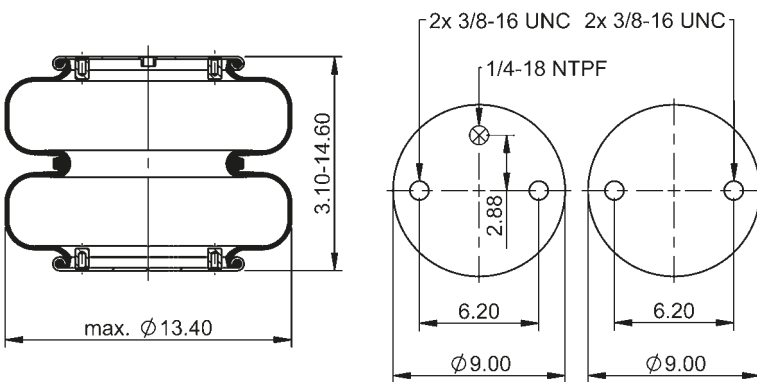

### 64533



**lb** 11.4 lb

#### Cross-reference | Cruce de Referencia

Firestone	W01-358-7444
Goodyear	2B12-446 2B12-416

#### Manufacturer | Fabricante

Hendrickson	S-9830
Ridewell	1003587444C

1/4-18 NPTF: max. 22 lb-ft  
3/8-16 UNC: max. 20 lb-ft

### FD 330-30 370

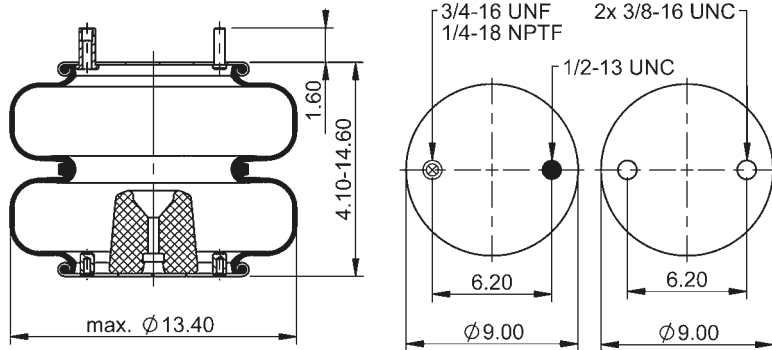

64534



13.6 lb

**Cross-reference | Cruce de Referencia**

Firestone	W01-358-7446
Goodyear	2B12-402

**Manufacturer | Fabricante**

Meritor	201364 201339
Hendrickson	S-3798
Navistar/Fleetrite	554791C1
Ridewell	1003587446C
SAF Holland	57007446
Silent Drive	AS-7446
Watson & Chalin	AS-0005
and more	

1/4-18 NPTF: max. 22 lb-ft  
 3/8-16 UNC: max. 20 lb-ft  
 3/4-16 UNF: max. 50 lb-ft

### FD 330-30 371

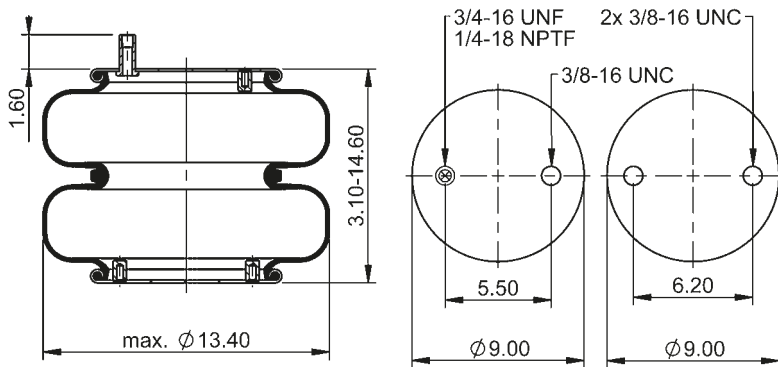

64535



11.3 lb

**Cross-reference | Cruce de Referencia**

Firestone	W01-358-7472
Goodyear	2B12-434

**Manufacturer | Fabricante**

Hendrickson	36514-5 B-12335 S-12514-005
Loadguard	SC2128
Navistar/Fleetrite	1681751C1
SAF Holland	57007472
Sauer	PB10-784
Watson & Chalin	AS-0112

1/4-18 NPTF: max. 22 lb-ft  
 3/8-16 UNC: max. 20 lb-ft  
 3/4-16 UNF: max. 50 lb-ft

### FD 330-30 372

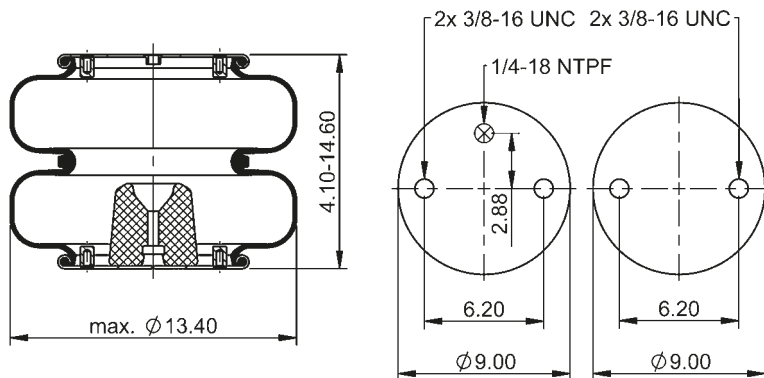

64536



13.5 lb

**Cross-reference | Cruce de Referencia**

Firestone	W01-358-7473
Goodyear	2B12-428

**Manufacturer | Fabricante**

Loadguard	SC2078
Navistar/Fleetrite	1685182C1
Ridewell	1003587473C
SAF Holland	57007473

1/4-18 NPTF: max. 22 lb-ft  
 3/8-16 UNC: max. 20 lb-ft

### FD 330-30 373

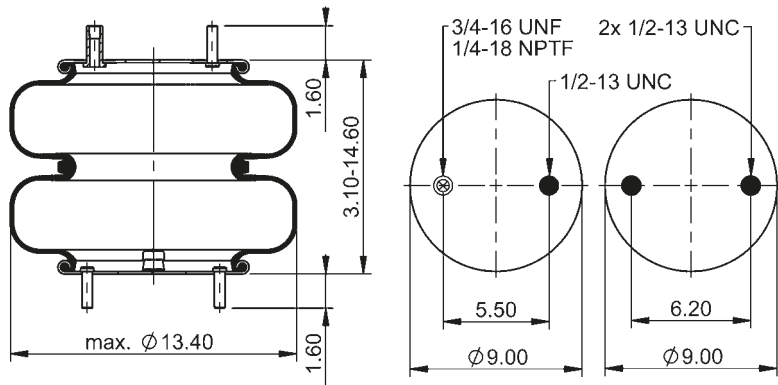

64537



**lb** 11.4 lb

**Cross-reference | Cruce de Referencia**  
Firestone W01-358-7483

**Manufacturer | Fabricante**  
Ridewell 1003587483C

1/4-18 NPTF: max. 22 lb-ft  
1/2-13 UNC: max. 35 lb-ft  
3/4-16 UNF: max. 50 lb-ft

### FD 330-30 502

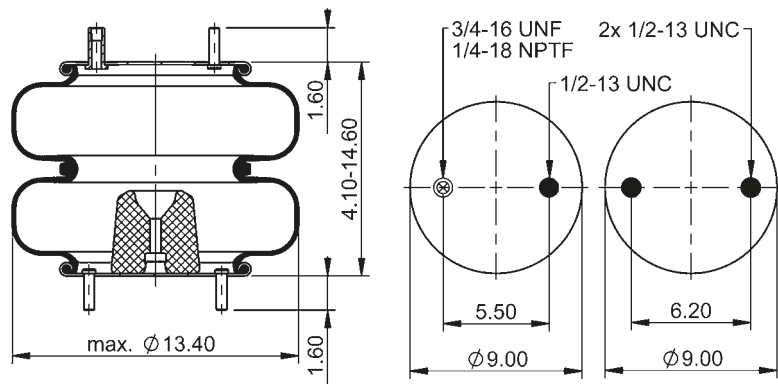

64539



**lb** 13.6 lb

**Cross-reference | Cruce de Referencia**  
Firestone W01-358-7499  
Goodyear 2B12-317

**Manufacturer | Fabricante**  
Meritor 201602  
Suspensions, Inc.

1/4-18 NPTF: max. 22 lb-ft  
1/2-13 UNC: max. 35 lb-ft  
3/4-16 UNF: max. 50 lb-ft

### FD 330-30 512

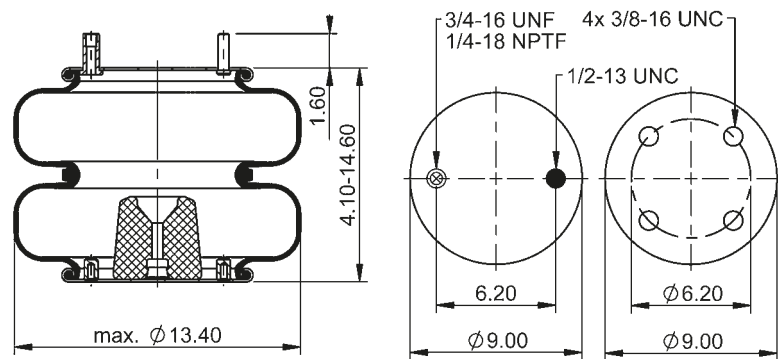

64540



**lb** 13.7 lb

**Cross-reference | Cruce de Referencia**  
Firestone W01-358-6789

**Manufacturer | Fabricante**  
Hendrickson 1503

1/4-18 NPTF: max. 22 lb-ft  
3/8-16 UNC: max. 20 lb-ft  
3/4-16 UNF: max. 50 lb-ft

### FD 330-30 513

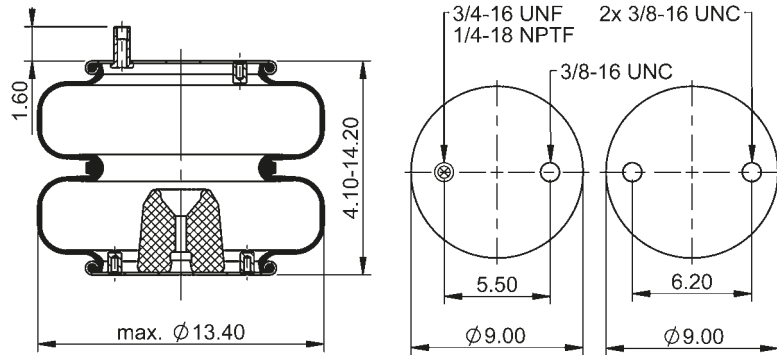

64541



13.5 lb

**Cross-reference | Cruce de Referencia**

Firestone W01-358-7790  
Goodyear 2B12-324

**Manufacturer | Fabricante**

Hendrickson 1475

- 1/4-18 NPTF: max. 22 lb-ft
- 3/8-16 UNC: max. 20 lb-ft
- 3/4-16 UNF: max. 50 lb-ft

### FD 330-30 549

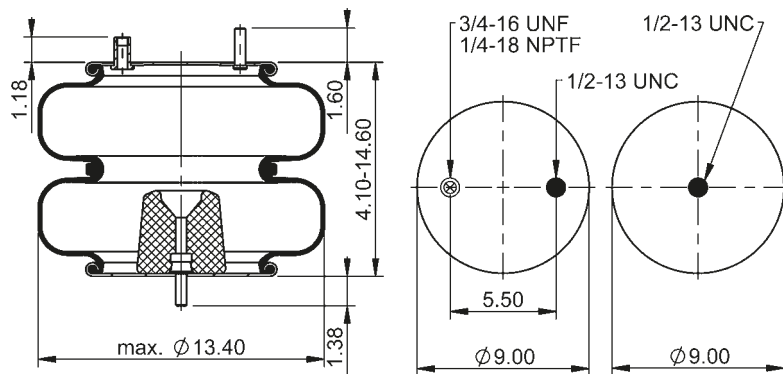

64542



13.6 lb

**Manufacturer | Fabricante**

Raydan 211-00-005

- 1/4-18 NPTF: max. 22 lb-ft
- 1/2-13 UNC: max. 35 lb-ft
- 3/4-16 UNF: max. 50 lb-ft

### FD 330-30 705

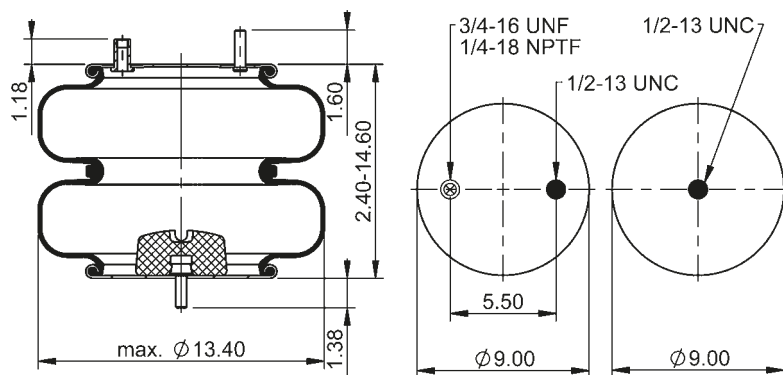

64245



13.9 lb

**Manufacturer | Fabricante**

Raydan 211-00-000

- 1/4-18 NPTF: max. 22 lb-ft
- 1/2-13 UNC: max. 35 lb-ft
- 3/4-16 UNF: max. 50 lb-ft

### FD 331-26 480

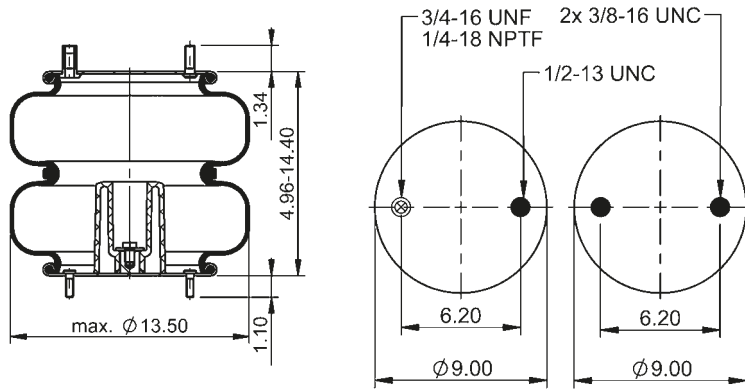

### 64284



**lb** 12.4 lb

#### Cross-reference | Cruce de Referencia

Firestone	W01-358-7555
Goodyear	2B12-440

#### Manufacturer | Fabricante

Binkley	XB-SPN-053-37
Brake & Wheel	M3531
Cush	C-0073
Histeer	10315
Reyco	20018-01 18813-01

1/4-18 NPTF: max. 22 lb-ft  
 3/8-16 UNC: max. 20 lb-ft  
 3/4-16 UNF: max. 50 lb-ft

### FD 331-26 514

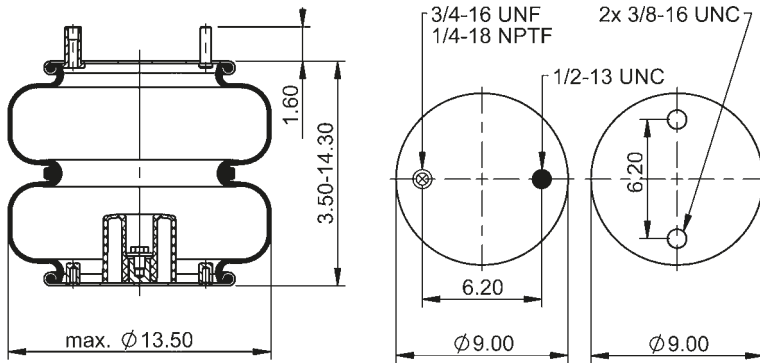

### 64597



**lb** 12.5 lb

#### Cross-reference | Cruce de Referencia

Firestone	W01-358-7545
Goodyear	2B12-345

#### Manufacturer | Fabricante

Hendrickson	1796
Reyco	20018-01L
Watson & Chalin	AS-0087-1F AS-0109

1/4-18 NPTF: max. 22 lb-ft  
 3/8-16 UNC: max. 20 lb-ft  
 3/4-16 UNF: max. 50 lb-ft

### FD 331-26 541

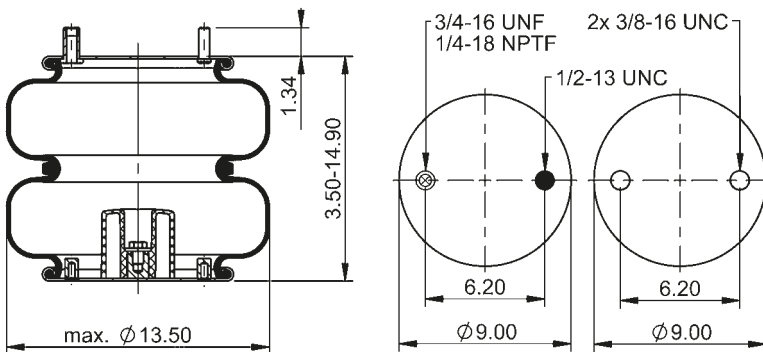

### 64599



**lb** 12.5 lb

#### Cross-reference | Cruce de Referencia

Firestone	W01-358-7550
Goodyear	2B12-346

#### Manufacturer | Fabricante

Histeer	10315
Watson & Chalin	AS-0087

1/4-18 NPTF: max. 22 lb-ft  
 3/8-16 UNC: max. 20 lb-ft  
 3/4-16 UNF: max. 50 lb-ft



### FD 530-22 311

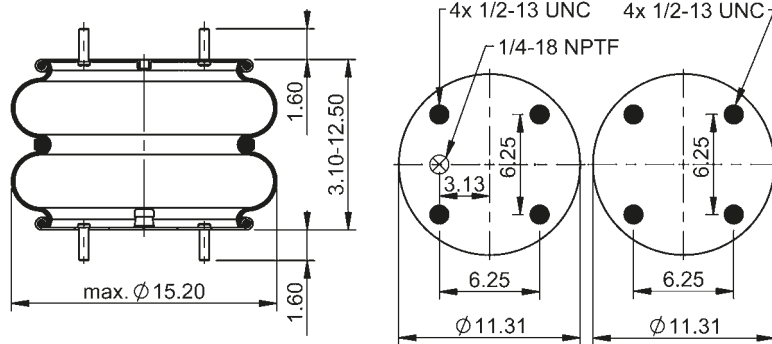

64543



**lb** 17.7 lb

**Cross-reference | Cruce de Referencia**

Firestone	W01-358-7135
Goodyear	2B14-360

**Manufacturer | Fabricante**

Granning	6420
Hendrickson	S-12514-014
	S-13034
Mack	57QL46
Navistar/Fleetrite	554800C1
Ridewell	1003587135C
SAF Holland	90557001
Volvo	3130501
and more	

1/4-18 NPTF: max. 22 lb-ft  
1/2-13 UNC: max. 35 lb-ft

### FD 530-22 316

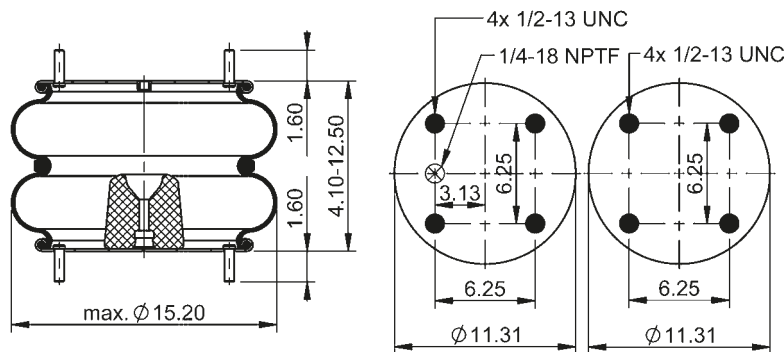

64544



**lb** 20.5 lb

**Cross-reference | Cruce de Referencia**

Firestone	W01-358-7140
Goodyear	2B14-359

**Manufacturer | Fabricante**

Dayton	354-7140
Granning	1015
Hendrickson	S-3184
Loadguard	SC2015
Navistar/Fleetrite	554799C1
SAF Holland	57007140
	90557257
Watson & Chalin	AS-0008
and more	

1/4-18 NPTF: max. 22 lb-ft  
1/2-13 UNC: max. 35 lb-ft

### FD 530-22 321

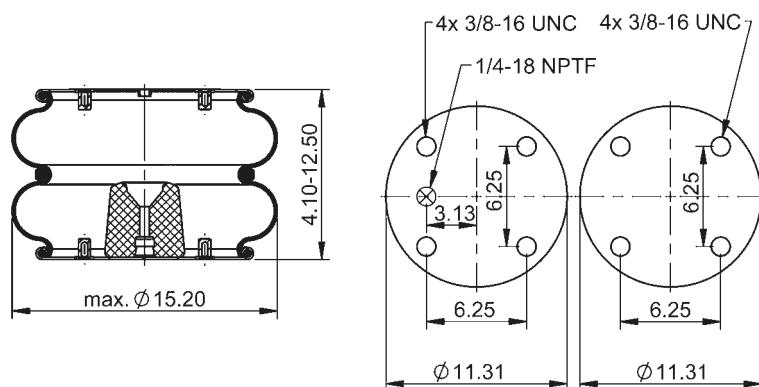

64545



**lb** 20.5 lb

**Cross-reference | Cruce de Referencia**

Firestone	W01-358-7136
Goodyear	2B14-356

**Manufacturer | Fabricante**

Granning	1626
Hendrickson	S-1080
Loadguard	SC2014
Navistar/Fleetrite	554798C1
Ridewell	1003587136C
SAF Holland	57007136
Volvo	3130489
Watson & Chalin	AS-0004
and more	

1/4-18 NPTF: max. 22 lb-ft  
3/8-16 UNC: max. 20 lb-ft

### FD 530-22 342

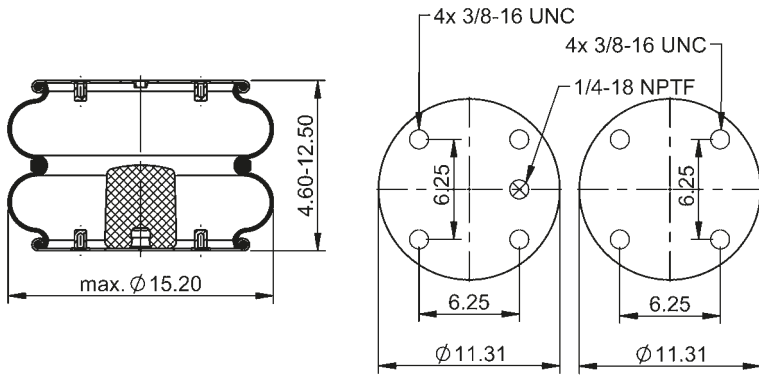

64546



**lb** 20.5 lb

**Cross-reference | Cruce de Referencia**

Firestone	W01-358-7146
Goodyear	2B14-355

**Manufacturer | Fabricante**

American Carrier	8003-005
Dayton	354-7146
Hendrickson	S-13046
Loadguard	SC2017
Navistar/Fleetrite	554797C1
Ridewell	1003587146C
SAF Holland	90557024 90557039

1/4-18 NPTF: max. 22 lb-ft  
3/8-16 UNC: max. 20 lb-ft

### FD 530-22 345

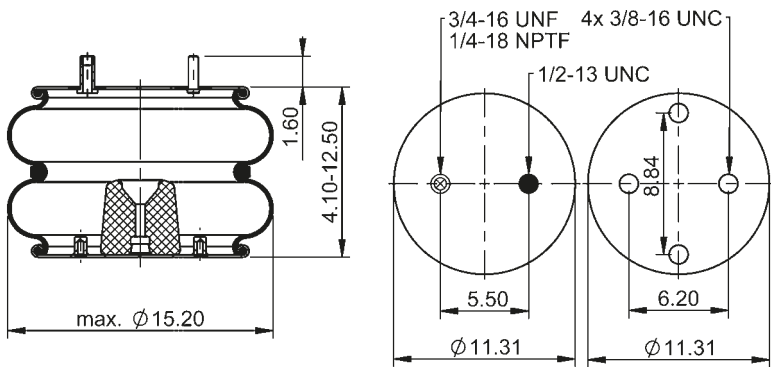

64547



**lb** 20.5 lb

**Cross-reference | Cruce de Referencia**

Firestone	W01-358-7123
Goodyear	2B14-367

**Manufacturer | Fabricante**

Dayton	354-7123
Hendrickson	S-13048
Kwik Loc/Todco	53671
Loadguard	SC2080
Navistar/Fleetrite	1685184C1
Ridewell	1003587123C
SAF Holland	57007123

1/4-18 NPTF: max. 22 lb-ft  
3/8-16 UNC: max. 20 lb-ft  
3/4-16 UNF: max. 50 lb-ft

### FD 530-22 374

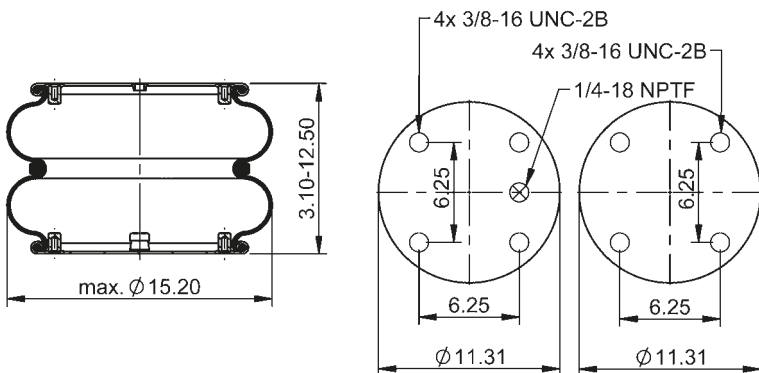

64548



**lb** 17.7 lb

**Cross-reference | Cruce de Referencia**

Firestone	W01-358-7145
Goodyear	2B14-354

**Manufacturer | Fabricante**

Hendrickson	S-13038
Loadguard	SC2016
Mack	57QL239
Navistar/Fleetrite	554796C1
Ridewell	1003587145C
SAF Holland	57007145
Volvo	352033205 352033204

and more

1/4-18 NPTF: max. 22 lb-ft  
3/8-16 UNC: max. 20 lb-ft

### FD 530-30 449

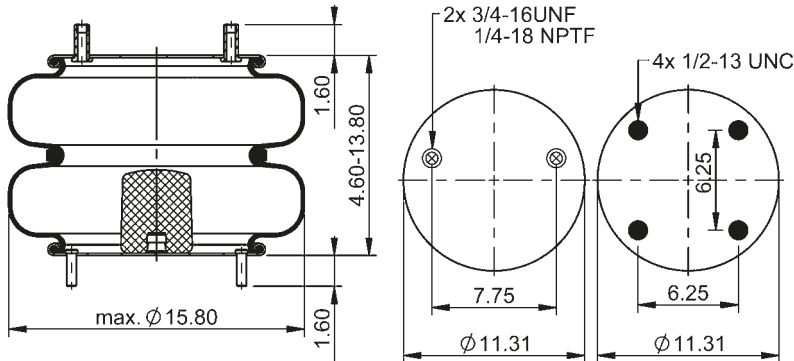

64589



21.2 lb

**Cross-reference | Cruce de Referencia**

Firestone	W01-358-6803
Goodyear	2B14-366

**Manufacturer | Fabricante**

Dayton	354-6803
Hendrickson	S-6412
Loadguard	SC2129
SAF Holland	57006803

1/4-18 NPTF: max. 22 lb-ft  
 1/2-13 UNC: max. 35 lb-ft  
 3/4-16 UNF: max. 50 lb-ft

### FD 530-30 451

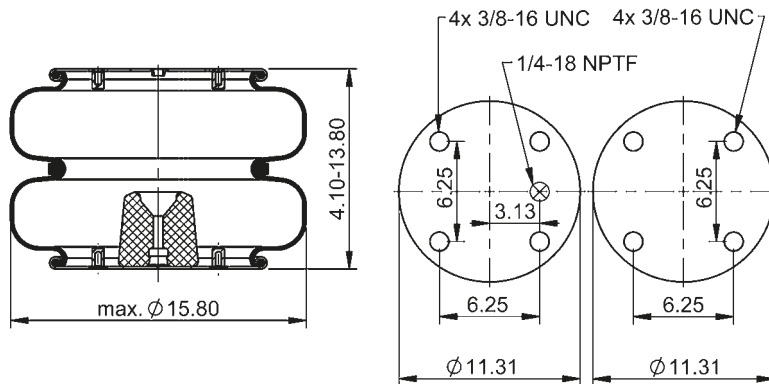

64590



21.2 lb

**Cross-reference | Cruce de Referencia**

Firestone	W01-358-6801
Goodyear	2B14-365

**Manufacturer | Fabricante**

Meritor	201377
Dayton	354-6801
Hendrickson	S-2734
Loadguard	SC2079
Navistar/Fleetrite	1685183C1
Ridwell	1003586801C
SAF Holland	57006801
Watson & Chalin	AS-0021
and more	

1/4-18 NPTF: max. 22 lb-ft  
 3/8-16 UNC: max. 20 lb-ft

### FD 530-30 518

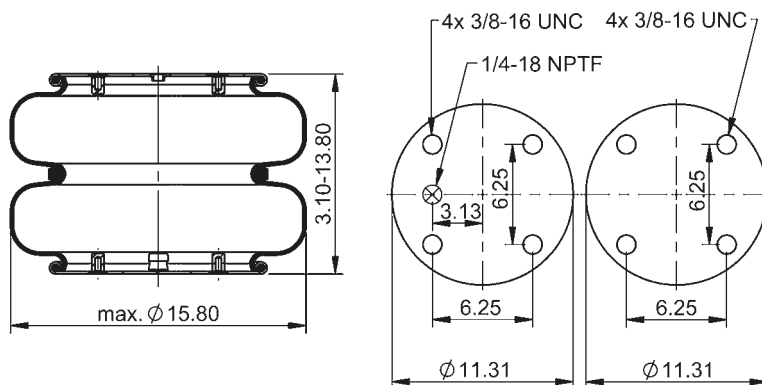

64591



17.9 lb

**Cross-reference | Cruce de Referencia**

Firestone	W01-358-6800
Goodyear	2B14-362

1/4-18 NPTF: max. 22 lb-ft  
 3/8-16 UNC: max. 20 lb-ft

### FD 530-30 519

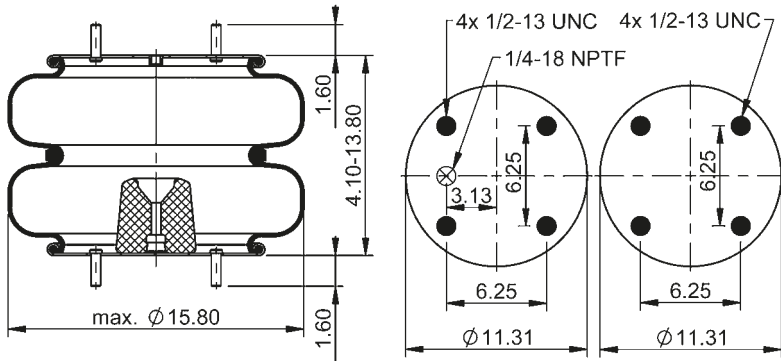

64592



**lb** 21.2 lb

**Cross-reference | Cruce de Referencia**  
Firestone W01-358-6808

**Manufacturer | Fabricante**  
Tuthill 11332  
15664  
Watson & Chalin AS-0034

1/4-18 NPTF: max. 22 lb-ft  
1/2-13 UNC: max. 35 lb-ft

### FD 530-30 532

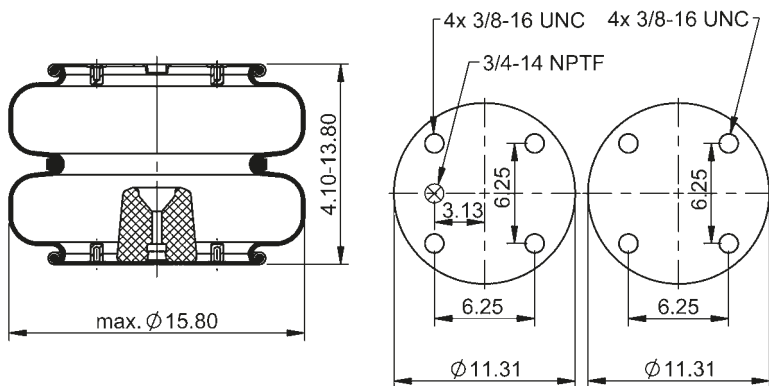

64593



**lb** 21.2 lb

**Cross-reference | Cruce de Referencia**  
Firestone W01-358-6805  
Goodyear 2B14-462

**Manufacturer | Fabricante**  
Ridewell 1003586805C

3/8-16 UNC: max. 20 lb-ft  
3/4-14 NPTF: max. 22 lb-ft

### FD 530-30 707

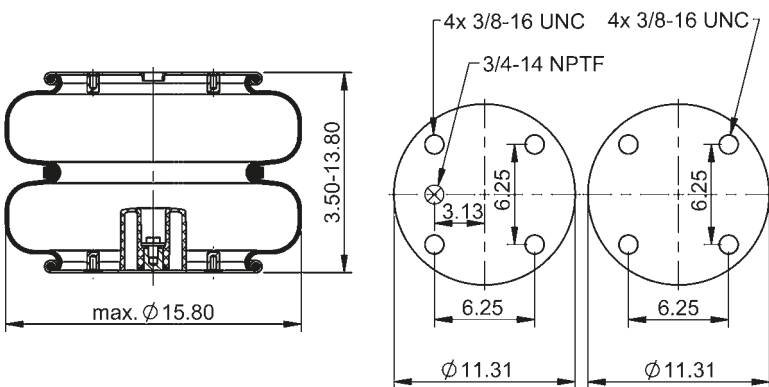

64676



**lb** 17.5 lb

**Manufacturer | Fabricante**  
Watson & Chalin AS-0123-G

3/8-16 UNC: max. 20 lb-ft  
3/4-14 NPTF: max. 22 lb-ft

### FD 530-35 530

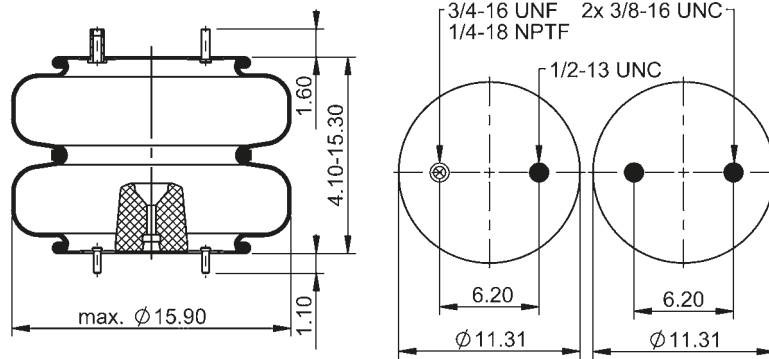

64604



20.5 lb

**Cross-reference | Cruce de Referencia**

Firestone W01-358-7557  
Goodyear 2B14-383

**Manufacturer | Fabricante**

Histeer 10316  
Reyco 19983-01  
Watson & Chalin AS-0089-1G

- 1/4-18 NPTF: max. 22 lbft
- 3/8-16 UNC: max. 20 lbft
- 3/4-16 UNF: max. 50 lbft

### FD 530-35 543

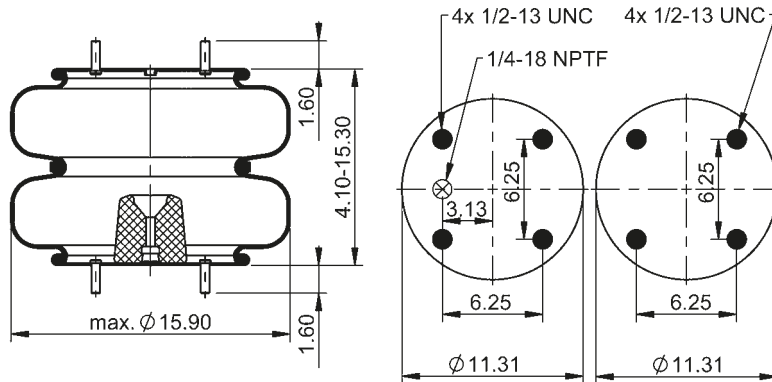

64605



20.8 lb

**Cross-reference | Cruce de Referencia**

Firestone W01-358-6799  
Goodyear 2B14-476

**Manufacturer | Fabricante**

SAF Holland 90557203

- 1/4-18 NPTF: max. 22 lbft
- 1/2-13 UNC: max. 35 lbft

### FD 530-35 544

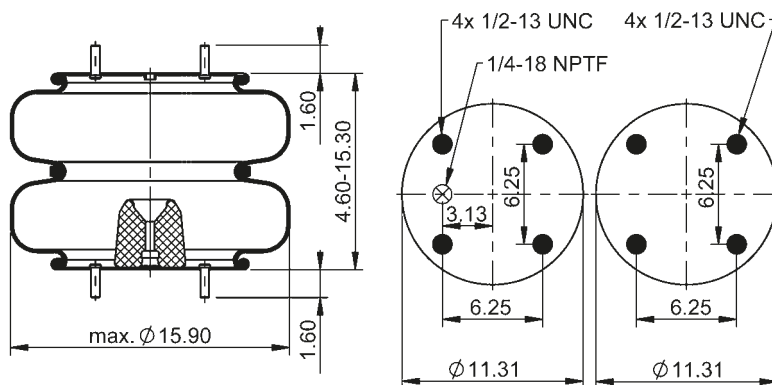

64606



20.8 lb

**Cross-reference | Cruce de Referencia**

Firestone W01-358-7782  
Goodyear 2B14-470

**Manufacturer | Fabricante**

Watson & Chalin AS-0032

- 1/4-18 NPTF: max. 22 lbft
- 1/2-13 UNC: max. 35 lbft

### FD 530-35 545

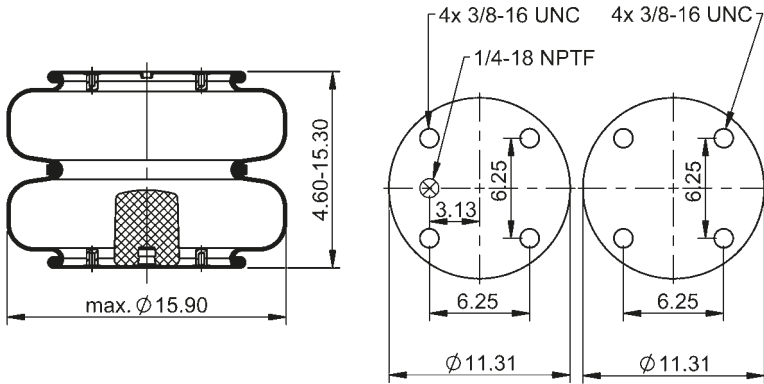

64607



**lb** 20.2 lb

**Cross-reference | Cruce de Referencia**  
Firestone W01-358-7781

**Manufacturer | Fabricante**  
Cush C-0083  
Ridewell 1003587781C

1/4-18 NPTF: max. 22 lb-ft  
3/8-16 UNC: max. 20 lb-ft

### FD 530-35 720

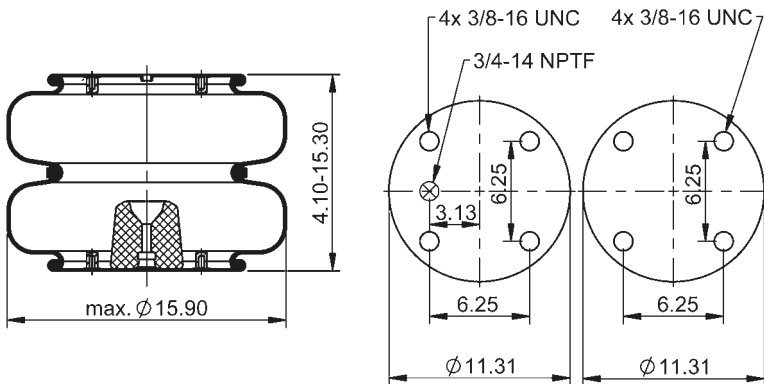

64623



**lb** 18.9 lb

**Manufacturer | Fabricante**  
Watson & Chalin AS-0110-G

3/8-16 UNC: max. 20 lb-ft  
3/4-14 NPTF: max. 22 lb-ft

### FD 530-35 912

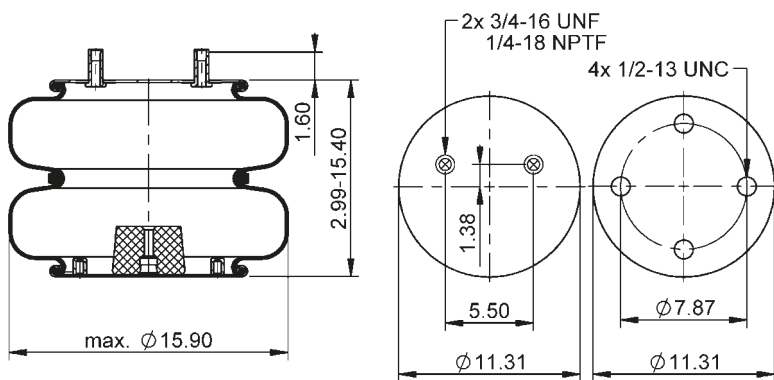

78235



**lb** 18.1 lb

**Manufacturer | Fabricante**  
SAF Holland 90557423

1/4-18 NPTF: max. 22 lb-ft  
1/2-13 UNC: max. 35 lb-ft  
3/4-16 UNF: max. 50 lb-ft

### FD 530-35 1165

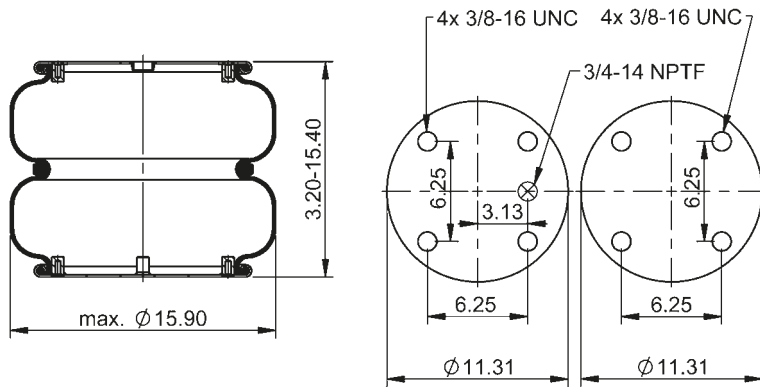

77199



**lb** 15.7 lb

**Cross-reference | Cruce de Referencia**

Firestone W01-358-9529  
Goodyear 2B14-363

3/8-16 UNC: max. 18 lb-ft  
3/4-14 NPTF: max. 22 lb-ft

### FD 530-35 1316

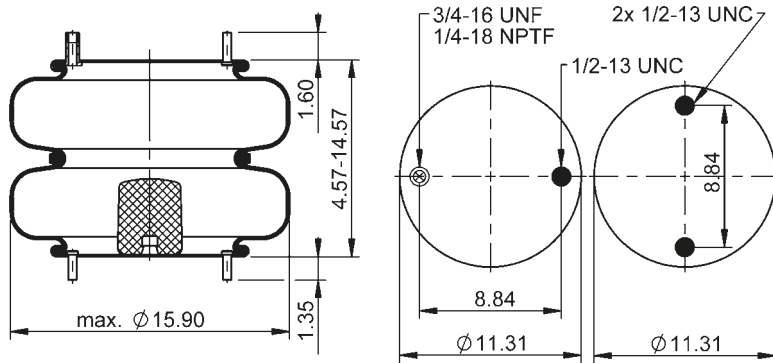

600554



**lb** 17.7 lb

**Cross-reference | Cruce de Referencia**

Goodyear 2B14-385

1/4-18 NPTF: max. 2 lb-ft  
1/2-13 UNC: max. 35 lb-ft  
3/4-16 UNF: max. 50 lb-ft





# Triple Convoluted Air Springs

Bolsas de Aire de Tres Cámaras



Triple Convoluted Air Springs |  
Bolsas de Aire de Tres Cámaras

### FT 330-29 413

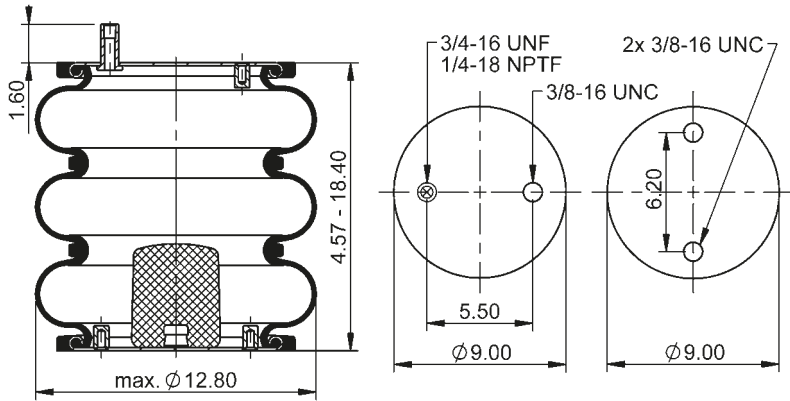

### 64560



**lb** 15.3 lb

#### Cross-reference | Cruce de Referencia

Firestone	W01-358-8032
Goodyear	3B12-319

#### Manufacturer | Fabricante

Hendrickson	S-12405
Ridewell	1003588032C
Spring Valley	AS-4413

1/4-18 NPTF: max. 22 lb-ft  
 3/8-16 UNC: max. 20 lb-ft  
 3/4-16 UNF: max. 50 lb-ft

### FT 330-29 430

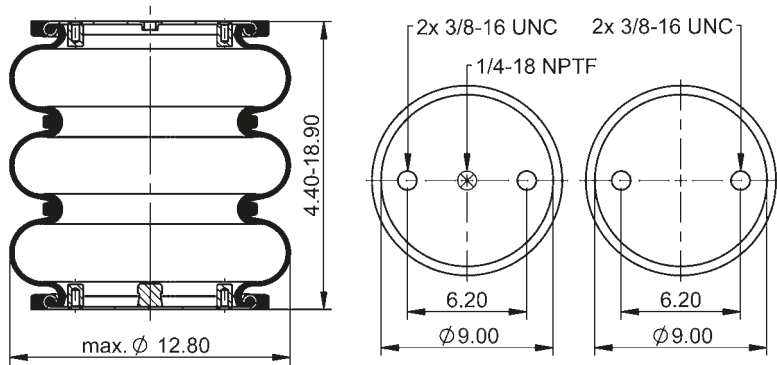

### 64561



**lb** 13.4 lb

#### Cross-reference | Cruce de Referencia

Firestone	W01-358-8006
-----------	--------------

1/4-18 NPTF: max. 22 lb-ft  
 3/8-16 UNC: max. 20 lb-ft

### FT 330-29 431

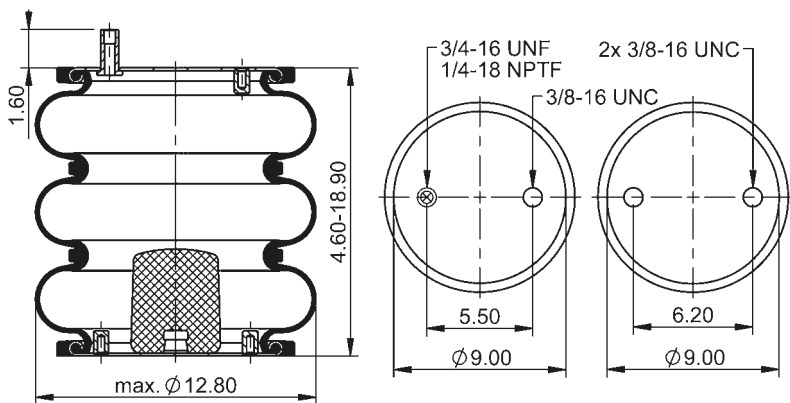

### 64562



**lb** 15.3 lb

#### Cross-reference | Cruce de Referencia

Firestone	W01-358-8008
Goodyear	3B12-300

#### Manufacturer | Fabricante

Dayton	354-8008
EZ Ride	8030155
Granning	6392
Hendrickson	S-11637
Loadguard	SC2130
Ridewell	1003588008C
SAF Holland	57008008
Tuthill	6392

1/4-18 NPTF: max. 22 lb-ft  
 3/8-16 UNC: max. 20 lb-ft  
 3/4-16 UNF: max. 50 lb-ft

### FT 330-29 432

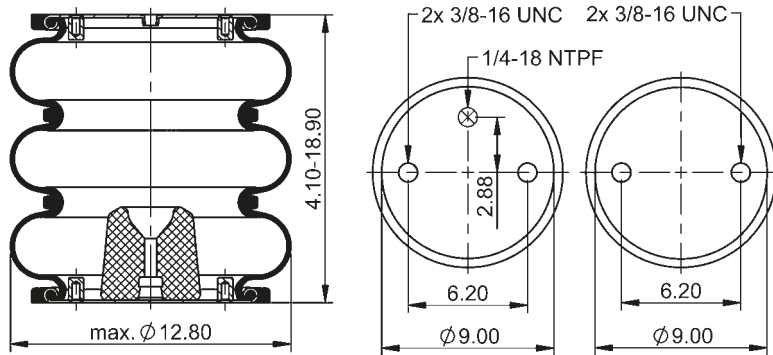

64563



15.6 lb

**Cross-reference | Cruce de Referencia**  
 Firestone W01-358-8010

**Manufacturer | Fabricante**  
 Loadguard SC2119  
 Oshkosh 8013  
 Ridewell S5844C  
 1003588010C

1/4-18 NPTF: max. 22 lb-ft  
 3/8-16 UNC: max. 20 lb-ft

### FT 330-29 433

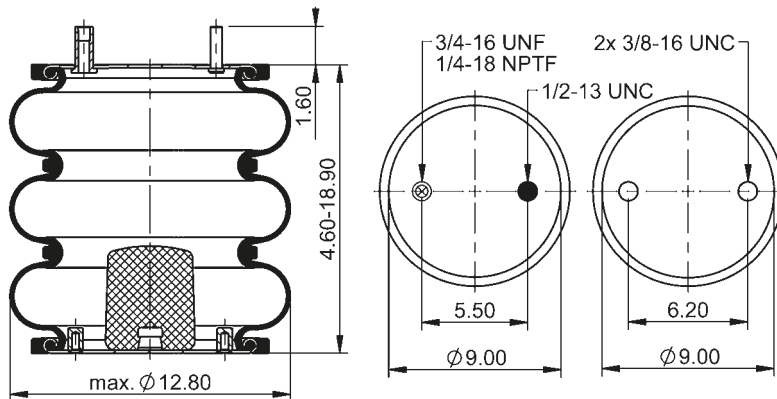

64564



15.4 lb

**Cross-reference | Cruce de Referencia**  
 Firestone W01-358-8016

**Manufacturer | Fabricante**  
 Ridewell 1003588016C

1/4-18 NPTF: max. 22 lb-ft  
 3/8-16 UNC: max. 20 lb-ft  
 3/4-16 UNF: max. 50 lb-ft

### FT 330-29 434

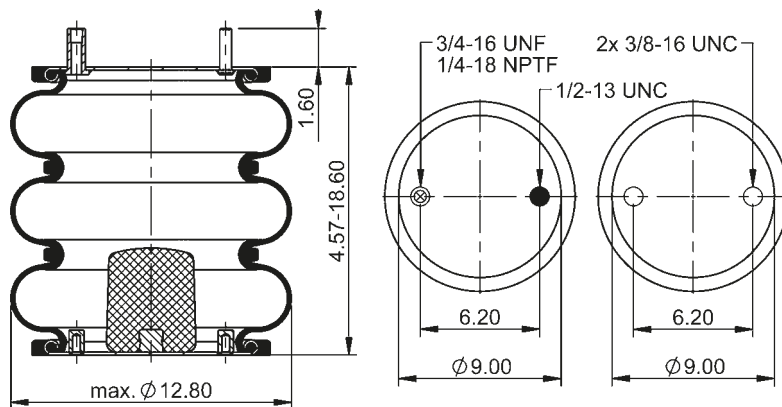

64285



15.4 lb

**Cross-reference | Cruce de Referencia**  
 Firestone W01-358-8018  
 Goodyear 3B12-303

**Manufacturer | Fabricante**  
 Meritor 202394  
 Granning 6393  
 Loadguard SC2131  
 Reyco 93AR  
 Ridewell 1003588018C  
 Spring Valley AS-4434  
 Tuthill 6393  
 Watson & Chalin AS-0075  
 and more

1/4-18 NPTF: max. 22 lb-ft  
 3/8-16 UNC: max. 20 lb-ft  
 3/4-16 UNF: max. 50 lb-ft

### FT 330-29 466

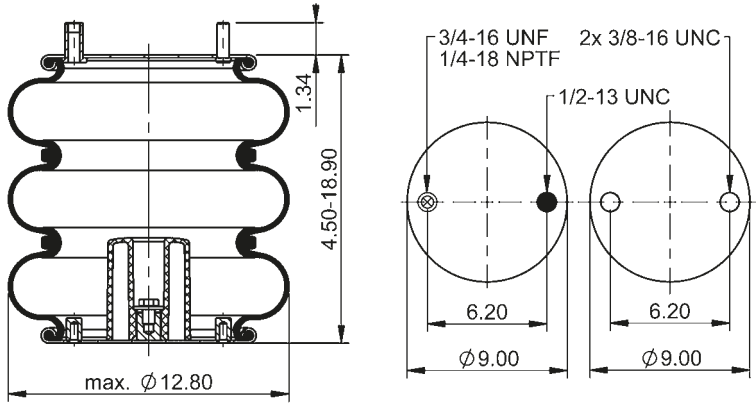

### 64565



**lb** 14.2 lb

#### Cross-reference | Cruce de Referencia

Firestone	W01-358-8027
Goodyear	3B12-310

#### Manufacturer | Fabricante

Meritor	200117
Seats	
Suspensions, Inc.	

- 1/4-18 NPTF: max. 22 lb-ft
- 3/8-16 UNC: max. 20 lb-ft
- 3/4-16 UNF: max. 50 lb-ft

### FT 330-29 469

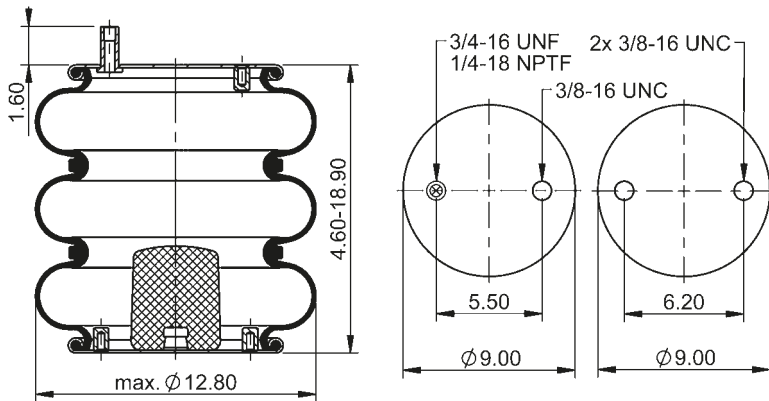

### 64566



**lb** 14.7 lb

#### Cross-reference | Cruce de Referencia

Firestone	W01-358-8025
-----------	--------------

#### Manufacturer | Fabricante

Dayton	354-8008
Loadguard	SC2130
Silent Drive	AS-8025
Watson & Chalin	AS-0019

- 1/4-18 NPTF: max. 22 lb-ft
- 3/8-16 UNC: max. 20 lb-ft
- 3/4-16 UNF: max. 50 lb-ft

### FT 330-29 498

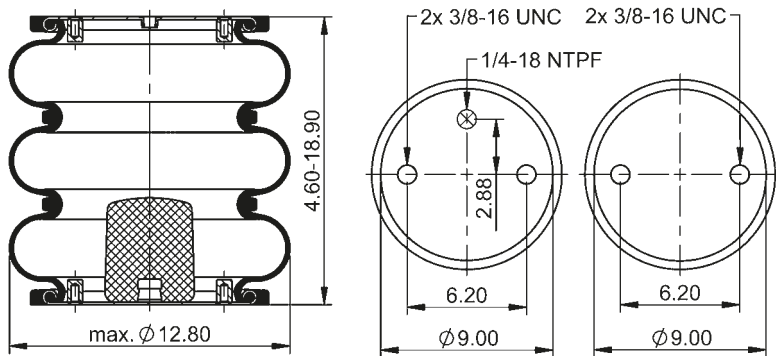

### 64567



**lb** 15.3 lb

#### Cross-reference | Cruce de Referencia

Firestone	W01-358-8030
Goodyear	3B12-301

#### Manufacturer | Fabricante

Ridewell	1003588030C
----------	-------------

- 1/4-18 NPTF: max. 22 lb-ft
- 3/8-16 UNC: max. 20 lb-ft

### FT 330-29 503

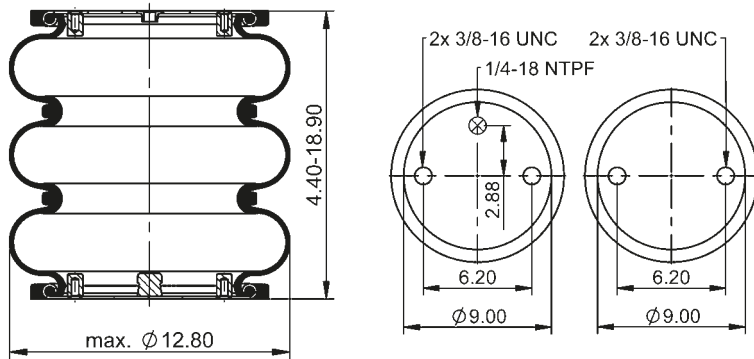

64568



**lb** 13.4 lb

**Cross-reference | Cruce de Referencia**

Goodyear 3B12-304

**Manufacturer | Fabricante**

Loadguard SC2132  
Suspensions, Inc. 200620

1/4-18 NPTF: max. 22 lb-ft  
3/8-16 UNC: max. 20 lb-ft

### FT 330-29 520

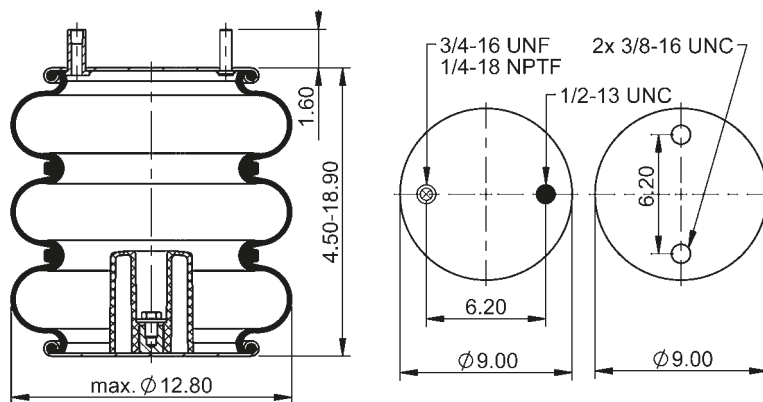

64570



**lb** 14.1 lb

**Cross-reference | Cruce de Referencia**

Firestone W01-358-7996  
Goodyear 3B12-335

**Manufacturer | Fabricante**

Granning 702932-01  
8221

1/4-18 NPTF: max. 22 lb-ft  
3/8-16 UNC: max. 20 lb-ft  
3/4-16 UNF: max. 50 lb-ft

### FT 330-29 525

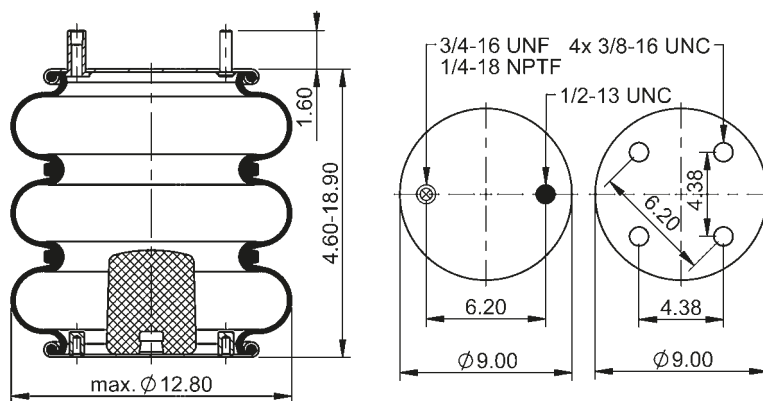

64571



**lb** 14.9 lb

**Cross-reference | Cruce de Referencia**

Firestone W01-358-8033  
Goodyear 3B12-312

**Manufacturer | Fabricante**

Hendrickson B-14487  
3316  
Loadguard SC2784  
Watson & Chalin AS-0168-G

1/4-18 NPTF: max. 22 lb-ft  
3/8-16 UNC: max. 20 lb-ft  
3/4-16 UNF: max. 50 lb-ft

### FT 330-29 546

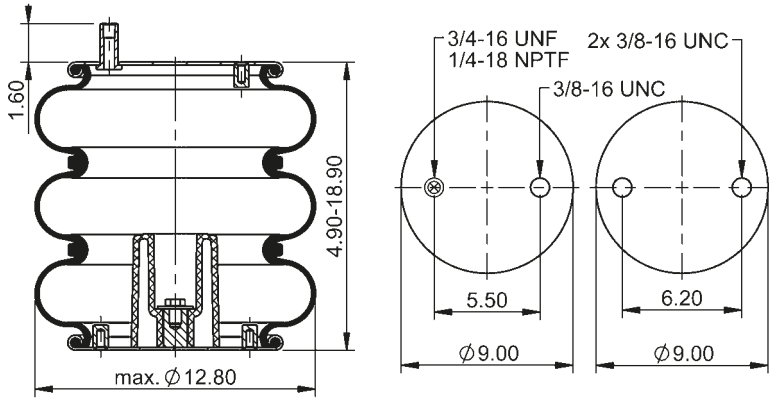

64572



**lb** 14.3 lb

**Cross-reference | Cruce de Referencia**

Firestone W01-358-7994  
Goodyear 3B12-328

**Manufacturer | Fabricante**

Watson & Chalin AS-0019-1F

- 1/4-18 NPTF: max. 22 lb-ft
- 3/8-16 UNC: max. 20 lb-ft
- 3/4-16 UNF: max. 50 lb-ft

### FT 330-29 547

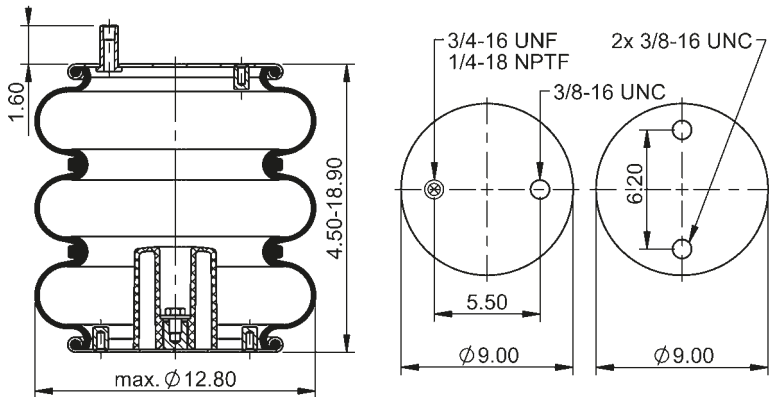

64573



**lb** 14.1 lb

**Cross-reference | Cruce de Referencia**

Firestone W01-358-7995  
Goodyear 3B12-315

**Manufacturer | Fabricante**

Watson & Chalin AS-0048-1F

- 1/4-18 NPTF: max. 22 lb-ft
- 3/8-16 UNC: max. 20 lb-ft
- 3/4-16 UNF: max. 50 lb-ft

### FT 330-29 548

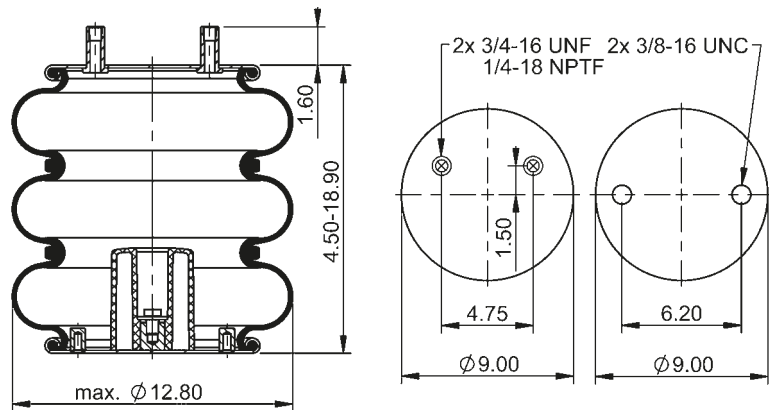

64574



**lb** 14.2 lb

**Cross-reference | Cruce de Referencia**

Firestone W01-358-7998

**Manufacturer | Fabricante**

Hendrickson 1560

- 1/4-18 NPTF: max. 22 lb-ft
- 3/8-16 UNC: max. 20 lb-ft
- 3/4-16 UNF: max. 50 lb-ft

### FT 330-29 554

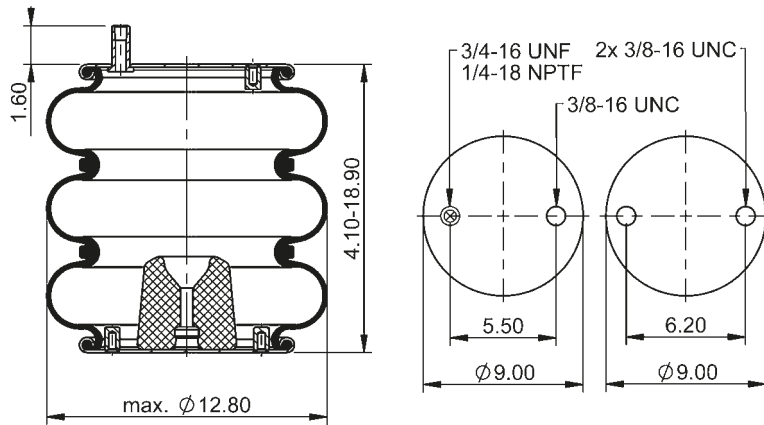

66522



**lb** 15.1 lb

**Cross-reference | Cruce de Referencia**

Firestone	W01-358-8038
Goodyear	3B12-415

**Manufacturer | Fabricante**

Histeer	10313
Longer Stroke	8008

- 1/4-18 NPTF: max. 22 lb-ft
- 3/8-16 UNC: max. 20 lb-ft
- 3/4-16 UNF: max. 50 lb-ft

### FT 330-29 703

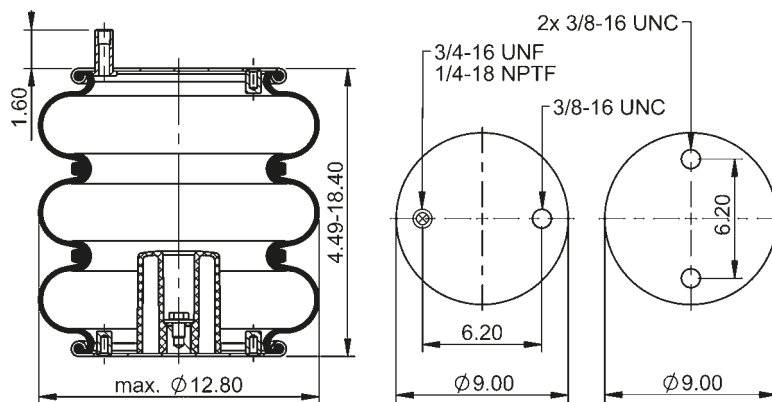

64648



**lb** 14.1 lb

**Cross-reference | Cruce de Referencia**

Firestone	W01-358-7990
Goodyear	3B12-329
	3B12-324

**Manufacturer | Fabricante**

Watson & Chalin	AS-0048
	AS-0048-2G

- 1/4-18 NPTF: max. 22 lb-ft
- 3/8-16 UNC: max. 20 lb-ft
- 3/4-16 UNF: max. 50 lb-ft

### FT 330-29 714

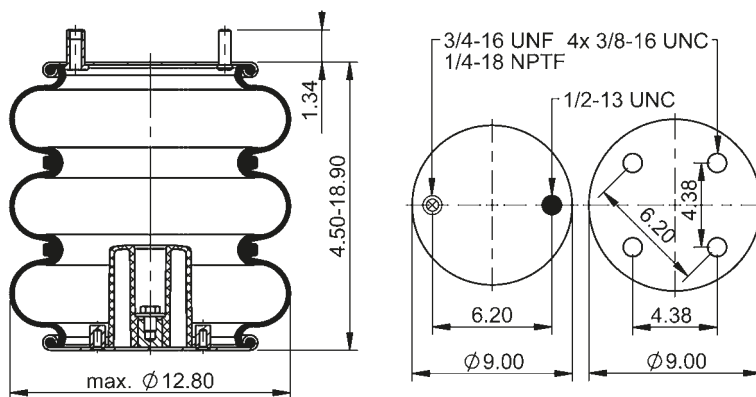

67904



**lb** 14.1 lb

**Cross-reference | Cruce de Referencia**

Firestone	W01-358-8033
-----------	--------------

**Manufacturer | Fabricante**

Hendrickson	B-14487
-------------	---------

- 1/4-18 NPTF: max. 22 lb-ft
- 3/8-16 UNC: max. 20 lb-ft
- 3/4-16 UNF: max. 50 lb-ft

### FT 330-29 722

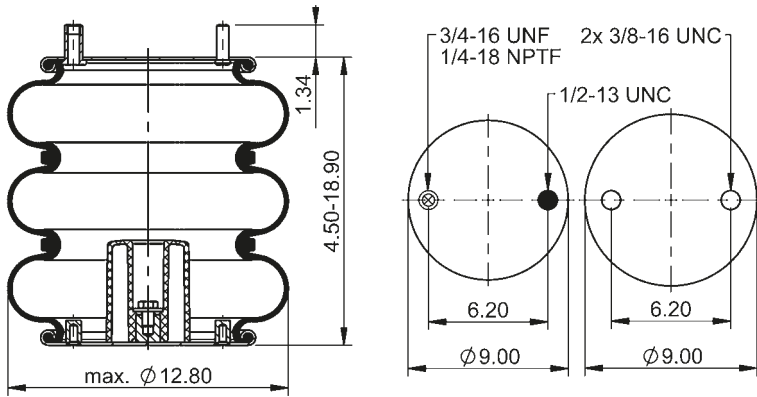

64709



**lb** 14.2 lb

**Manufacturer | Fabricante**

Link 1103-0003

- 1/4-18 NPTF: max. 22 lb-ft
- 3/8-16 UNC: max. 20 lb-ft
- 3/4-16 UNF: max. 50 lb-ft

### FT 330-29 723

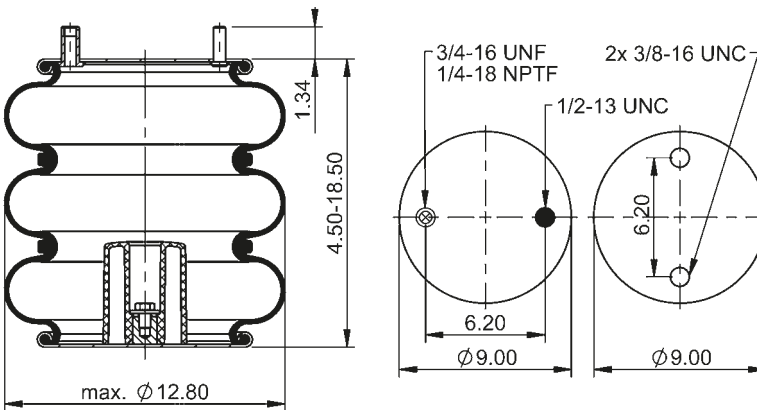

64710



**lb** 14.2 lb

**Cross-reference | Cruce de Referencia**

Firestone W01-358-7996  
Goodyear 3B12-335

**Manufacturer | Fabricante**

Link 1103-0056

- 1/4-18 NPTF: max. 22 lb-ft
- 3/8-16 UNC: max. 20 lb-ft
- 3/4-16 UNF: max. 50 lb-ft

### FT 330-29 773

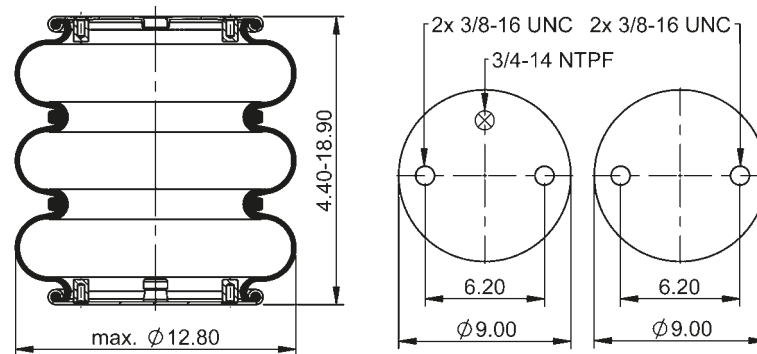

65978



**lb** 13.7 lb

**Manufacturer | Fabricante**

MAC 2380 Z14

- 3/8-16 UNC: max. 20 lb-ft
- 3/4-14 NPTF: max. 22 lb-ft



### FT 330-29 790

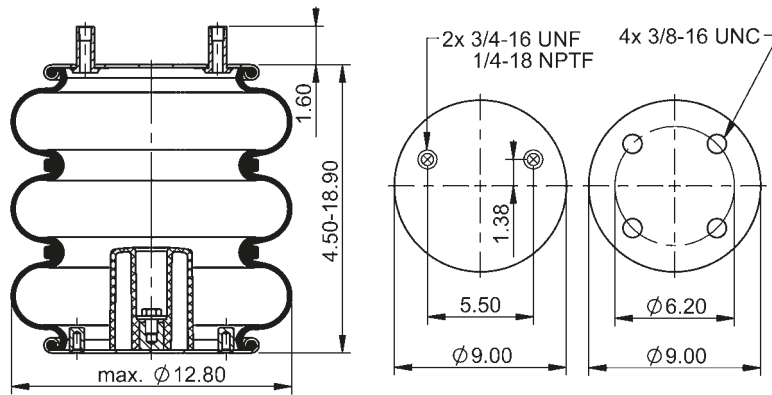

69747



15.1 lb

**Cross-reference | Cruce de Referencia**

Firestone W01-358-8042  
Goodyear 3B12-322

**Manufacturer | Fabricante**

Hendrickson 1015  
SAF Holland 90557236

$1/4-18$  NPTF: max. 22 lb-ft  
 $3/4-16$  UNC: max. 20 lb-ft  
 $3/4-16$  UNF: max. 50 lb-ft

### FT 330-29 821

**new**

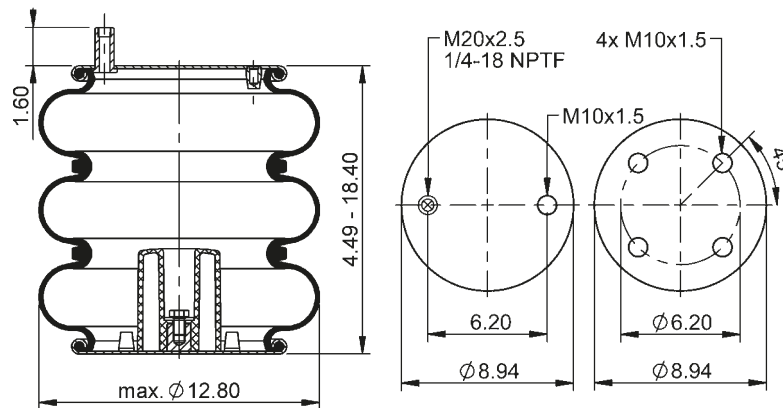

70123



13.7 lb

**Manufacturer | Fabricante**

Hendrickson 10343

$1/4-18$  NPTF: max. 22 lb-ft  
M20x2.5: max. 40 lb-ft

### FT 330-29 874

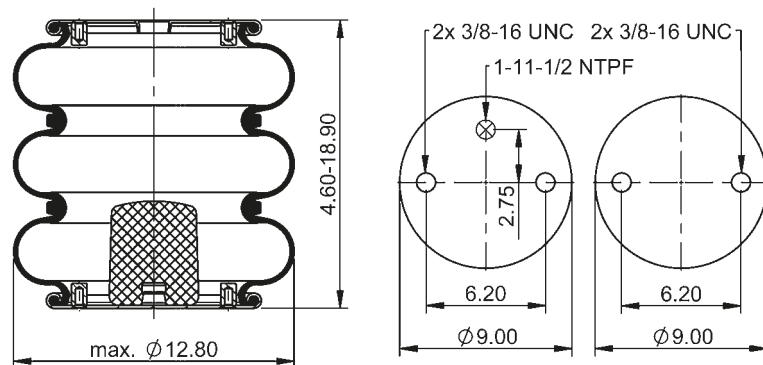

69630



13.4 lb

**Cross-reference | Cruce de Referencia**

Firestone W01-358-8014

**Manufacturer | Fabricante**

Ridewell 1003588014C

$3/8-16$  UNC: max. 20 lb-ft  
1 NPTF: max. 22 lb-ft

### FT 330-29 875

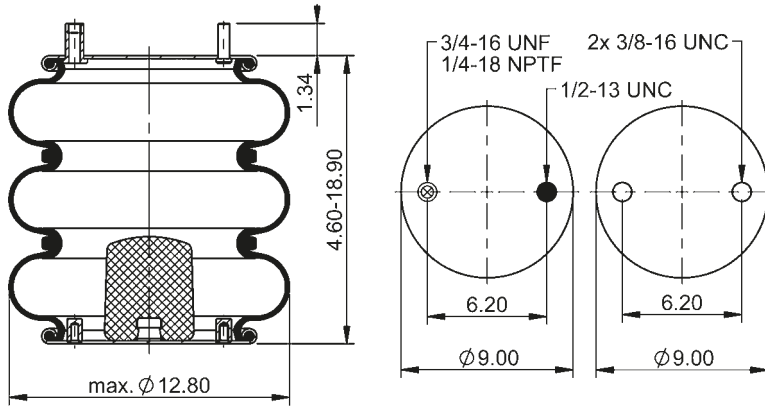

69641



**lb** 15.0 lb

**Cross-reference | Cruce de Referencia**

Firestone	W01-358-8039
Goodyear	3B12-416

**Manufacturer | Fabricante**

Histeer	10303
Longer Stroke	8018

- 1/4-18 NPTF: max. 22 lb-ft
- 3/8-16 UNC: max. 20 lb-ft
- 3/4-16 UNF: max. 50 lb-ft

### FT 330-29 1007

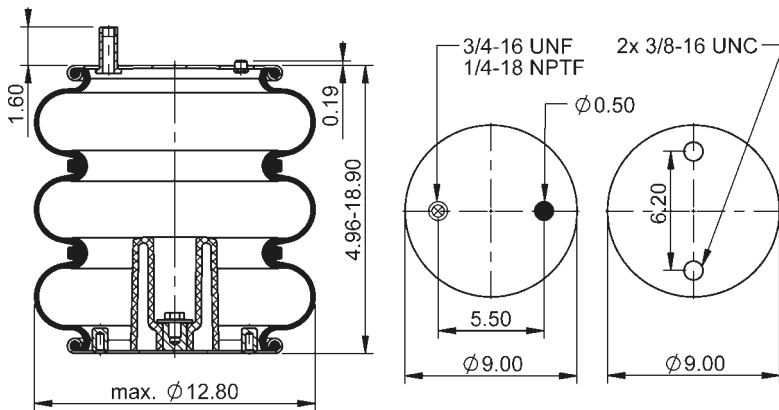

75142



**lb** 15.0 lb

**Cross-reference | Cruce de Referencia**

Goodyear	3B12-338
----------	----------

**Manufacturer | Fabricante**

Ridewell	1003B12338G
----------	-------------

- 1/4-18 NPTF: max. 22 lb-ft
- 3/8-16 UNC: max. 20 lb-ft
- 3/4-16 UNF: max. 50 lb-ft

### FT 430-35 1178

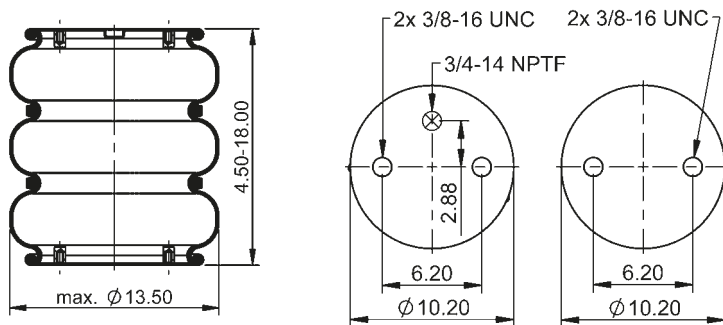

77340



**lb** 15.3 lb

**Cross-reference | Cruce de Referencia**

Firestone	W01-358-8047
Goodyear	3B12-326

- 3/8-16 UNC: max. 18 lb-ft
- 3/4-14 NPTF: max. 22 lb-ft

### FT 430-35 1188

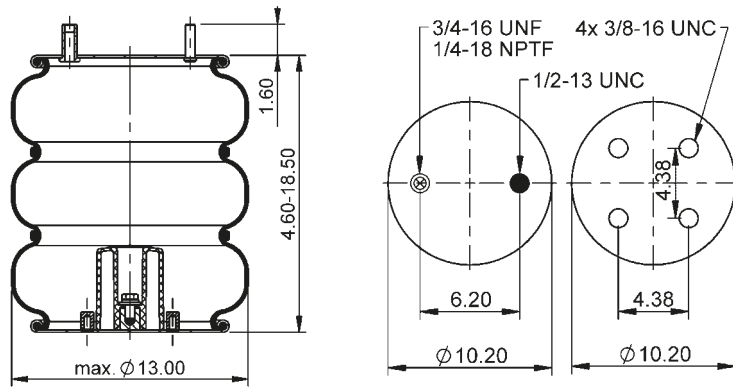

78687



16.9 lb

**Cross-reference | Cruce de Referencia**

Goodyear 3B12-323

- 1/4-18 NPTF: max. 18 lb-ft
- 1/2-13 UNC: max. 35 lb-ft
- 3/4-16 UNF: max. 50 lb-ft

### FT 430-35 1298

**new**

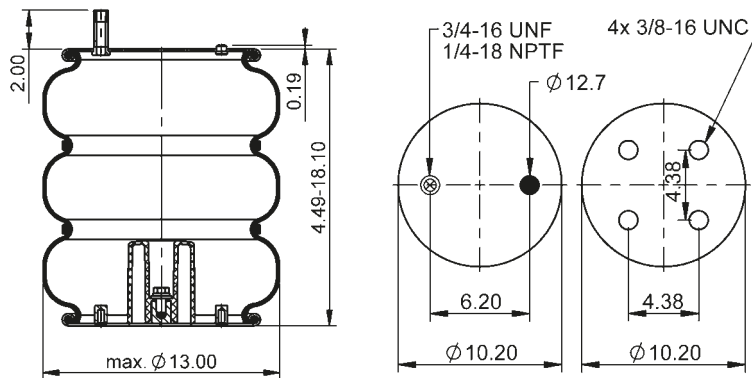

601025



16.8 lb

**Cross-reference | Cruce de Referencia**

Goodyear 3B12-337

- 1/4-18 NPTF: max. 22 lb-ft
- 3/8-16 UNC: max. 18 lb-ft
- 3/4-16 UNF: max. 50 lb-ft

### FT 430-35 1314

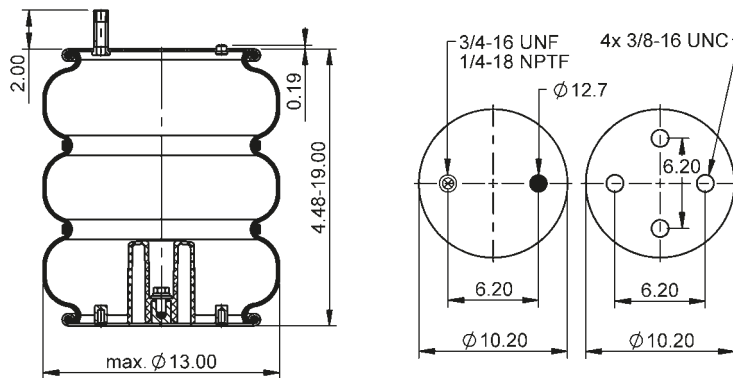

600720



16.8 lb

**Cross-reference | Cruce de Referencia**

Goodyear 3B12-339

- 1/4-18 NPTF: max. 18 lb-ft
- 3/8-16 UNC: max. 18 lb-ft
- 3/4-16 UNF: max. 50 lb-ft

### FT 530-32 325

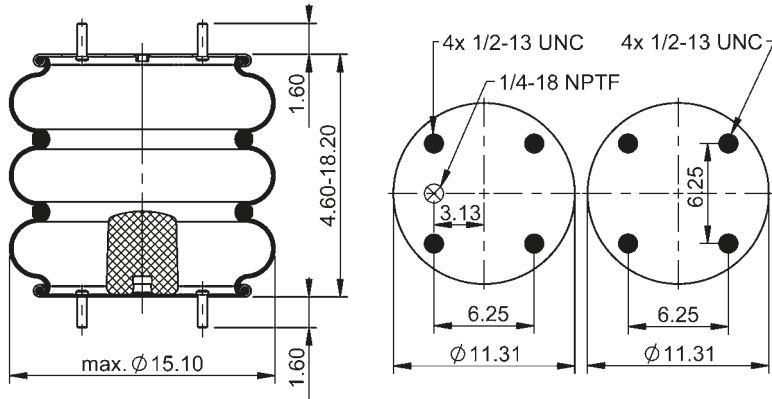

### 64503



**lb** 20.1 lb

#### Cross-reference | Cruce de Referencia

Firestone	W01-358-7818
Goodyear	3B14-359

#### Manufacturer | Fabricante

Granning	1014
Hendrickson	S-13041
Loadguard	SC2032
Navistar/Fleetrite	554803C1
Ridewell	1003587818C
SAF Holland	57007818
Silent Drive	AS-7818
Watson & Chalin	AS-0025
and more	

1/4-18 NPTF: max. 22 lb-ft  
 1/2-13 UNC: max. 35 lb-ft

### FT 530-32 329

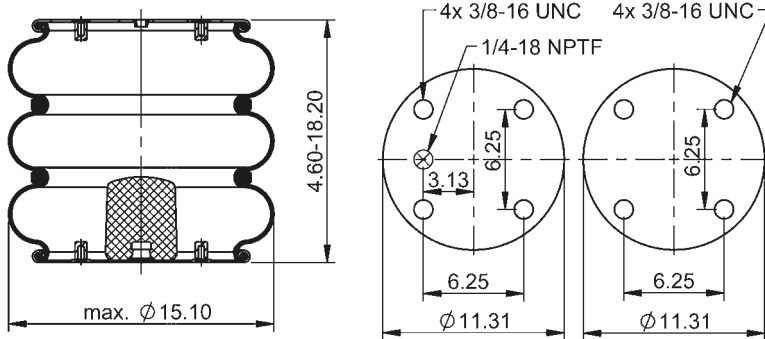

### 64504



**lb** 19.6 lb

#### Cross-reference | Cruce de Referencia

Firestone	W01-358-7798
Goodyear	3B14-356

#### Manufacturer | Fabricante

Dayton	354-7798
Granning	1613
Hendrickson	S-13039
Loadguard	SC2029
Navistar/Fleetrite	554802C1
SAF Holland	57007798
Watson & Chalin	AS-0006

1/4-18 NPTF: max. 22 lb-ft  
 3/8-16 UNC: max. 20 lb-ft

### FT 530-32 333

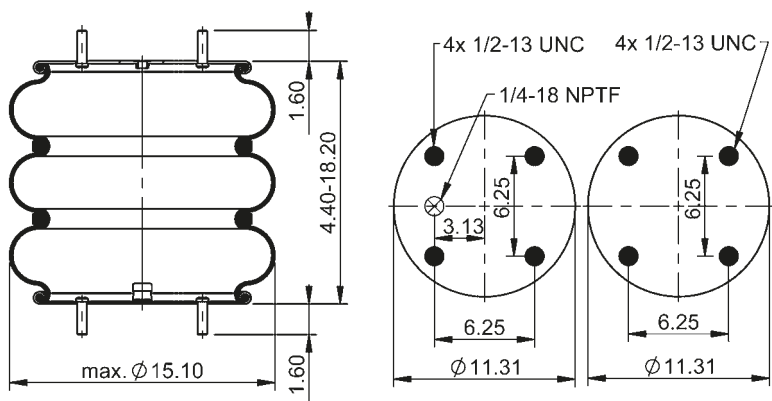

### 64505



**lb** 18.0 lb

#### Cross-reference | Cruce de Referencia

Firestone	W01-358-7800
Goodyear	3B14-360

#### Manufacturer | Fabricante

Dayton	354-7800
Granning	4514
Holland Hitch	
Loadguard	SC2030
Navistar/Fleetrite	554804C1
Ridewell	1003587800C
SAF Holland	57007800
Silent Drive	AS-7800

1/4-18 NPTF: max. 22 lb-ft  
 1/2-13 UNC: max. 35 lb-ft

### FT 530-32 336

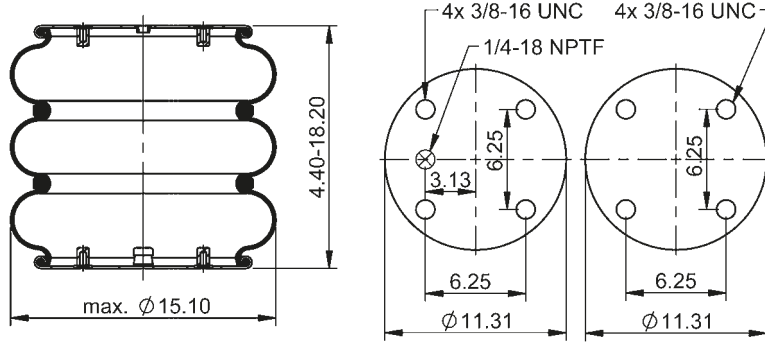

64506



18.5 lb

**Cross-reference | Cruce de Referencia**

Firestone	W01-358-7808
Goodyear	3B14-354

**Manufacturer | Fabricante**

Dayton	354-7808
EZ Ride	8030170
Hendrickson	S-13157
Loadguard	SC2031
Navistar/Fleetrite	554801C1
Peerless	0550-00030
Ridewell	1003587808C
SAF Holland	57007808
and more	

1/4-18 NPTF: max. 22 lbft  
3/8-16 UNC: max. 20 lbft

### FT 530-32 535

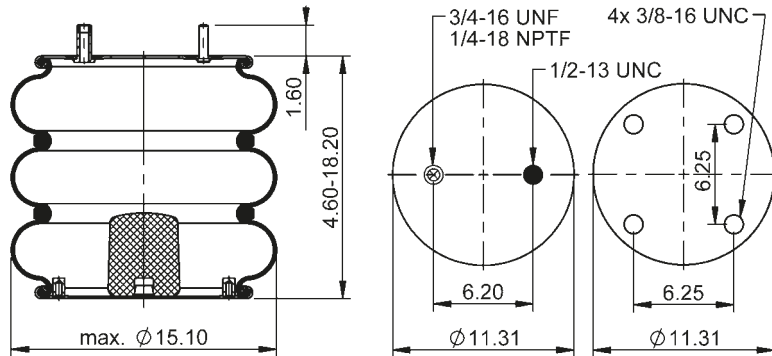

64507



19.6 lb

**Cross-reference | Cruce de Referencia**

Firestone	W01-358-7797
-----------	--------------

**Manufacturer | Fabricante**

Hendrickson	1346
Link	1103-0057

1/4-18 NPTF: max. 22 lbft  
3/8-16 UNC: max. 20 lbft  
3/4-16 UNF: max. 50 lbft

### FT 530-32 536

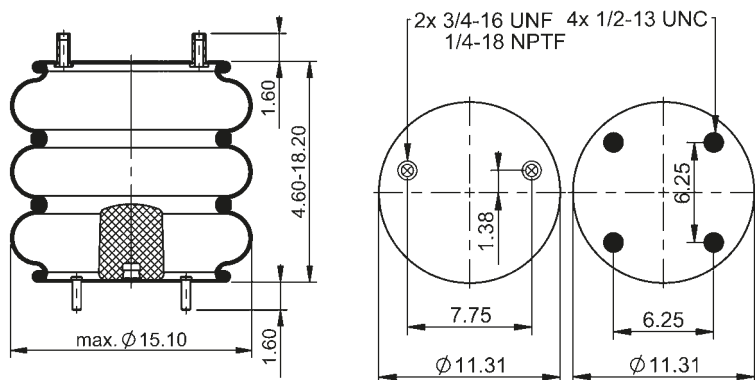

64508



20.1 lb

**Cross-reference | Cruce de Referencia**

Firestone	W01-358-7796
-----------	--------------

**Manufacturer | Fabricante**

Ridewell	1003587796C
----------	-------------

1/4-18 NPTF: max. 22 lbft  
1/2-13 UNC: max. 35 lbft  
3/4-16 UNF: max. 50 lbft

### FT 530-32 1088

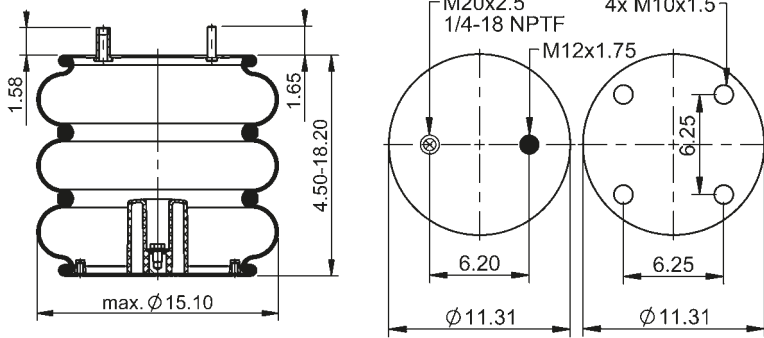

78245



**lb** 15.9 lb

**Manufacturer | Fabricante**

Hendrickson 7795

**1/4-18 NPTF:** max. 22 lb-ft  
**M10:** max. 18 lb-ft  
**M20x2.5:** max. 50 lb-ft

### FT 530-35 436

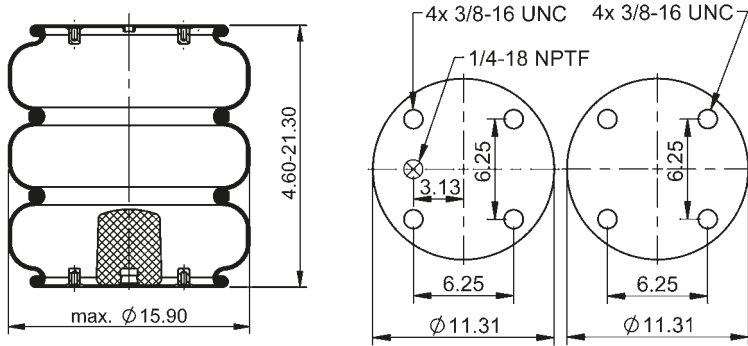

64576



**lb** 28.4 lb

**Cross-reference | Cruce de Referencia**

Firestone W01-358-7838  
 Goodyear 3B14-453

**Manufacturer | Fabricante**

Granning 1613  
 Hendrickson S-13039  
 Loadguard SC2029  
 Navistar/Fleetrite 554802C1  
 SAF Holland 57007798

**1/4-18 NPTF:** max. 22 lb-ft  
**3/8-16 UNC:** max. 20 lb-ft

### FT 530-35 437

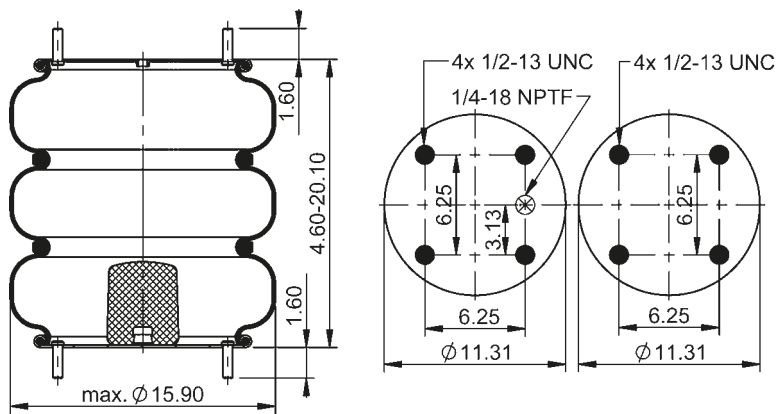

64577



**lb** 28.4 lb

**Cross-reference | Cruce de Referencia**

Firestone W01-358-7839  
 Goodyear 3B14-456

**Manufacturer | Fabricante**

Dayton 354-7839  
 Granning 1476  
 Hendrickson S-6861  
 Navistar/Fleetrite 554803C1  
 Porcupine 7818  
 Ridewell 1003587839C  
 SAF Holland 57007839  
 Watson & Chalin AS-0033  
 and more

**1/4-18 NPTF:** max. 22 lb-ft  
**1/2-13 UNC:** max. 35 lb-ft

### FT 530-35 438

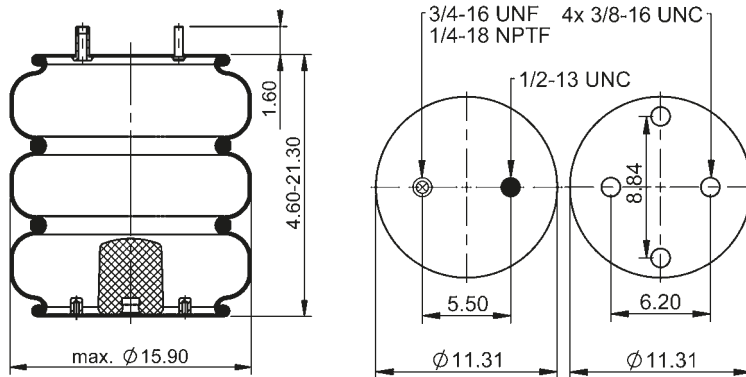

64578



**lb** 28.4 lb

**Cross-reference | Cruce de Referencia**  
Firestone W01-358-7844

**Manufacturer | Fabricante**  
Ridewell 1003587844C

1/4-18 NPTF: max. 22 lb-ft  
3/8-16 UNC: max. 20 lb-ft  
3/4-16 UNF: max. 50 lb-ft

### FT 530-35 439

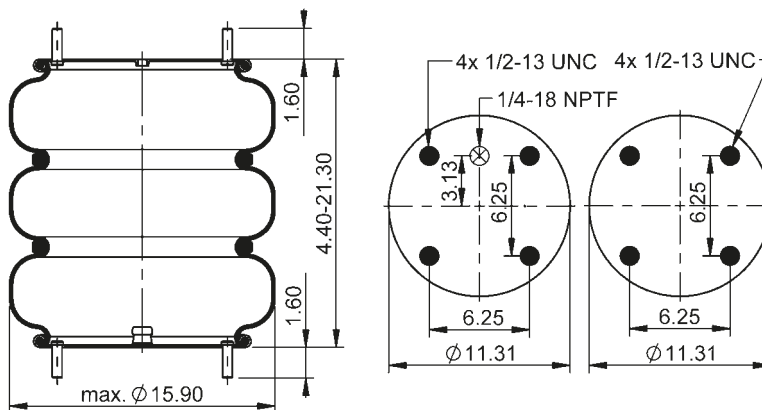

64579



**lb** 25.6 lb

**Cross-reference | Cruce de Referencia**  
Firestone W01-358-7848  
Goodyear 3B14-460

**Manufacturer | Fabricante**  
Meritor 201498  
Hendrickson S-13047  
Silent Drive AS-7848  
Suspensions, Inc. 201498

1/4-18 NPTF: max. 22 lb-ft  
1/2-13 UNC: max. 35 lb-ft

### FT 530-35 441

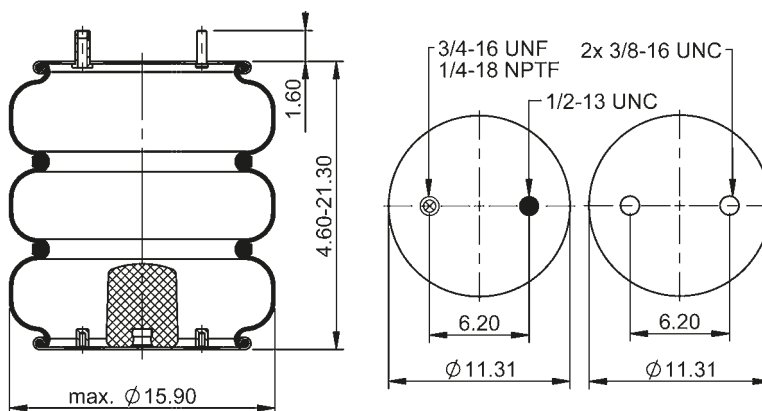

64580



**lb** 28.4 lb

**Cross-reference | Cruce de Referencia**  
Firestone W01-358-7850  
Goodyear 3B14-452

**Manufacturer | Fabricante**  
Meritor 200177  
Histeer 10301  
Link 1103-0001  
Spring Valley AS-4441  
Suspensions, Inc. 200177  
Watson & Chalin AS-0086

1/4-18 NPTF: max. 22 lb-ft  
3/8-16 UNC: max. 20 lb-ft  
3/4-16 UNF: max. 50 lb-ft

### FT 530-35 455

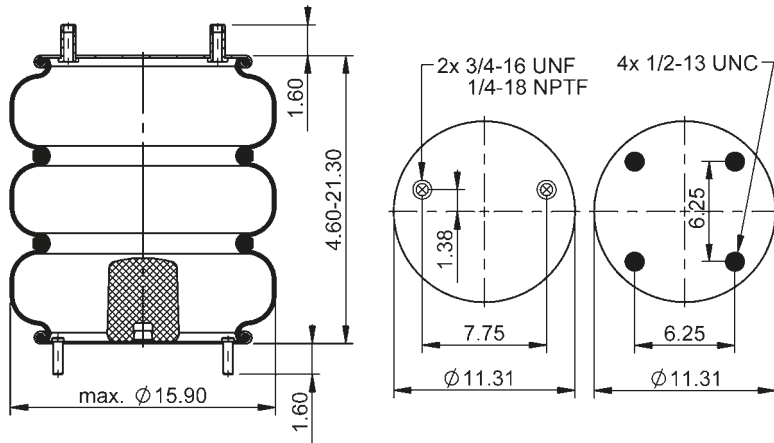

64581



**lb** 28.4 lb

**Cross-reference | Cruce de Referencia**

Firestone	W01-358-7843
Goodyear	3B14-364 3B14-457

**Manufacturer | Fabricante**

Meritor	203022
Hendrickson	S-7100
Loadguard	SC2135
Ridewell	1003587843C

1/4-18 NPTF: max. 22 lb-ft  
 1/2-13 UNC: max. 35 lb-ft  
 3/4-16 UNF: max. 50 lb-ft

### FT 530-35 456

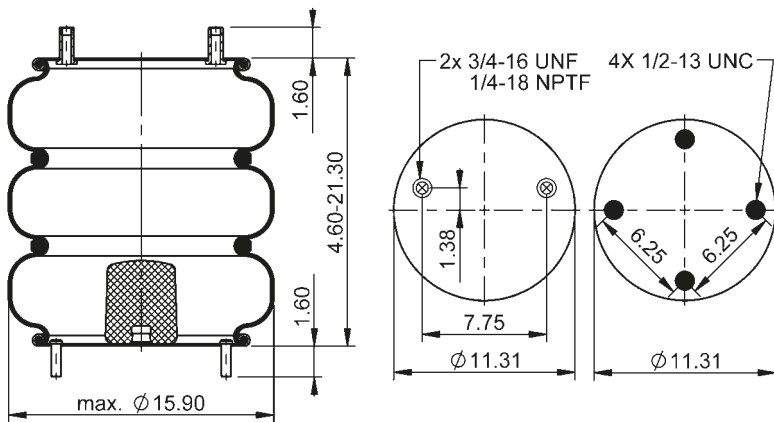

64582



**lb** 28.4 lb

**Cross-reference | Cruce de Referencia**

Firestone	W01-358-7846
Goodyear	3B14-451

**Manufacturer | Fabricante**

Dayton	354-7846
Hendrickson	S-7853
Ridewell	1003587846C

1/4-18 NPTF: max. 22 lb-ft  
 1/2-13 UNC: max. 35 lb-ft  
 3/4-16 UNF: max. 50 lb-ft

### FT 530-35 457

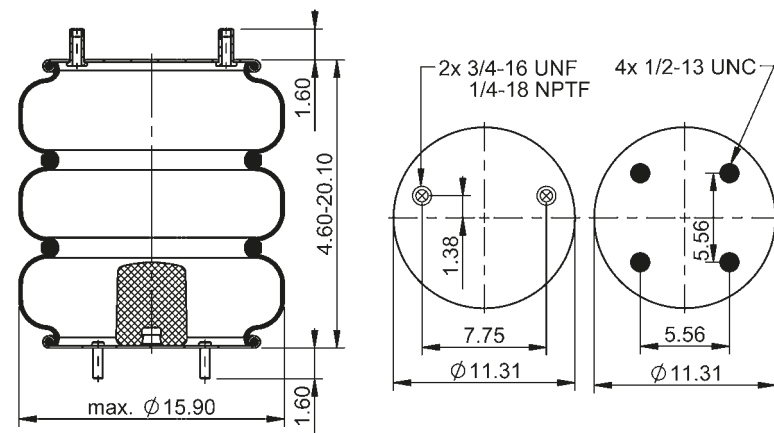

64583



**lb** 28.4 lb

**Cross-reference | Cruce de Referencia**

Firestone	W01-358-7847
Goodyear	3B14-367 3B14-459

**Manufacturer | Fabricante**

Dayton	354-7847
Hendrickson	S-8874
Loadguard	SC2136

1/4-18 NPTF: max. 22 lb-ft  
 1/2-13 UNC: max. 35 lb-ft  
 3/4-16 UNF: max. 50 lb-ft



### FT 530-35 521

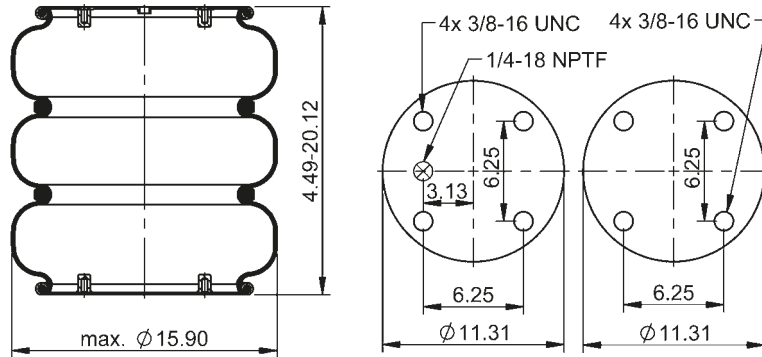

64584



**lb** 25.6 lb

**Cross-reference | Cruce de Referencia**

Firestone	W01-358-7845
Goodyear	3B14-450

1/4-18 NPTF: max. 22 lb-ft  
3/8-16 UNC: max. 20 lb-ft

### FT 530-35 522

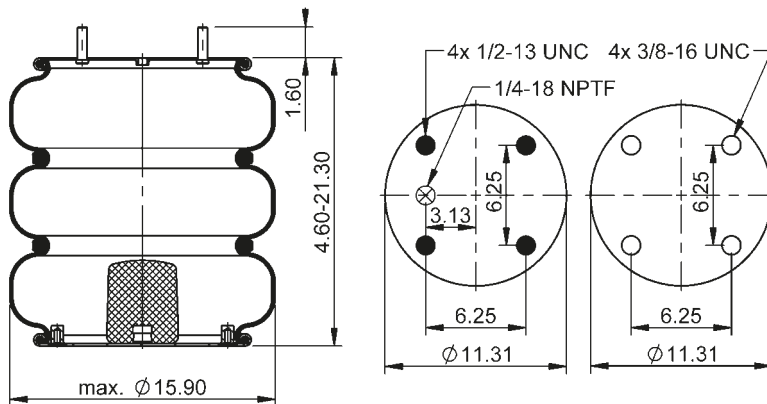

64585



**lb** 28.4 lb

**Cross-reference | Cruce de Referencia**

Firestone	W01-358-7855
Goodyear	3B14-462

**Manufacturer | Fabricante**

Granning	7026
----------	------

1/4-18 NPTF: max. 22 lb-ft  
3/8-16 UNC: max. 20 lb-ft  
1/2-13 UNC: max. 35 lb-ft

### FT 530-35 523

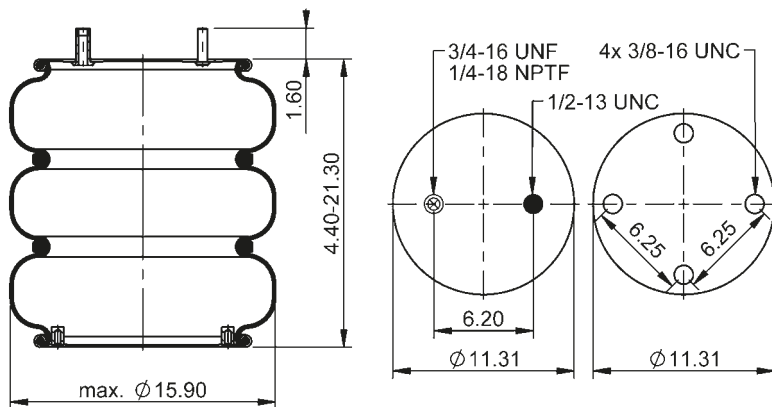

64586



**lb** 25.6 lb

**Cross-reference | Cruce de Referencia**

Firestone	W01-358-7859
Goodyear	3B14-463

**Manufacturer | Fabricante**

Hendrickson	1285
-------------	------

1/4-18 NPTF: max. 22 lb-ft  
3/8-16 UNC: max. 20 lb-ft  
3/4-16 UNF: max. 50 lb-ft

### FT 530-35 534

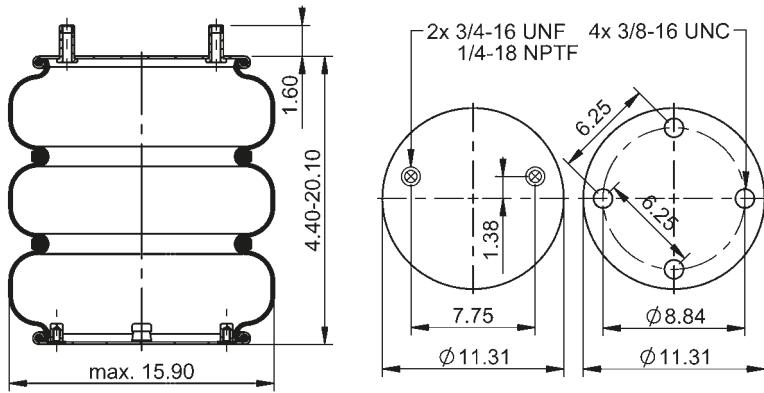

64587



**lb** 25.6 lb

**Cross-reference | Cruce de Referencia**

Firestone W01-358-7862  
Goodyear 3B14-464

**Manufacturer | Fabricante**

Hendrickson 1795

- 1/4-18 NPTF: max. 22 lb-ft
- 3/8-16 UNC: max. 20 lb-ft
- 3/4-16 UNF: max. 50 lb-ft

### FT 530-35 537

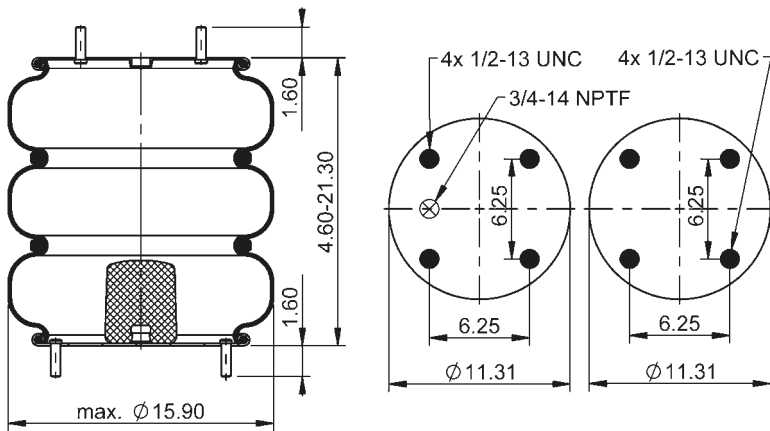

64588



**lb** 28.4 lb

**Cross-reference | Cruce de Referencia**

Firestone W01-358-7853

- 1/2-13 UNC: max. 35 lb-ft
- 3/4-14 NPTF: max. 22 lb-ft

### FT 530-35 726

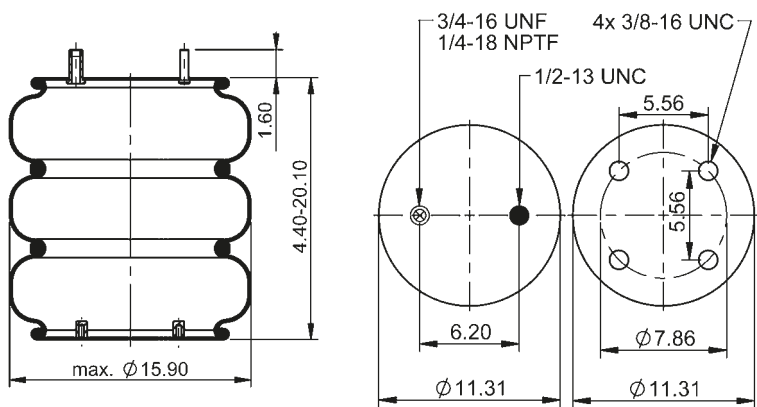

65828



**lb** 25.6 lb

**Cross-reference | Cruce de Referencia**

Firestone W01-358-7872

**Manufacturer | Fabricante**

Hendrickson 4828

- 1/4-18 NPTF: max. 22 lb-ft
- 3/8-16 UNC: max. 20 lb-ft
- 3/4-16 UNF: max. 50 lb-ft

### FT 530-35 808

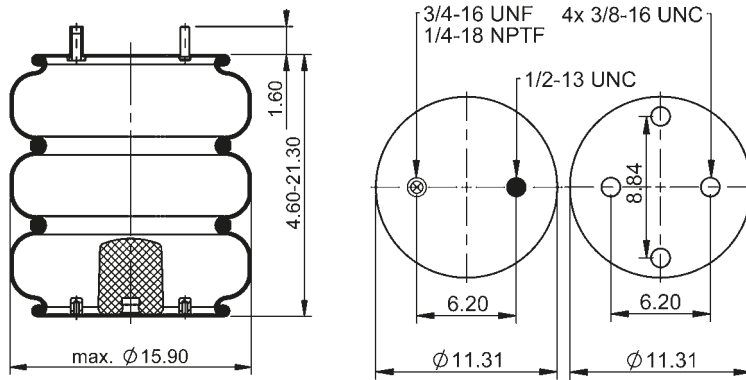

67572



**lb** 28.4 lb

**Manufacturer | Fabricante**  
Watson & Chalin AS-0222

**Wrench** 1/4-18 NPTF: max. 22 lb-ft  
3/8-16 UNC: max. 20 lb-ft  
1/2-13 UNC: max. 35 lb-ft

### FT 530-35 924

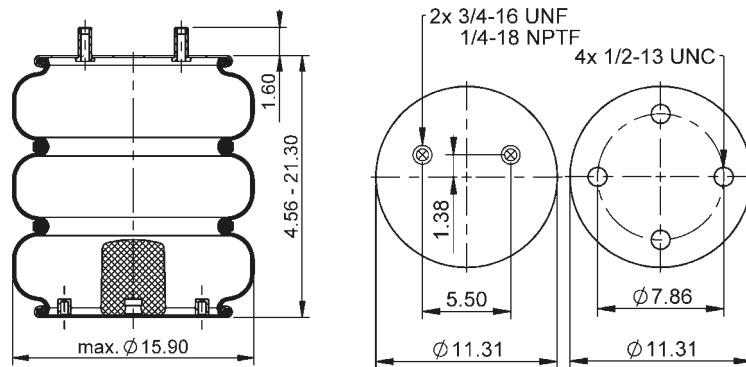

78236



**lb** 20.5 lb

**Manufacturer | Fabricante**  
SAF Holland 90557424

**Wrench** 1/4-18 NPTF: max. 22 lb-ft  
1/2-13 UNC: max. 35 lb-ft  
3/4-16 UNF: max. 50 lb-ft



# Sleeve Type Air Springs

## Bolsas de Aire para Cabina y Asientos



Sleeve Type Air Springs | Bolsas de Aire para Cabina y Asientos

### SC17-WC08

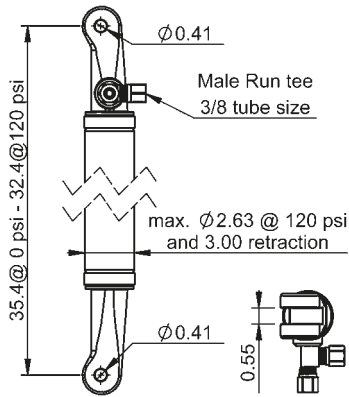

77546



**lb** 1.5 lb

**Manufacturer | Fabricante**  
 Hendrickson B-34050-2

### SC17-WC09

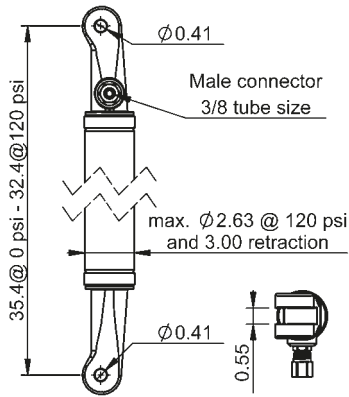

77547



**lb** 1.3 lb

**Manufacturer | Fabricante**  
 Hendrickson B-34051-2

### SC17-WC10

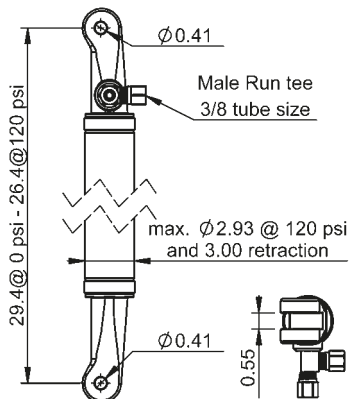

77548



**lb** 1.3 lb

**Manufacturer | Fabricante**  
 Hendrickson B-34050-1

### SC17-WC11

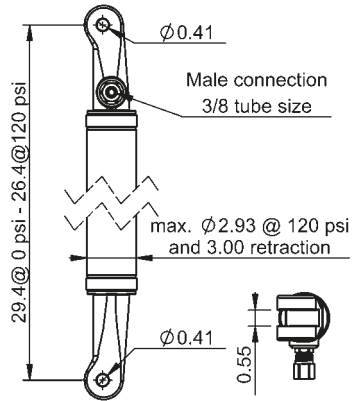

77549



0.1 lb

**Manufacturer | Fabricante**  
Hendrickson B-34051-1

### SC26-WC12

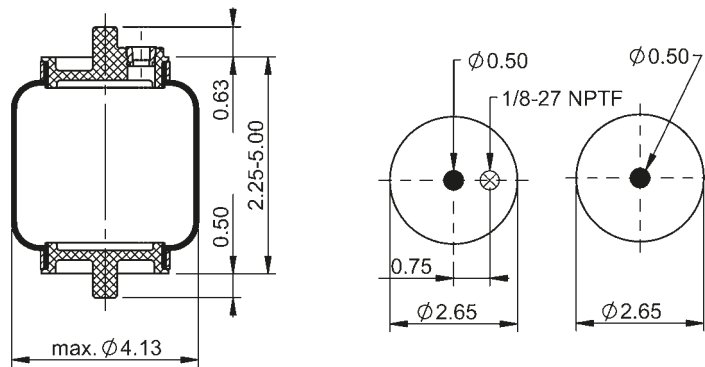

77550



0.9 lb

**Manufacturer | Fabricante**  
Hendrickson C-24488

1/8-27 NPTF: max. 1.5 lbft

### SC29-B083

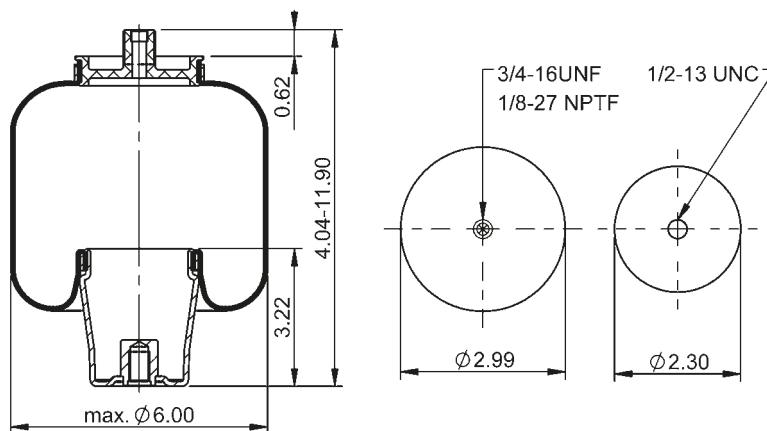

78414



2.4 lb 9313039

**Cross-reference | Cruce de Referencia**  
Firestone W02-358-7083

**Manufacturer | Fabricante**  
Link 1102-0081

1/8-27 NPTF: max. 1.5 lbft

1/2-13 UNC: max. 18 lbft

3/4-16 UNF: max. 9 lbft

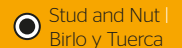
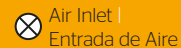
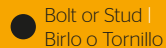

### SC29-B092

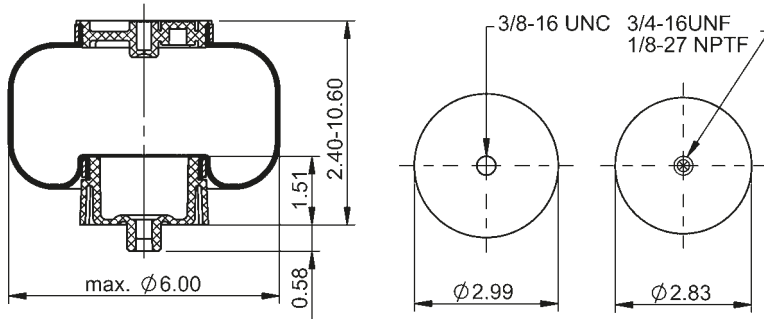

67854



**lb** 0.7 lb **No.** 9309740

**Cross-reference | Cruce de Referencia**  
 Firestone W02-358-7092

**Manufacturer | Fabricante**  
 Kenworth KWCSA  
 Link 1102-0083  
 1102-K083  
 T811001

1/8-27 NPTF: max. 1.5 lb-ft  
 3/8-16 UNC: max. 3.5 lb-ft  
 3/4-16 UNC: max. 9 lb-ft

### SC29-B093

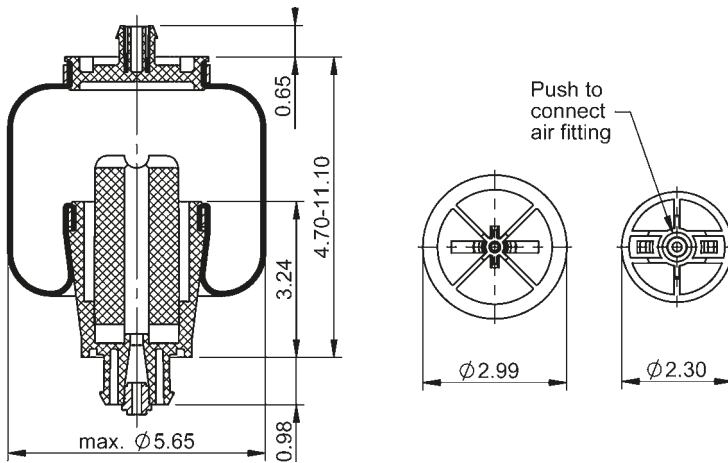

75313



**lb** 1.3 lb **No.** 9317016

**Cross-reference | Cruce de Referencia**  
 Firestone W02-358-7093  
 Goodyear 1S5-190

**Manufacturer | Fabricante**  
 Peterbilt 29-06016

### SC29-B110

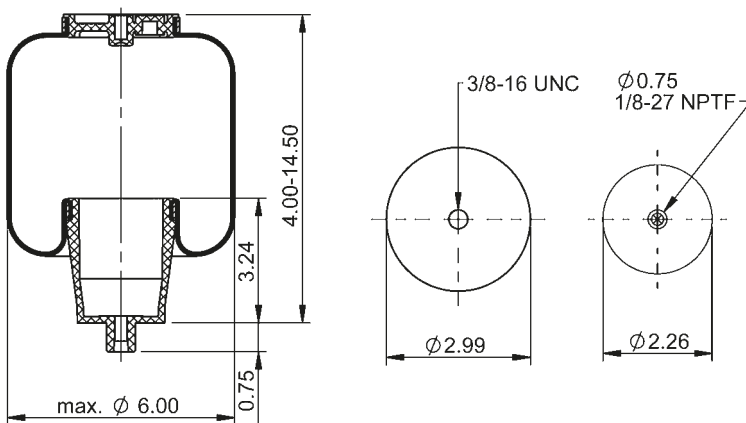

69437



**lb** 2.2 lb **No.** 9314226

**Cross-reference | Cruce de Referencia**  
 Firestone W02-358-7110  
 Goodyear 1S5-152

**Manufacturer | Fabricante**  
 Kenworth T2000  
 Link 1102-0082  
 1102-K082  
 R81-1002

1/8-27 NPTF: max. 1.5 lb-ft  
 3/8-16 UNC: max. 3.5 lb-ft



### SC29-B152

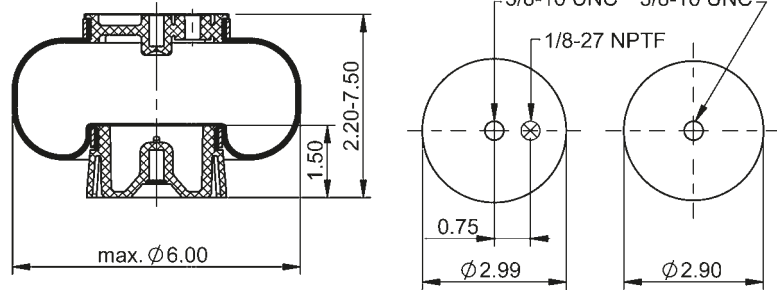

67862



**lb** 0.7 lb **No.** 9310094

**Cross-reference | Cruce de Referencia**  
Firestone W02-358-7152

**Manufacturer | Fabricante**  
Knoedler 100095-000

1/8-27 NPTF: max. 1.5 lb-ft  
3/8-16 UNC: max. 3.5 lb-ft

### SC29-B200

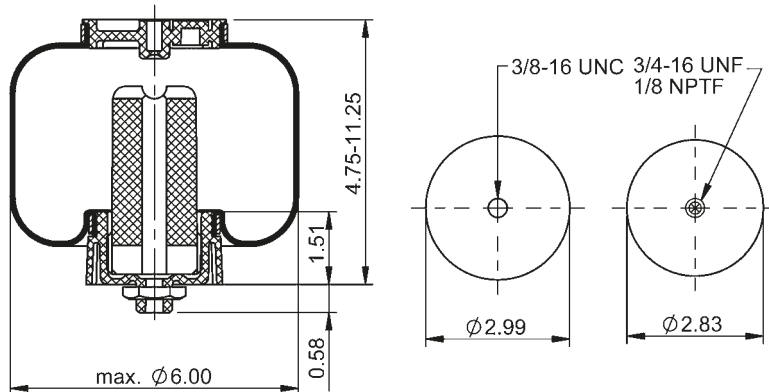

67767



**lb** 0.8 lb **No.** 9309740

**Cross-reference | Cruce de Referencia**  
Firestone W02-358-7200

**Manufacturer | Fabricante**  
Ford F6HT5CO63BA  
Freightliner 18-42609-000

1/8-27 NPTF: max. 1.5 lb-ft  
3/8-16 UNC: max. 3.5 lb-ft  
3/4-16 UNC: max. 9 lb-ft

### SC29-BG07

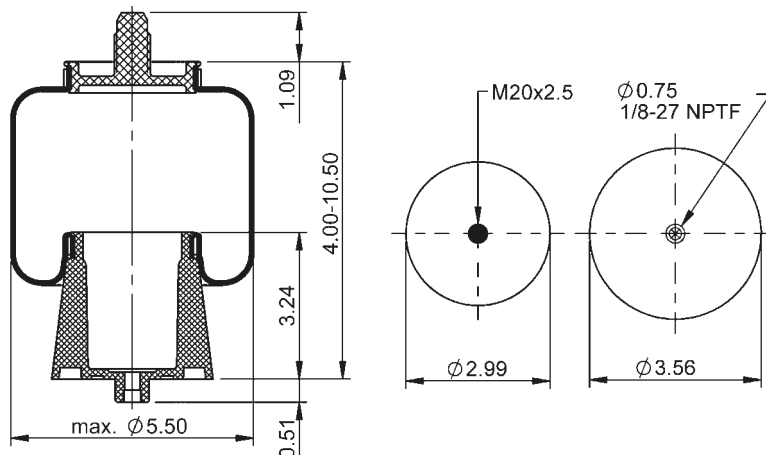

78405



**lb** 3.0 lb **No.** 9318812

**Cross-reference | Cruce de Referencia**  
Goodyear 1S5-154

**Manufacturer | Fabricante**  
Mack 227QS312BM

1/8-27 NPTF: max. 1.5 lb-ft  
M20x2.5: max. 9 lb-ft

### SC29-BG08

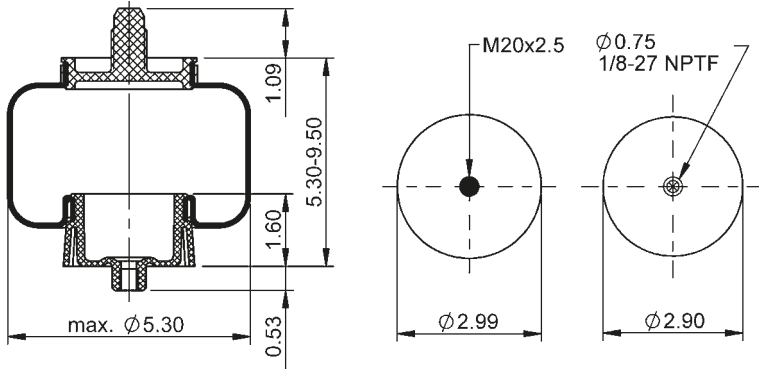

78417



**lb** 2.6 lb

**Cross-reference | Cruce de Referencia**

Goodyear 1S5-164

**Manufacturer | Fabricante**

Mack 227QS47M

1/8-27 NPTF: max. 1.5 lbft  
M20x2.5: max. 9 lbft

### SC29-0001

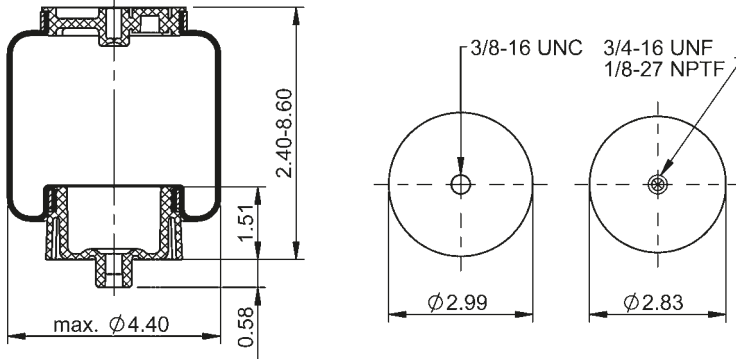

67770



**lb** 0.7 lb **No.** 9309740

**Cross-reference | Cruce de Referencia**

Firestone W02-358-7001  
W02-358-7002  
W02-358-7031

**Manufacturer | Fabricante**

Flxible 97-9999-01867  
Link 1102-0023  
1102-K023  
R811001  
Mack 227QS33  
National Seating 2123403

1/8-27 NPTF: max. 1.5 lbft  
3/8-16 UNC: max. 3.5 lbft  
3/4-16 UNF: max. 9 lbft

### SC29-0040

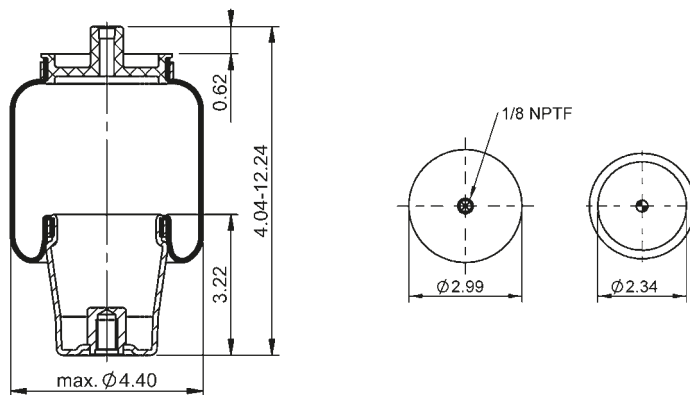

70019



**lb** 4.0 lb **No.** 9313039

**Cross-reference | Cruce de Referencia**

Firestone W02-358-7040

**Manufacturer | Fabricante**

Knoedler 7010  
Sears S5388  
Seats 707338

1/8-27 NPTF: max. 1.5 lbft  
1/2-13 UNC: max. 25 lbft  
3/4-16 UNF: max. 9 lbft

### SC29-0041

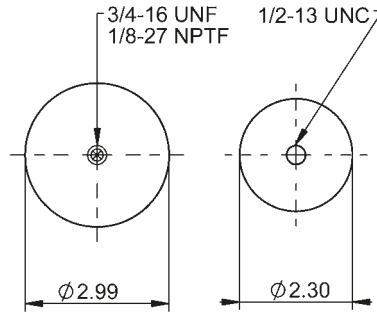
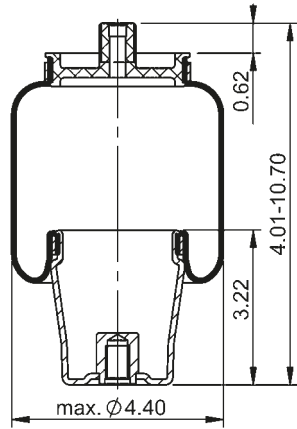

69417



**lb** 2.3 lb **No.** 9313039

**Cross-reference | Cruce de Referencia**  
 Firestone W02-358-7041  
 W02-811-7041

**Manufacturer | Fabricante**  
 Sears S8645

1/8-27 NPTF: max. 1.5 lbft  
 1/2-13 UNC: max. 25 lbft  
 3/4-16 UNF: max. 9 lbft

### SC29-0049

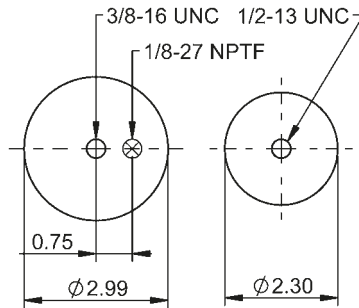
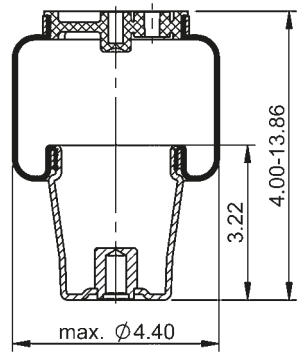

69925



**lb** 1.5 lb **No.** 9313039

**Cross-reference | Cruce de Referencia**  
 Firestone W02-358-7049

**Manufacturer | Fabricante**  
 3-T's W02-T03-7049

1/8-27 NPTF: max. 1.5 lbft  
 3/8-16 UNC: max. 3.5 lbft  
 1/2-13 UNC: max. 10 lbft

### SC29-0054

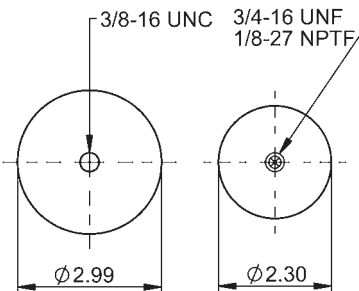
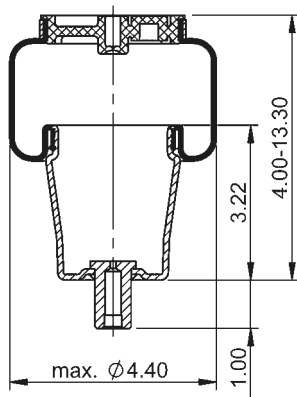

69923



**lb** 1.5 lb **No.** 9313596

**Cross-reference | Cruce de Referencia**  
 Firestone W02-358-7054

1/8-27 NPTF: max. 1.5 lbft  
 3/8-16 UNC: max. 3.5 lbft  
 3/4-16 UNF: max. 9 lbft

### SC29-0055

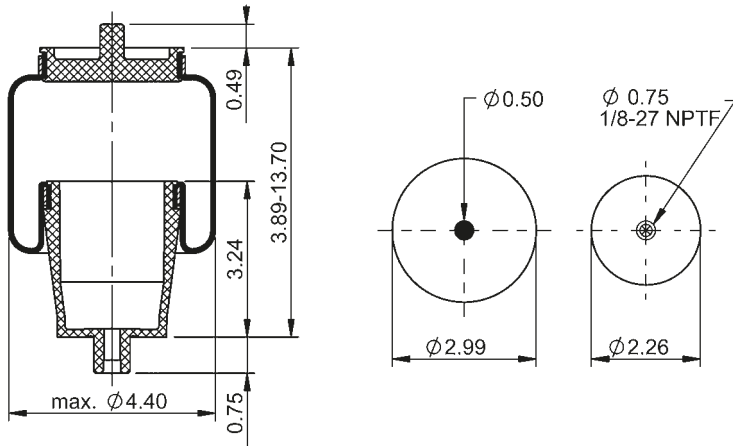

69926



**lb** 1.5 lb **No.** 9314226

**Cross-reference | Cruce de Referencia**  
 Firestone W02-358-7003  
 W02-358-7050 (Plastic)  
 W02-358-7055  
 Goodyear 1S4-035

**Manufacturer | Fabricante**  
 National Seating 2112283

1/8-27 NPTF: max. 1.5 lbft

### SC29-0073

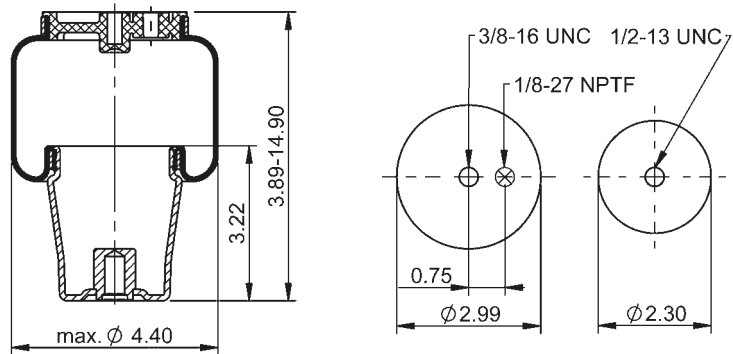

69927



**lb** 1.5 lb **No.** 9313039

**Cross-reference | Cruce de Referencia**  
 Firestone W02-358-7073

1/8-27 NPTF: max. 1.5 lbft

3/8-16 UNC: max. 3.5 lbft

1/2-13 UNC: max. 10 lbft

### SC29-0076

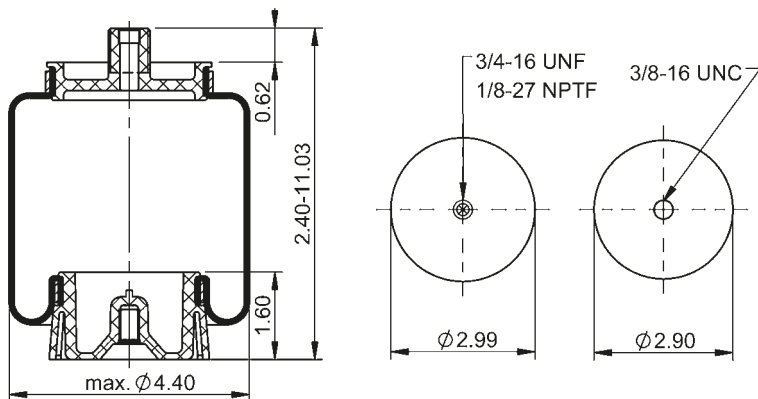

78411



**lb** 0.9 lb **No.** 9310094

**Cross-reference | Cruce de Referencia**  
 Firestone W02-358-7076

1/8-27 NPTF: max. 1.5 lbft

3/8-16 UNC: max. 3.5 lbft

3/4-16 UNF: max. 9 lbft

### SC29-0086

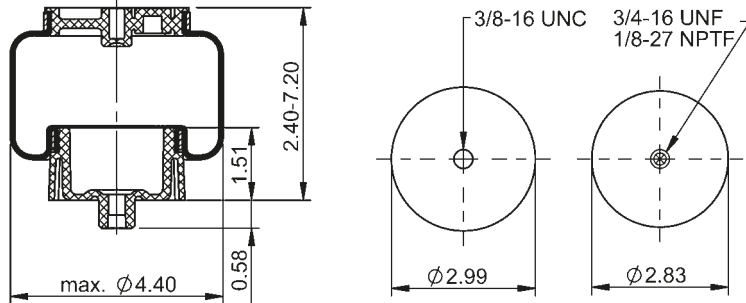

67858



**lb** 0.7 lb **No.** 9309740

**Cross-reference | Cruce de Referencia**

Firestone W02-358-7086  
Goodyear 1S4-058

**Manufacturer | Fabricante**

Link 1102-0025

1/8-27 NPTF: max. 1.5 lbft  
3/8-16 UNC: max. 3.5 lbft  
3/4-16 UNF: max. 9 lbft

### SC29-0098

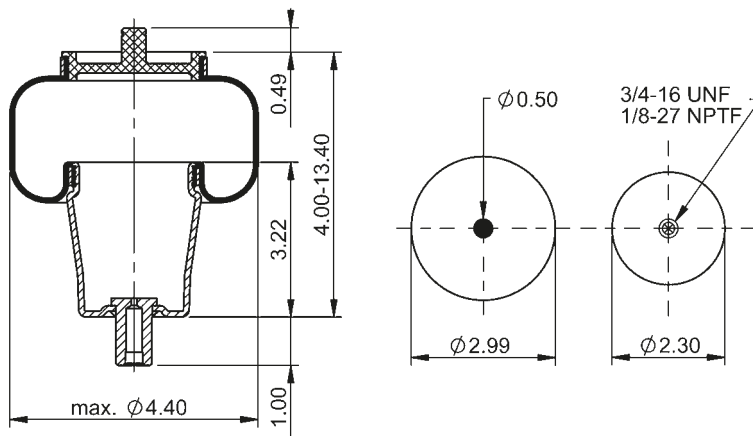

69924



**lb** 1.5 lb **No.** 9313596

**Cross-reference | Cruce de Referencia**

Firestone W02-358-7098

**Manufacturer | Fabricante**

Link 1102-0027

1/8-27 NPTF: max. 1.5 lbft  
3/4-16 UNF: max. 9 lbft

### SC29-0100

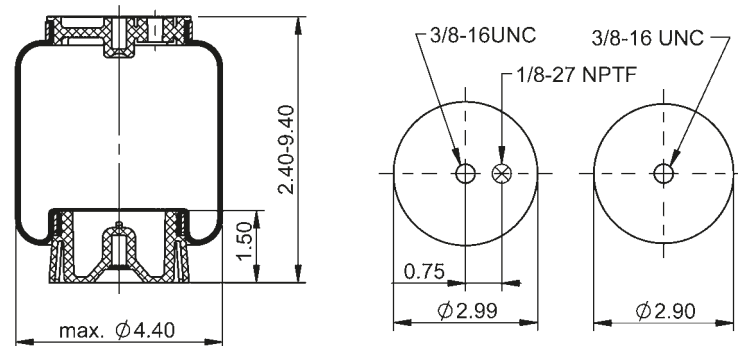

67637



**lb** 0.7 lb **No.** 9310094

**Cross-reference | Cruce de Referencia**

Firestone W02-358-7100

**Manufacturer | Fabricante**

3-T's W02-T03-7100

1/8-27 NPTF: max. 1.5 lbft  
3/8-16 UNC: max. 3.5 lbft

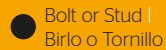

Bolt or Stud | Birlo o Tornillo



Hole | Tuerca Ciega



Combination Stud | Combinación de Entrada de Aire y Birlo



Air Inlet | Entrada de Aire



Stud and Nut | Birlo y Tuerca

### SC29-O132

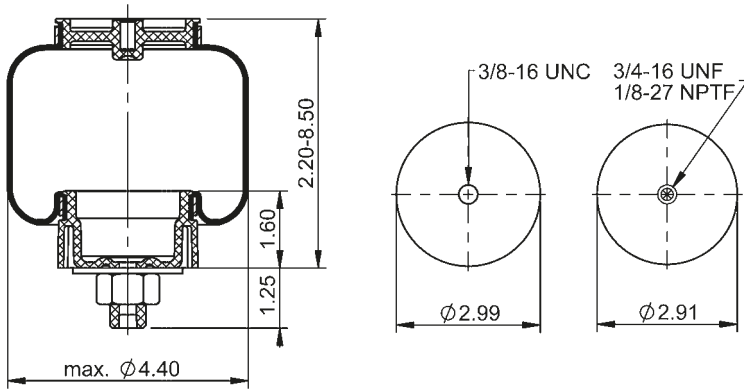

### 75315



**lb** 0.9 lb **No.** 9317132

#### Cross-reference | Cruce de Referencia

Firestone	W02-358-7132
Goodyear	1S4-234

#### Manufacturer | Fabricante

Peterbilt	R81-6003
-----------	----------

1/8-27 NPTF: max. 1.5 lb-ft  
 3/8-16 UNC: max. 3.5 lb-ft  
 3/4-16 UNF: max. 9 lb-ft

### SC29-O150

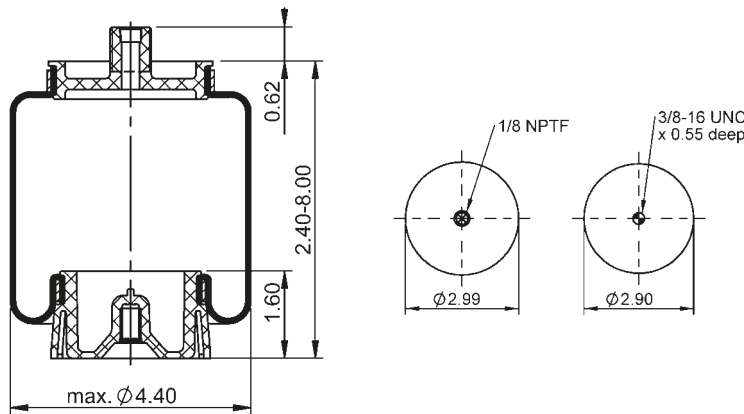

### 70021



**lb** 0.8 lb **No.** 9310094

#### Cross-reference | Cruce de Referencia

Firestone	W02-358-7150
	W02-811-7150

#### Manufacturer | Fabricante

Sears	S13384
-------	--------

1/8-27 NPTF: max. 1.5 lb-ft  
 3/8-16 UNC: max. 3.5 lb-ft  
 3/4-16 UNF: max. 9 lb-ft

### SC29-O155

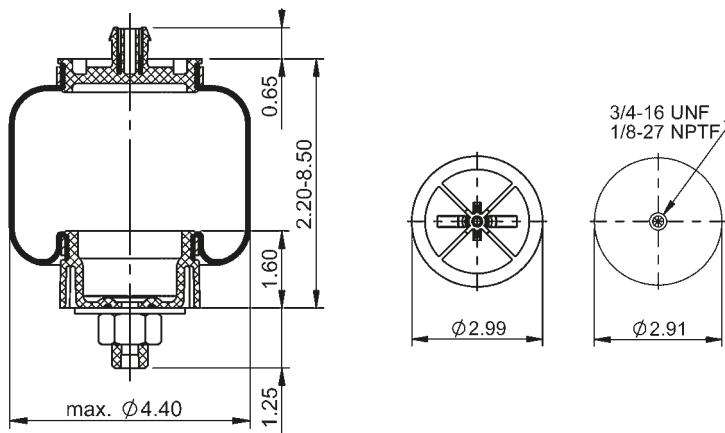

### 75314



**lb** 0.9 lb **No.** 9317132

#### Cross-reference | Cruce de Referencia

Firestone	W02-358-7155
-----------	--------------

#### Manufacturer | Fabricante

DYNA CRAFT	D5000-2253
Kenworth	R81-6002
Peterbilt	20-19036

1/8-27 NPTF: max. 1.5 lb-ft  
 3/4-16 UNF: max. 9 lb-ft

### SC29-O201

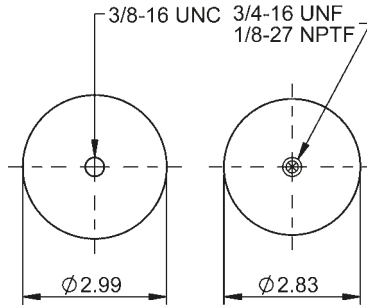
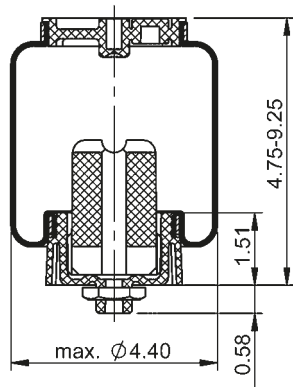

67766



**lb** 1.0 lb **No.** 9309740

**Cross-reference | Cruce de Referencia**  
 Firestone W02-358-7201

**Manufacturer | Fabricante**  
 Ford F6HT5C06CAB  
 Freightliner 18-45068-000

1/8-27 NPTF: max. 1.5 lbft  
 3/8-16 UNC: max. 3.5 lbft  
 3/4-16 UNF: max. 9 lbft

### SC29-OG05

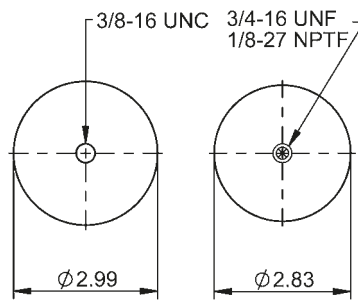
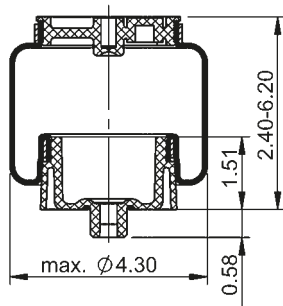

73607



**lb** 1.5 lb **No.** 9309740

**Cross-reference | Cruce de Referencia**  
 Goodyear 1S4-007

1/8-27 NPTF: max. 1.5 lbft  
 3/8-16 UNC: max. 3.5 lbft  
 3/4-16 UNF: max. 9 lbft

### SC29-OG13

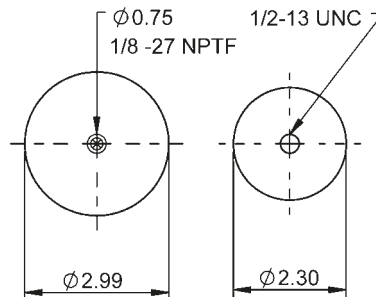
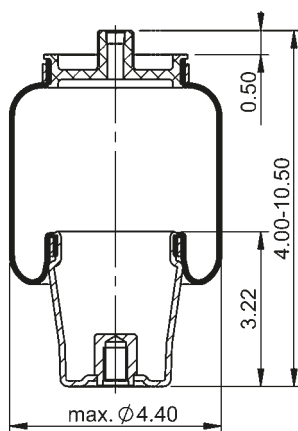

78379



**lb** 2.3 lb **No.** 9313039

**Cross-reference | Cruce de Referencia**  
 Goodyear 1S4-044

**Manufacturer | Fabricante**  
 Link 1101-0023

1/8-27 NPTF: max. 1.5 lbft  
 1/2-13 UNC: max. 10 lbft

### SC29-P116

**new**

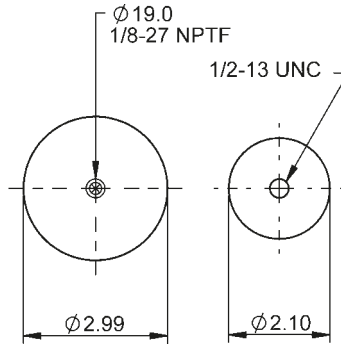
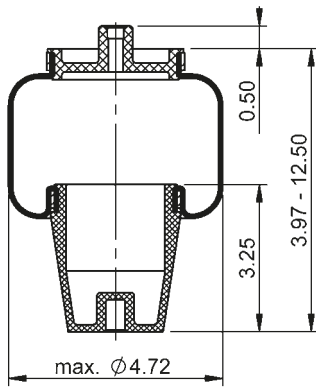

### 601575



**lb** 1.0 lb **No.** 9318895

**Cross-reference | Cruce de Referencia**  
Firestone W02-358-7116

**Manufacturer | Fabricante**  
Link 1101-0030

**1/8-27 NPTF:** max. 1.5 lbft  
**1/2-13 UNC:** max. 6 lbft

### SC29-PG09

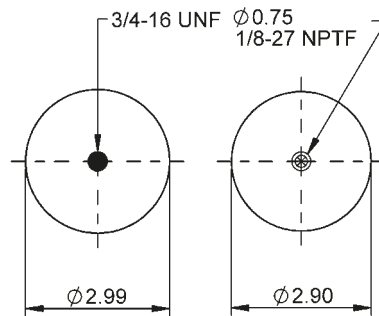
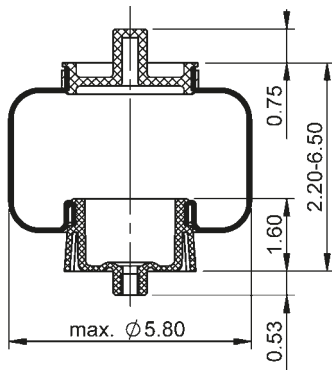

### 78418



**lb** 2.6 lb

**Cross-reference | Cruce de Referencia**  
Goodyear 1S4-173

**1/8-27 NPTF:** max. 1.5 lbft  
**3/4-16 UNF:** max. 9 lbft

### SC29-R007

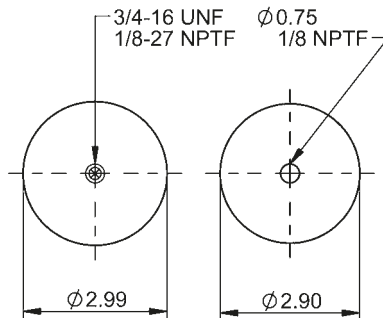
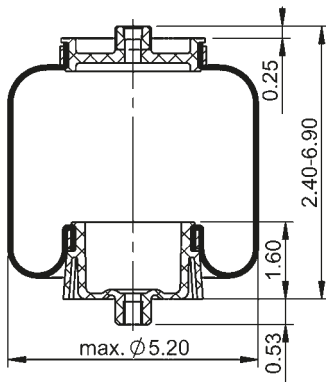

### 70014



**lb** 0.8 lb **No.** 9312279

**Cross-reference | Cruce de Referencia**  
Firestone W02-358-7007  
Goodyear 1S4-067

**Manufacturer | Fabricante**  
Mack 227QS34

**1/8-27 NPTF:** max. 1.5 lbft  
**3/4-16 UNF:** max. 9 lbft

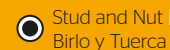
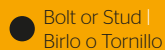



### SC29-R080

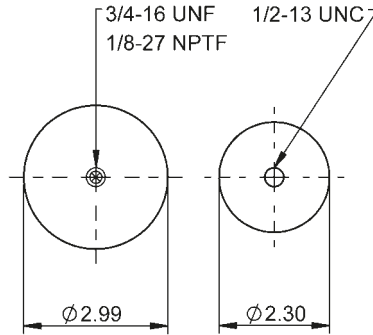
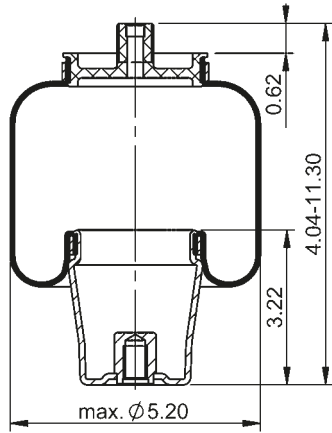

78412



**lb** 2.4 lb

**Cross-reference | Cruce de Referencia**

Firestone	W02-358-7080
Goodyear	1S4.5-107

**Manufacturer | Fabricante**

Link	1102-0031
------	-----------



1/8-27 NPTF: max. 1.5 lbft

1/2-13 UNC: max. 18 lbft

3/4-16 UNF: max. 9 lbft

### SC29-W032

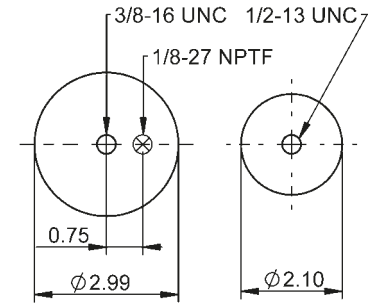
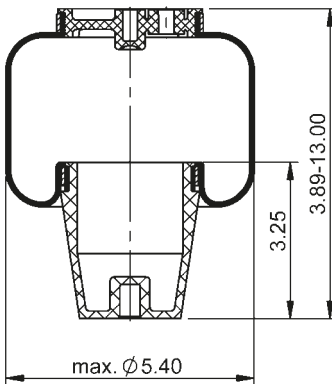

69928



**lb** 1.5 lb **No.** 9313039

**Cross-reference | Cruce de Referencia**

Firestone	W02-358-7032
-----------	--------------



1/8-27 NPTF: max. 1.5 lbft

3/8-16 UNC: max. 3.5 lbft

1/2-13 UNC: max. 10 lbft

### SC29-W035

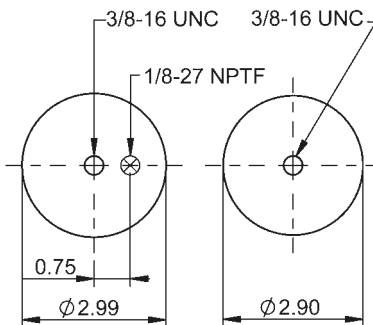
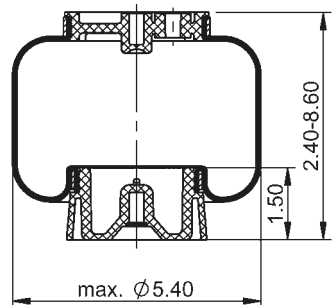

67851



**lb** 0.7 lb **No.** 9310094

**Cross-reference | Cruce de Referencia**

Firestone	W02-358-7035
Goodyear	1S4.5-121

**Manufacturer | Fabricante**

Link	1102-0046
Mack	227QS33
Sears	S-20235
	S-9383



1/8-27 NPTF: max. 1.5 lbft

3/8-16 UNC: max. 3.5 lbft



Bolt or Stud | Birlo o Tornillo



Hole | Tuerca Ciega



Combination Stud | Combinación de Entrada de Aire y Birlo



Air Inlet | Entrada de Aire



Stud and Nut | Birlo y Tuerca

### SC29-W037

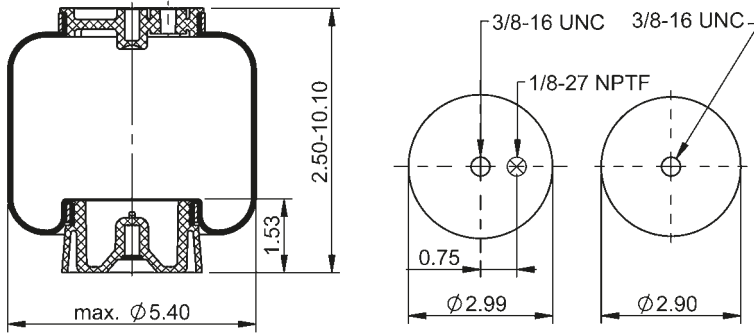

70017



**lb** 1.3 lb **No.** 9310094

**Cross-reference | Cruce de Referencia**  
Firestone W02-358-7037

**Manufacturer | Fabricante**  
Air Flex W02-A05-7037

1/8-27 NPTF: max. 1.5 lb-ft  
3/8-16 UNC: max. 3.5 lb-ft

### SC29-W042

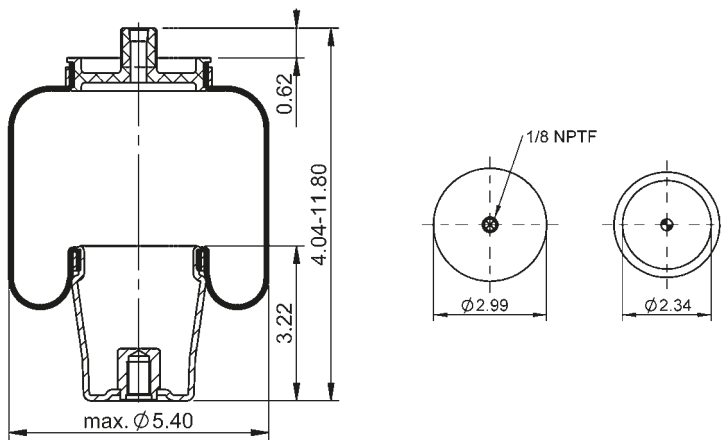

70020



**lb** 2.4 lb **No.** 9313039

**Cross-reference | Cruce de Referencia**  
Firestone W02-358-7042

**Manufacturer | Fabricante**  
Link 1102-0041

1/8-27 NPTF: max. 1.5 lb-ft  
1/2-13 UNC: max. 18 lb-ft  
3/4-16 UNF: max. 9 lb-ft

### SC29-W045

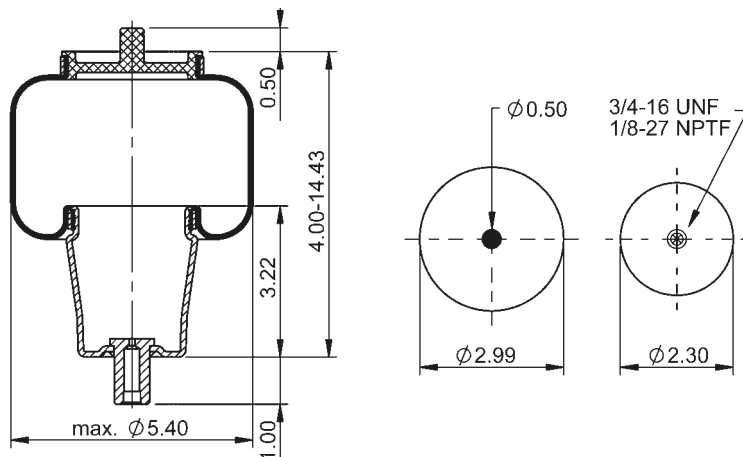

69929



**lb** 1.8 lb **No.** 9313596

**Cross-reference | Cruce de Referencia**  
Firestone W02-358-7045

**Manufacturer | Fabricante**  
Link 1102-0042

1/8-27 NPTF: max. 1.5 lb-ft  
3/4-16 UNF: max. 9 lb-ft

### SC29-W056

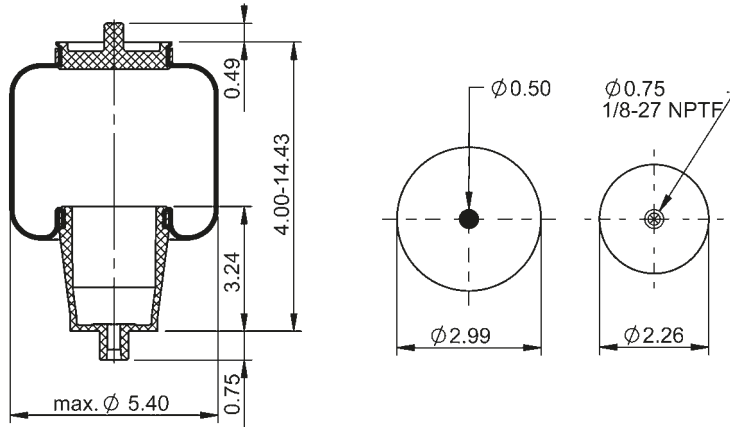

69930



**lb** 1.8 lb **No.** 9314226

**Cross-reference | Cruce de Referencia**

Firestone W02-358-7056  
Goodyear 1S4.5-113

**Manufacturer | Fabricante**

Link 1102-0043

1/8-27 NPTF: max. 1.5 lbft

### SC29-W061

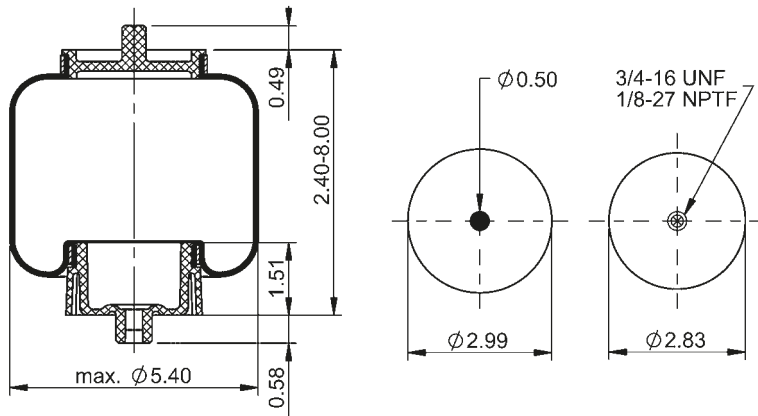

67861



**lb** 0.7 lb **No.** 9309740

**Cross-reference | Cruce de Referencia**

Firestone W02-358-7061

1/8-27 NPTF: max. 1.5 lbft

3/4-16 UNF: max. 9 lbft

### SC29-W067

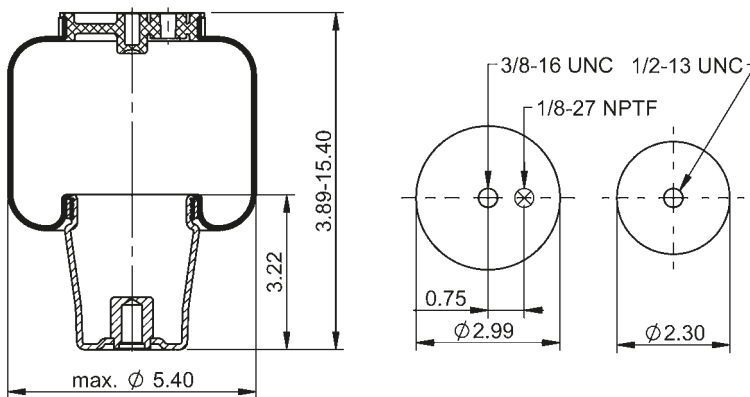

69931



**lb** 1.5 lb **No.** 9313039

**Cross-reference | Cruce de Referencia**

Firestone W02-358-7067

**Manufacturer | Fabricante**

Air Flex W02-A05-7067

1/8-27 NPTF: max. 1.5 lbft

3/8-16 UNC: max. 3.5 lbft

1/2-13 UNC: max. 10 lbft

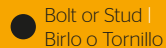

Bolt or Stud | Birlo o Tornillo



Hole | Tuerca Ciega



Combination Stud | Combinación de Entrada de Aire y Birlo



Air Inlet | Entrada de Aire



Stud and Nut | Birlo y Tuerca

### SC29-W074

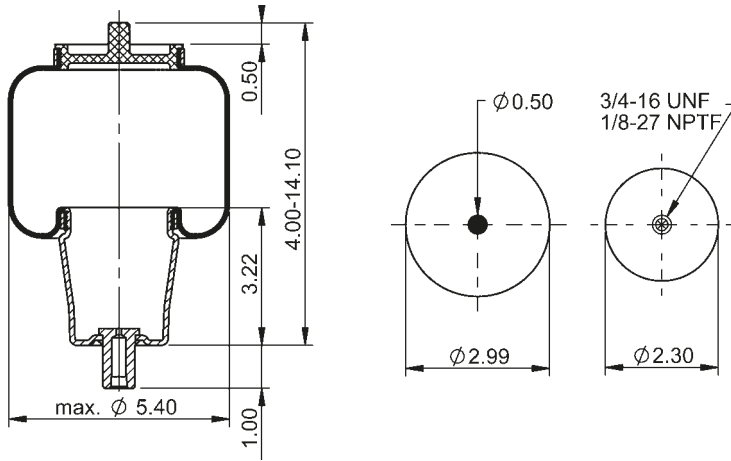

69416



**lb** 1.5 lb **No.** 9313596

**Cross-reference | Cruce de Referencia**  
Firestone W02-358-7074

**Manufacturer | Fabricante**  
Link 1102-0045  
1102-0047

1/8-27 NPTF: max. 1.5 lb-ft  
3/4-16 UNF: max. 9 lb-ft

### SC29-W075

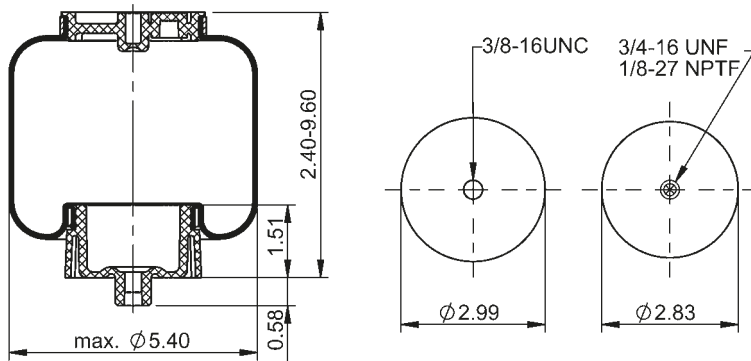

67859



**lb** 0.7 lb **No.** 9309740

**Cross-reference | Cruce de Referencia**  
Firestone W02-358-7075

**Manufacturer | Fabricante**  
Link 1102-0048

1/8-27 NPTF: max. 1.5 lb-ft  
3/8-16 UNC: max. 3.5 lb-ft  
3/4-16 UNF: max. 9 lb-ft

### SC29-W087

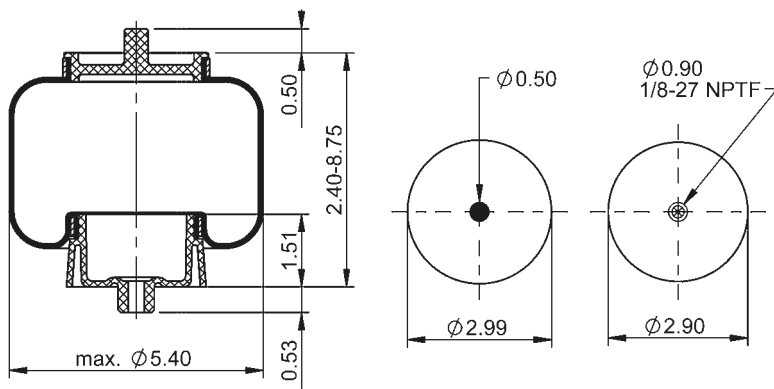

67636



**lb** 0.7 lb **No.** 9312279

**Cross-reference | Cruce de Referencia**  
Firestone W02-358-7087  
Goodyear 1S5-040

**Manufacturer | Fabricante**  
Freightliner GYR 1S5-040

1/8-27 NPTF: max. 1.5 lb-ft

### SC29-W103

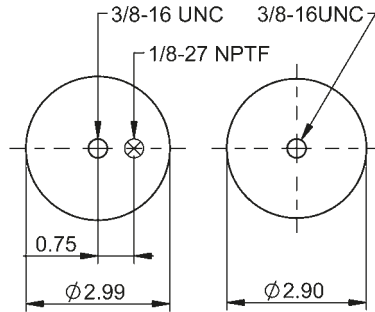
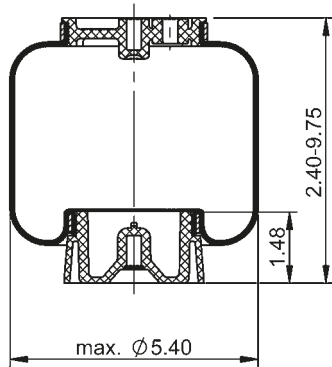

67860



**lb** 0.7 lb **No.** 9310094

**Cross-reference | Cruce de Referencia**  
Firestone W02-358-7103

**Manufacturer | Fabricante**  
3-T's W02-T03-7103

1/8-27 NPTF: max. 1.5 lbft  
3/8-16 UNC: max. 3.5 lbft

### SC29-Y036

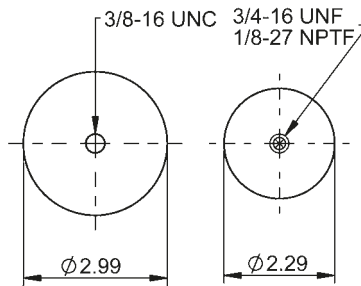
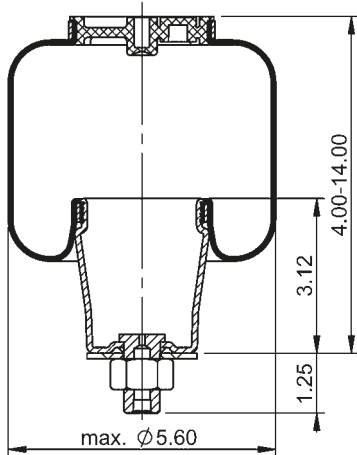

68162



**lb** 1.8 lb **No.** 9313363

**Cross-reference | Cruce de Referencia**  
Firestone W02-358-7036  
Goodyear 155-186

**Manufacturer | Fabricante**  
Peterbilt 29-02454  
29-03200

1/8-27 NPTF: max. 1.5 lbft  
3/8-16 UNC: max. 3.5 lbft  
3/4-16 UNF: max. 9 lbft

### SC29-Y043

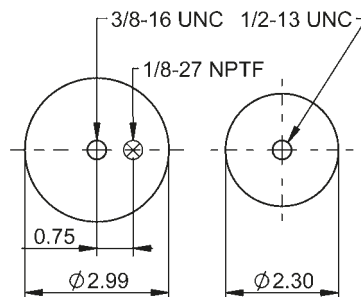
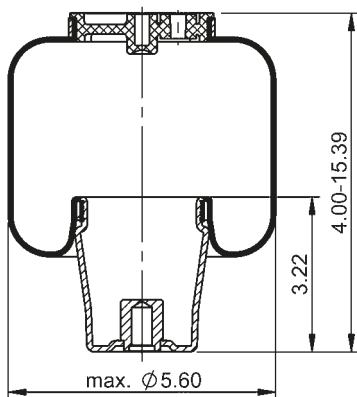

69932



**lb** 1.5 lb **No.** 9313039

**Cross-reference | Cruce de Referencia**  
Firestone W02-358-7043

1/8-27 NPTF: max. 1.5 lbft  
3/8-16 UNC: max. 3.5 lbft  
1/2-13 UNC: max. 10 lbft

### SC29-Y044

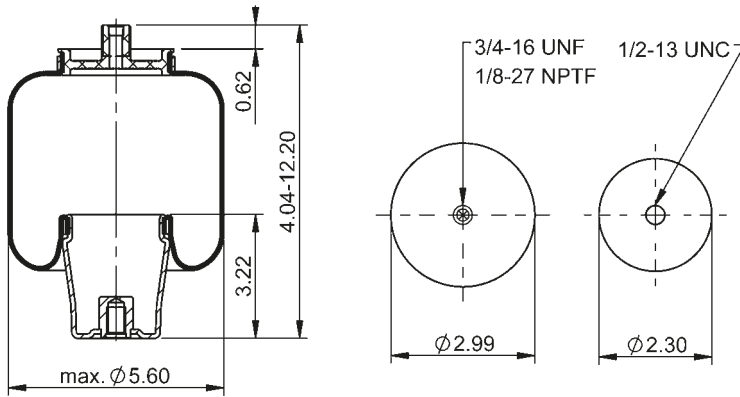

78413



**lb** 2.4 lb **No.** 9313039

**Cross-reference | Cruce de Referencia**  
 Firestone W02-358-7044

**Manufacturer | Fabricante**  
 Link 1102-0070

1/8-27 NPTF: max. 1.5 lb-ft  
 1/2-13 UNC: max. 18 lb-ft  
 3/4-16 UNF: max. 9 lb-ft

### SC29-Y064

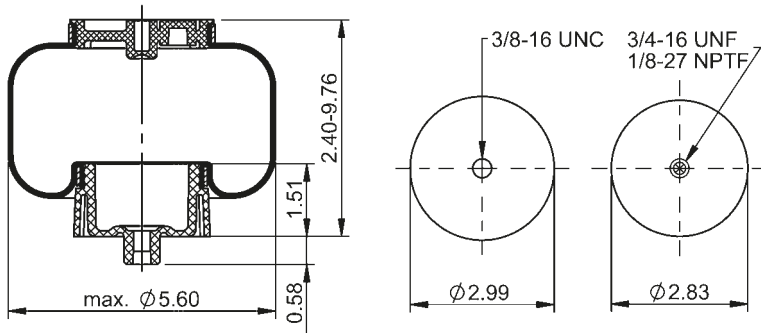

67768



**lb** 0.7 lb **No.** 9309740

**Cross-reference | Cruce de Referencia**  
 Firestone W02-358-7064  
 Goodyear 1S5-157

**Manufacturer | Fabricante**  
 Kenworth ~~AMERICAN~~ CAB (Mid 1999 &  
 Link 1102-0074

1/8-27 NPTF: max. 1.5 lb-ft  
 3/8-16 UNC: max. 3.5 lb-ft  
 3/4-16 UNF: max. 9 lb-ft

### SC29-Y082

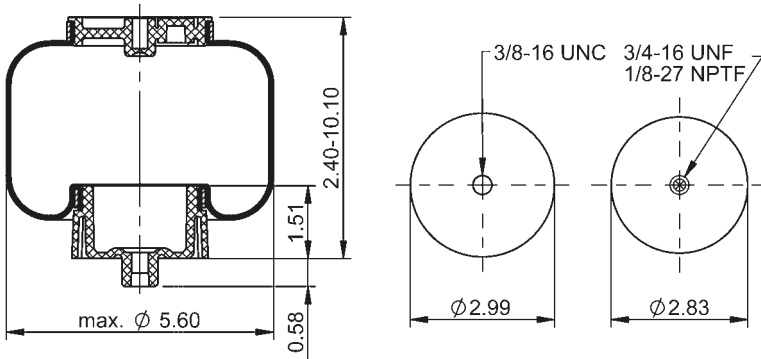

67853



**lb** 0.7 lb **No.** 9309740

**Cross-reference | Cruce de Referencia**  
 Firestone W02-358-7082

**Manufacturer | Fabricante**  
 Freightliner 66003-3405

1/8-27 NPTF: max. 1.5 lb-ft  
 3/8-16 UNC: max. 3.5 lb-ft  
 3/4-16 UNF: max. 9 lb-ft

### SC29-Y108

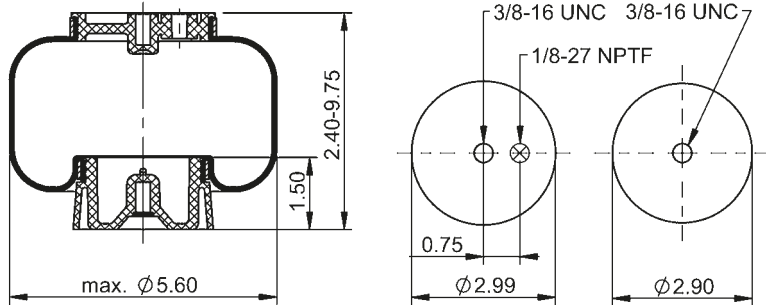

67852



**lb** 0.7 lb **No.** 9310094

**Cross-reference | Cruce de Referencia**  
 Firestone W02-358-7108  
 Goodyear 1S5-057

**Manufacturer | Fabricante**  
 Link 1102-0075  
 Milsco 07067A

1/8-27 NPTF: max. 1.5 lbft  
 3/8-16 UNC: max. 3.5 lbft

### SC29-Y109

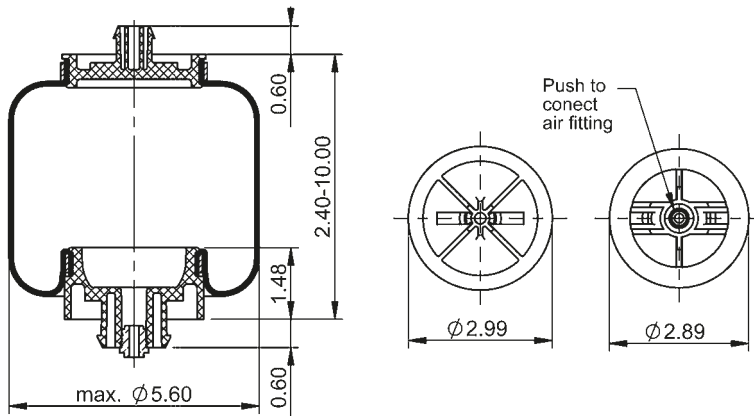

69624



**lb** 0.9 lb **No.** 9312922

**Cross-reference | Cruce de Referencia**  
 Firestone W02-358-7109

**Manufacturer | Fabricante**  
 Kenworth AEROCAB (Mid 1999 & later)  
 T811000  
 Link 1102-0077  
 1104-K002

### SC29-YC07

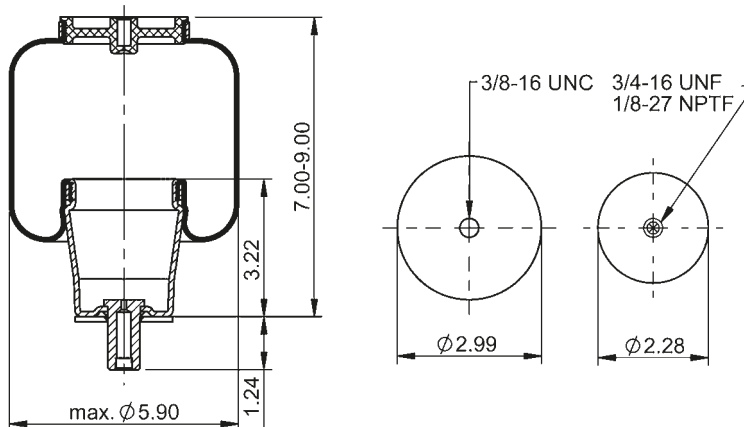

75707



**lb** 1.8 lb **No.** 9313363

**Manufacturer | Fabricante**  
 Link 1102-1001

1/8-27 NPTF: max. 1.5 lbft  
 3/8-16 UNC: max. 3.5 lbft  
 3/4-16 UNF: max. 9 lbft

### SC29-YG01

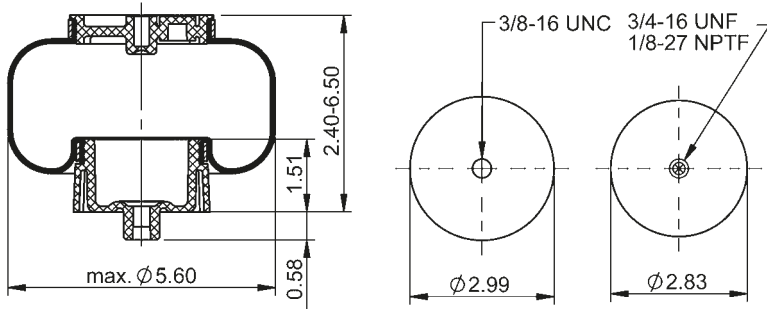

67882



**lb** 0.7 lb **No.** 9309740

**Cross-reference | Cruce de Referencia**

Goodyear 1S5-010

- 1/8-27 NPTF: max. 1.5 lb-ft
- 3/8-16 UNC: max. 3.5 lb-ft
- 3/4-16 UNF: max. 9 lb-ft

### SC29-YG02

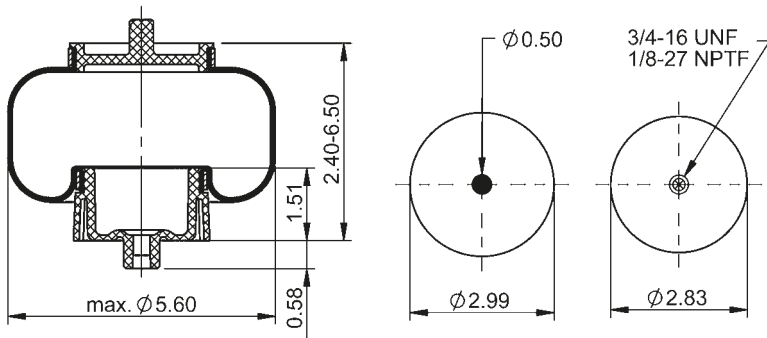

70825



**lb** 0.7 lb **No.** 9309740

**Cross-reference | Cruce de Referencia**

Goodyear 1S5-045

**Manufacturer | Fabricante**

Freightliner GYR1S5045

- 1/8-27 NPTF: max. 1.5 lb-ft
- 3/4-16 UNF: max. 9 lb-ft

### SC29-YG14

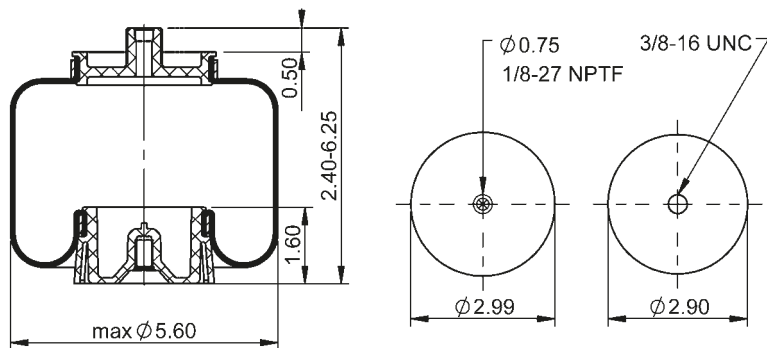

78410



**lb** 0.9 lb **No.** 9310094

**Cross-reference | Cruce de Referencia**

Goodyear 1S5-133

**Manufacturer | Fabricante**

Link 1101-0045

- 1/8-27 NPTF: max. 1.5 lb-ft
- 3/8-18 NPTF: max. 3.5 lb-ft



### SC31-BG10

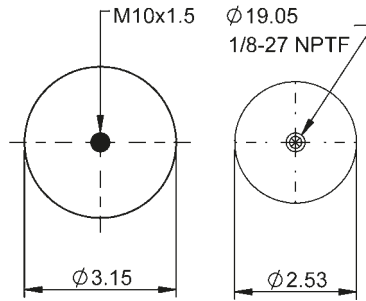
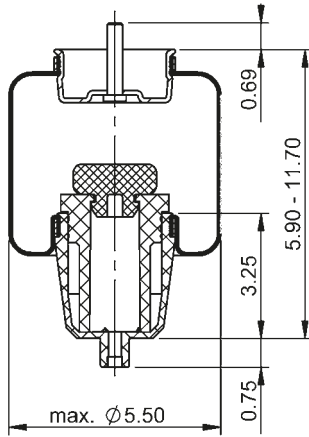

78421



**lb** 3.5 lb **No.** 9318931

**Cross-reference | Cruce de Referencia**

Goodyear 1S5-171

1/8-27 NPTF: max. 1.5 lbft  
M10: max. 3.5 lbft

### SC31-BG12

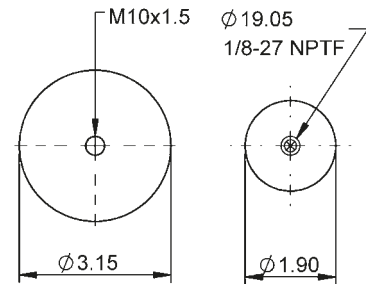
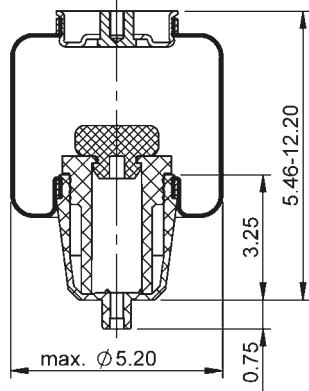

78423



**lb** 2.6 lb **No.** 9318931

**Cross-reference | Cruce de Referencia**

Goodyear 1S5-070

**Manufacturer | Fabricante**

Volvo 8169029

1/8-27 NPTF: max. 1.5 lbft  
M10: max. 3.5 lbft

### SC31-OG11

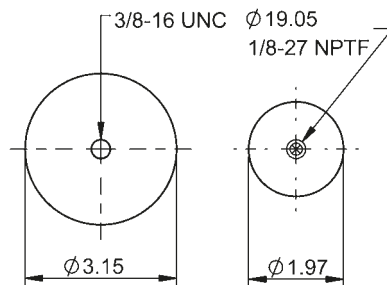
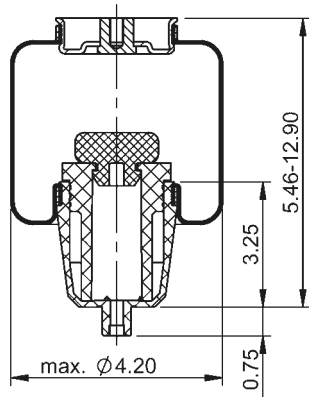

78422



**lb** 2.6 lb **No.** 9318931

**Cross-reference | Cruce de Referencia**

Goodyear 1S4-074

**Manufacturer | Fabricante**

Volvo 660003-3201

1/8-27 NPTF: max. 1.5 lbft  
M10: max. 3.5 lbft

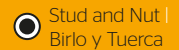
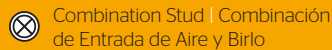
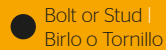

### SC31-W206

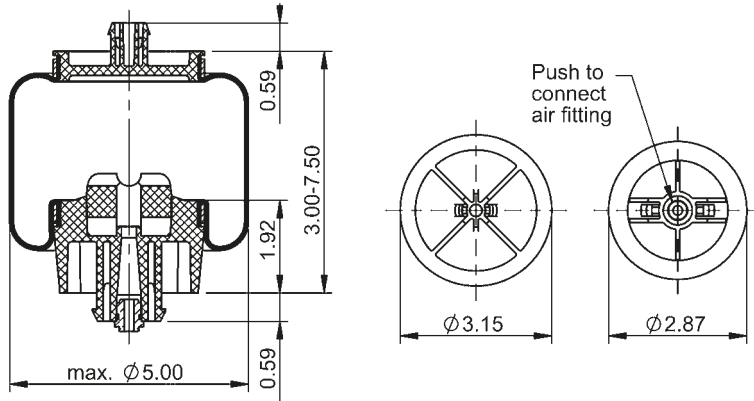

67452



**lb** 1.1 lb **No.** 9314152

**Cross-reference | Cruce de Referencia**

Firestone	W02-358-7202
	W02-358-7206
Goodyear	1S5-176

**Manufacturer | Fabricante**

Freightliner	18-29919-000
--------------	--------------

### SC31-Y205

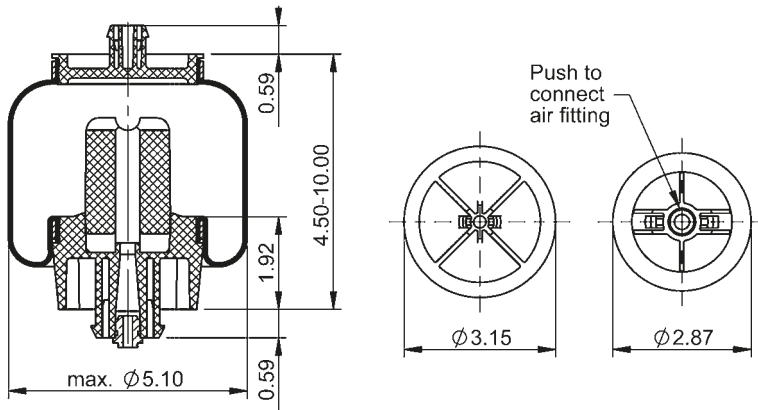

67638



**lb** 1.2 lb **No.** 9314152

**Cross-reference | Cruce de Referencia**

Firestone	W02-358-7205
-----------	--------------

**Manufacturer | Fabricante**

Freightliner	66003-3406
--------------	------------

### SC31-Y215

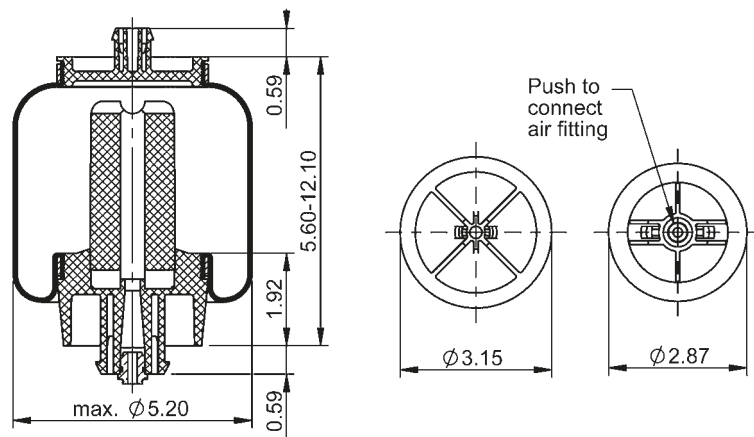

68161



**lb** 1.4 lb **No.** 9314152 **←** SC31-B207

**Cross-reference | Cruce de Referencia**

Firestone	W02-358-7207
	W02-358-7215
Goodyear	1S5-175

**Manufacturer | Fabricante**

Freightliner	18-40977-000
	18-52651-000
	18-66715-000

### SK 37-6 P02

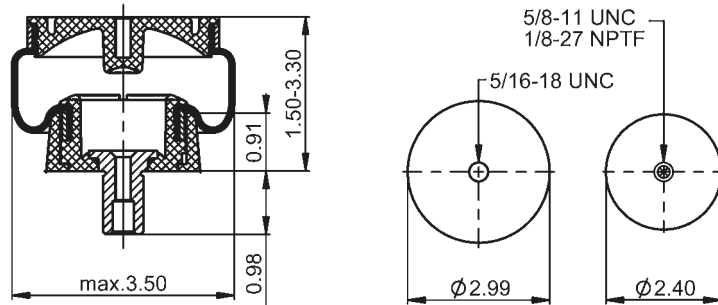

74324



**lb** 0.2 lb **No.** 9310238

**Cross-reference | Cruce de Referencia**  
 Firestone W02-358-3001  
 Goodyear 1S3-013

**Manufacturer | Fabricante**  
 Prevost 950208

1/8-27 NPTF: max. 1.5 lbft

### SK 125-101 P01

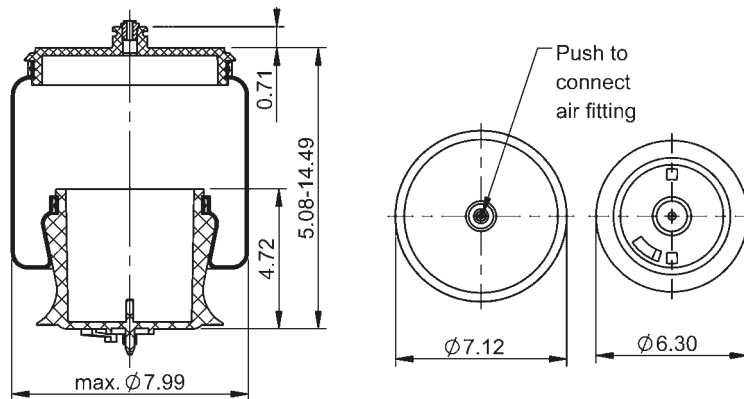

78360



**lb** 4.6 lb **No.** 9318648

**Cross-reference | Cruce de Referencia**  
 Firestone W26-358-9933

**Manufacturer | Fabricante**  
 Kenworth B81-6023  
 PACCAR



# Cross-reference

Referencias Cruzadas

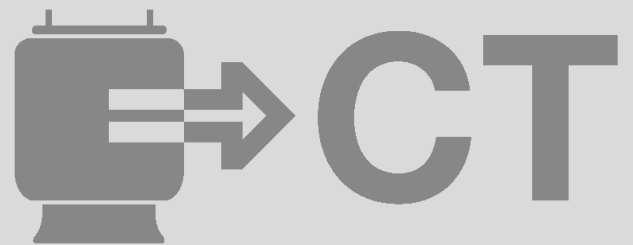

Firestone	CT	No.	2 3
W01-095-0021	6S 9.5-15.5 (661 N)	68461	32
W01-095-0087	6S 9.5-13	70129	32
W01-095-0118	5S 8-15.5 (644N)	66141	32
W01-358-0783	9 10-19 A 830	65807	158
W01-358-1096	9 10-17.5 A 802	64762	137
W01-358-1190	9 10S-18 P 1066 (BK)	73745	142
W01-358-1191	9 10S-18 P 1067 (BK)	73746	142
W01-358-1192	9 10S-18 P 1067 (BK)	73746	142
W01-358-2119	6 6.5B-11 S 027	68108	37
W01-358-2120	6 6.5-11 S 028	68109	33
W01-358-2131	6 6.5-11 S 029	68110	33
W01-358-5139	5S 8-15.5 (644N)	66141	32
W01-358-5150	6S 9.5-15.5 (661 N)	68461	32
W01-358-5158	6S 9.5-13	70129	32
W01-358-5297	6 6.5D-11 S 034	68115	38
W01-358-5298	6 6.5B-11 S 054	68135	37
W01-358-5300	6 6.5-11 S 048	68132	34
W01-358-5310	6 6.5-11 S 030	68111	33
W01-358-5311	6 6.5-11 S 031	68112	34
W01-358-5315	6 6.5-11 S 051	68133	35
W01-358-5316	6 6.5-11 S 052	68134	35
W01-358-5319	6 6.5B-11 S 035	68116	37
W01-358-5323	6 6.5-11 S 032	68113	34
W01-358-5405	6 6.5-13 S 038	68120	39
W01-358-5406	6 6.5-13 S 039	68121	39
W01-358-5408	6 6.5-13 S 040	68122	39
W01-358-5409	6 6.5-13 S 056	68136	42
W01-358-5410	6 6.5-13 S 446	68123	42
W01-358-5412	6 6.5-13 S 041	68124	40
W01-358-5414	6 6.5-13 S 042	68125	40
W01-358-5422	6 6.5-13 S 043	68126	40
W01-358-5423	6 6.5-13 S 559	68127	43
W01-358-5433	6 6.5-13 S 044	68128	41
W01-358-5434	6 6.5-13 S 045	68129	41
W01-358-5435	6 6.5-13 S 056	68136	42
W01-358-5436	6 6.5-13 S 046	68130	41
W01-358-5503	11 10.5-22 A 530	64422	209
W01-358-5505	11 10.5-22 S 750	64688	210
W01-358-5511	11 10.5-22 A 931	68159	211
W01-358-5514	11 10.5-22 A 752	64690	210
W01-358-5748	9 9L-10 P 1594	601536	47
W01-358-5766	9 9-12 P 1476	79614	55
W01-358-5770	9 9L-10 P 1150	74843	47

Firestone	CT	No.	2 3
W01-358-5789	9 9-9 P 767	64713	45
W01-358-6231	9 10-17.5 P 1388	78601	139
W01-358-6258	9 10-17.5 P 779	64729	136
W01-358-6262	9 10-17.5 P 831	65831	137
W01-358-6392	FD 200-25 1008	75184	245
W01-358-6393	FD 200-25 717	64702	244
W01-358-6703	FD 200-22 765	66662	240
W01-358-6761	FD 70-13 796	66660	222
W01-358-6789	FD 330-30 512	64540	254
W01-358-6799	FD 530-35 543	64605	261
W01-358-6800	FD 530-30 518	64591	259
W01-358-6801	FD 530-30 451	64590	259
W01-358-6803	FD 530-30 449	64589	259
W01-358-6805	FD 530-30 532	64593	260
W01-358-6808	FD 530-30 519	64592	260
W01-358-6817	FD 200-25 721	64622	244
W01-358-6850	FD 330-22 540	64502	251
W01-358-6856	FD 200-19 499	64515	233
W01-358-6883	FD 200-22 529	64558	239
W01-358-6884	FD 200-19 724	64712	236
W01-358-6886	FD 200-22 706	64665	239
W01-358-6890	FD 200-19 539	64520	235
W01-358-6897	FD 200-19 505	64517	234
W01-358-6900	FD 200-19 319	64271	231
W01-358-6902	FD 200-19 310	64509	231
W01-358-6905	FD 200-19 315	64510	231
W01-358-6908	FD 200-19 362	64511	232
W01-358-6910	FD 200-19 320	64267	232
W01-358-6926	FD 200-19 504	64516	234
W01-358-6927	FD 200-25 453	64553	242
W01-358-6932	FD 200-19 452	64514	233
W01-358-6935	FD 200-19 499	64515	233
W01-358-6940	FD 200-19 450	64513	233
W01-358-6941	FD 200-19 448	64512	232
W01-358-6943	FD 200-25 426	64549	241
W01-358-6944	FD 200-25 454	64554	243
W01-358-6945	FD 200-25 427	64550	241
W01-358-6946	FD 200-25 463	64555	243
W01-358-6947	FD 200-25 428	64551	242
W01-358-6948	FD 200-25 429	64552	242
W01-358-6949	FD 200-19 506	64518	234
W01-358-6960	FD 200-25 507	64556	243
W01-358-6962	FD 200-25 511	64557	244

Firestone	CT	No.	2 3
W01-358-6994	FS 330-11 467	64594	216
W01-358-7008	FS 330-11 474	64596	216
W01-358-7009	FS 330-11 468	64595	216
W01-358-7025	FD 70-13 918	73310	222
W01-358-7088	FS 530-14 517	64528	219
W01-358-7093	FS 530-14 515	64526	219
W01-358-7094	FS 530-14 538	64529	220
W01-358-7096	FS 530-14 516	64527	219
W01-358-7103	FS 530-14 442	64523	218
W01-358-7104	FS 530-14 446	64524	218
W01-358-7105	FS 530-14 447	64525	218
W01-358-7112	FS 530-14 339	64521	217
W01-358-7117	FS 530-14 361	64522	217
W01-358-7123	FD 530-22 345	64547	258
W01-358-7135	FD 530-22 311	64543	257
W01-358-7136	FD 530-22 321	64545	257
W01-358-7140	FD 530-22 316	64544	257
W01-358-7145	FD 530-22 374	64548	258
W01-358-7146	FD 530-22 342	64546	258
W01-358-7180	FD 330-22 363	64493	248
W01-358-7181	FD 330-22 472	64500	250
W01-358-7183	FD 330-22 471	64499	250
W01-358-7184	FD 330-22 780	66300	251
W01-358-7325	FD 120-20 509	64601	229
W01-358-7344	FD 330-22 500	64501	251
W01-358-7400	FD 330-22 313	64270	245
W01-358-7401	FD 330-22 337	64490	247
W01-358-7403	FD 330-22 318	64488	246
W01-358-7404	FD 330-22 346	64492	248
W01-358-7405	FD 330-22 364	64494	248
W01-358-7406	FD 330-22 365	64495	249
W01-358-7408	FD 330-22 366	64496	249
W01-358-7409	FD 330-22 367	64497	249
W01-358-7410	FD 330-22 331	64268	246
W01-358-7423	FD 330-22 368	64498	250
W01-358-7424	FD 330-22 327	64283	246
W01-358-7429	FD 330-22 343	64491	247
W01-358-7437	FD 330-22 334	64489	247
W01-358-7443	FD 330-30 323	64531	252
W01-358-7444	FD 330-30 369	64533	252
W01-358-7446	FD 330-30 370	64534	253
W01-358-7447	FD 330-30 340	64532	252
W01-358-7472	FD 330-30 371	64535	253

Firestone	CT	No.	2 3
W01-358-7473	FD 330-30 372	64536	253
W01-358-7483	FD 330-30 373	64537	254
W01-358-7499	FD 330-30 502	64539	254
W01-358-7505	FD 110-17A 789	67553	228
W01-358-7545	FD 331-26 514	64597	256
W01-358-7550	FD 331-26 541	64599	256
W01-358-7555	FD 331-26 480	64284	256
W01-358-7557	FD 530-35 530	64604	261
W01-358-7659	FD 110-17A 775	67667	228
W01-358-7667	9 10-12 P 720	64646	85
W01-358-7686	FD 200-19 712	64685	235
W01-358-7689	FD 120-20 795	66661	230
W01-358-7705	FD 120-20 715	64666	230
W01-358-7781	FD 530-35 545	64607	262
W01-358-7782	FD 530-35 544	64606	261
W01-358-7788	FD 200-19 510	64519	235
W01-358-7790	FD 330-30 513	64541	255
W01-358-7795	FD 200-19 713	67705	236
W01-358-7796	FT 530-32 536	64508	277
W01-358-7797	FT 530-32 535	64507	277
W01-358-7798	FT 530-32 329	64504	276
W01-358-7800	FT 530-32 333	64505	276
W01-358-7808	FT 530-32 336	64506	277
W01-358-7818	FT 530-32 325	64503	276
W01-358-7838	FT 530-35 436	64576	278
W01-358-7839	FT 530-35 437	64577	278
W01-358-7843	FT 530-35 455	64581	280
W01-358-7844	FT 530-35 438	64578	279
W01-358-7845	FT 530-35 521	64584	281
W01-358-7846	FT 530-35 456	64582	280
W01-358-7847	FT 530-35 457	64583	280
W01-358-7848	FT 530-35 439	64579	279
W01-358-7850	FT 530-35 441	64580	279
W01-358-7853	FT 530-35 537	64588	282
W01-358-7855	FT 530-35 522	64585	281
W01-358-7859	FT 530-35 523	64586	281
W01-358-7862	FT 530-35 534	64587	282
W01-358-7872	FT 530-35 726	65828	282
W01-358-7891	FD 200-22A 1062	78246	240
W01-358-7897	FD 200-23A 709	64683	241
W01-358-7990	FT 330-29 703	64648	271
W01-358-7994	FT 330-29 546	64572	270
W01-358-7995	FT 330-29 547	64573	270

Firestone	CT	No.	2 3
W01-358-7996	FT 330-29 520	64570	269
W01-358-7996	FT 330-29 723	64710	272
W01-358-7998	FT 330-29 548	64574	270
W01-358-8006	FT 330-29 430	64561	266
W01-358-8008	FT 330-29 431	64562	266
W01-358-8010	FT 330-29 432	64563	267
W01-358-8014	FT 330-29 874	69630	273
W01-358-8016	FT 330-29 433	64564	267
W01-358-8018	FT 330-29 434	64285	267
W01-358-8025	FT 330-29 469	64566	268
W01-358-8027	FT 330-29 466	64565	268
W01-358-8030	FT 330-29 498	64567	268
W01-358-8032	FT 330-29 413	64560	266
W01-358-8033	FT 330-29 525	64571	269
W01-358-8033	FT 330-29 714	67904	271
W01-358-8038	FT 330-29 554	66522	271
W01-358-8039	FT 330-29 875	69641	274
W01-358-8042	FT 330-29 790	69747	273
W01-358-8047	FT 430-35 1178	77340	274
W01-358-8050	11 10.5C-16 A 320	64254	191
W01-358-8051	11 10.5C-16 A 385	64359	192
W01-358-8052	11 10.5C-16 A 378	64357	191
W01-358-8053	11 10.5C-16 A 380	64358	192
W01-358-8056	11 10.5C-16 A 729	64660	193
W01-358-8088	11 10.5-15 A 419	64425	188
W01-358-8091	11 10.5A-16 P 523	64421	190
W01-358-8093	11 10.5B-18 P 743	65368	201
W01-358-8184	9 10S-14 S 1574 (BK)	600932	107
W01-358-8197	9 10-12 P 024	68009	77
W01-358-8201	9 10-12 P 483	64455	82
W01-358-8203	9 10-12 P 543	64462	84
W01-358-8204	9 10-12 P 484	64456	82
W01-358-8207	9 10-12 P 1291	77433	87
W01-358-8478	9 9M-13 P 1283	77202	58
W01-358-8539	10 10.5AV-16 P 1219	78239	185
W01-358-8591	9 10-16 P 1309	77699	119
W01-358-8617	10 10.5C-13 P 1226	75741	184
W01-358-8636	10 10-13 S 1614	601634	168
W01-358-8637	10 10-16 S 724	64649	178
W01-358-8646	9 10-12 P 932	67696	86
W01-358-8708	10 10-16 P 526	64638	177
W01-358-8709	10 10.5-15 P 460	64645	185
W01-358-8710	10 10-15 P 711	64635	173

Firestone	CT	No.	2 3
W01-358-8713	10 10-16 P 533	64636	177
W01-358-8723	10 10-15 S 962	67600	174
W01-358-8729	10 10A-12 P 1330	77963	168
W01-358-8735	10 10-16.5 S 262	70010	180
W01-358-8740	10 10-15 S 773	64725	174
W01-358-8744	10 10-21 P 964	67624	184
W01-358-8746	10 10-21 P 774	64728	183
W01-358-8748	10 10-21 P 570	64252	183
W01-358-8749	10 10-21 P 486	64419	182
W01-358-8751	10 10-15 P 453	64624	172
W01-358-8752	10 10-15 S 518	64396	172
W01-358-8753	10 10-15 S 713	64639	173
W01-358-8755	10 10-15 P 522	64397	173
W01-358-8760	11 10.5-13 A 1132	74618	187
W01-358-8764	11 10.5-21 A 025	68010	205
W01-358-8774	11 10.5F-17 P 745	65593	200
W01-358-8778	11 10.5-17 A 507	64350	199
W01-358-8779	11 10.5-19 A 508	64393	202
W01-358-8780	11 10.5-19 A 509	64289	203
W01-358-8781	11 10.5-19 A 557	65360	203
W01-358-8782	10 10-15 S 871	66340	174
W01-358-8792	11 10.5-21 A 313	64273	206
W01-358-8800	9 10-13.5 S 881	66447	90
W01-358-8802	9 10-14 P 469	64477	98
W01-358-8803	9 10-14 P 489	64478	98
W01-358-8805	9 10-14 P 462	64474	97
W01-358-8806	9 10-14 A 545	64486	101
W01-358-8810	9 10-14 A 546	64487	101
W01-358-8813	9 10-14 P 577	65990	102
W01-358-8816	9 10-14 P 905 (BK)	68153	104
W01-358-8817	9 10-14 P 906 (BK)	68154	104
W01-358-8824	9 10-16 P 1602	601539	119
W01-358-8825	9 10-16 P 769	64650	117
W01-358-8829	9 10S-17 P 1154 (BK)	74884	126
W01-358-8842	9 10-19 P 765	64711	156
W01-358-8852	9 10-19 P 472	64339	155
W01-358-8855	9 10-19 P 552	64340	155
W01-358-8856	9 10-19 P 553	64341	156
W01-358-8861	9 10-19 P 762	64708	156
W01-358-8864	9 10-19 P 898	66666	158
W01-358-8882	9 10-12 P 839	66117	86
W01-358-8888	9 10-17.5 P 904	66700	138
W01-358-8897	9 9-12 P 730	64664	53



Firestone	CT	No.	2 3
W01-358-8900	9 9-12 P 401	64362	49
W01-358-8901	9 9-12 P 464	64364	50
W01-358-8903	9 10-17.5 P 536	64423	133
W01-358-8919	9 9-14 P 517	64381	60
W01-358-8924	9 10-16 P 497	64314	115
W01-358-8927	9 10-16 P 498	64315	115
W01-358-8930	9 10-12 P 396	64452	81
W01-358-8931	9 10-12 A 1284	77203	87
W01-358-8932	9 10-12 P 485	64457	83
W01-358-8934	9 10-12 P 544	64463	84
W01-358-8942	9 9-14 P 1319	77797	64
W01-358-8943	9 9-14 P 1094	74328	62
W01-358-8944	9 10-17.5 P 436	64401	130
W01-358-8949	9 9K-15 P 455	64390	66
W01-358-8959	9 9K-12 P 100	68617	56
W01-358-8961	9 10-10 P 542	64658	75
W01-358-8963	9 10-10 P 473	64440	74
W01-358-8964	9 10-10 P 480	64441	74
W01-358-8965	9 9K-16 P 1568	600804	68
W01-358-8971	9 10-10 P 204	69625	70
W01-358-8976	9 10-10 P 503	64444	75
W01-358-8986	9 10-10 P 400	64438	73
W01-358-8992	6 6.5D-11 S 037	68118	38
W01-358-8997	6 6.5D-11 S 525	68119	38
W01-358-9004	9 10-16 P 394	64307	113
W01-358-9008	9 10-14 P 344	64466	94
W01-358-9010	9 10-14 P 345	64258	94
W01-358-9011	9 10-14 P 346	64467	94
W01-358-9015	9 10-17.5 P 436	64401	130
W01-358-9017	9 9K-15 P 1147	74792	67
W01-358-9026	9 10-16 P 393	64306	112
W01-358-9029	9 10-10 P 399	64437	73
W01-358-9031	9 10-10 P 339	64433	72
W01-358-9033	9 10-10 P 328	64430	71
W01-358-9039	9 10-10 P 311	64260	70
W01-358-9049	9 9M-13 P 1196	75412	58
W01-358-9053	9 10-12 A 327	64446	79
W01-358-9059	9 10-14 P 335	64465	93
W01-358-9063	9 10-14 P 347	65364	95
W01-358-9068	9 10-14 P 348	64468	95
W01-358-9069	9 10-14 P 312	64274	93
W01-358-9070	9 10-14 A 330	64464	93
W01-358-9071	9 10-14 P 349	64469	95

Firestone	CT	No.	2 3
W01-358-9073	9 9M-13 P 1181	75179	57
W01-358-9075	9 9-12 A 334	64360	48
W01-358-9077	9 10-10 P 331	64431	71
W01-358-9078	9 10-12 P 329	64447	79
W01-358-9082	9 10-16 P 310	64269	108
W01-358-9083	9 10-16 P 333	64294	109
W01-358-9092	9 10-16 P 372	64301	111
W01-358-9093	9 10-16 P 332	64293	109
W01-358-9096	9 10-16 P 325	64292	108
W01-358-9100	9 10-12 P 1145	74790	87
W01-358-9101	9 10-19 P 315	64279	150
W01-358-9105	9 10-12 P 319	64445	78
W01-358-9113	9 10-12 A 341	64448	79
W01-358-9116	11 10.5-17 A 556	64351	200
W01-358-9118	9 10-12 A 342	64449	80
W01-358-9121	11 10.5-17 A 317	64272	197
W01-358-9122	11 10.5-21 A 313	64273	206
W01-358-9127	9 10-12 A 707	64633	85
W01-358-9127	9 10-12 P 707	69541	85
W01-358-9130	9 10-19 P 321	64280	150
W01-358-9134	11 10.5-19 A 431	64391	202
W01-358-9135	11 10.5-17 A 368	65358	198
W01-358-9138	11 10.5-19 A 432	64392	202
W01-358-9144	11 10.5-17 A 377	64347	198
W01-358-9148	11 10.5-17 A 364	64343	197
W01-358-9149	11 10.5-17 A 365	64344	197
W01-358-9153	11 10.5-21 A 1339	78046	208
W01-358-9156	11 10.5-21 A 370	64354	207
W01-358-9158	11 10.5-21 A 318	64352	206
W01-358-9164	11 10.5-17 A 405	64349	199
W01-358-9177	11 10.5-17 A 316	64342	196
W01-358-9179	11 10.5-17 A 316	64342	196
W01-358-9192	9 10-19 P 326	64323	150
W01-358-9193	9 10-16 P 351	64296	109
W01-358-9194	9 10-16 P 352	64297	110
W01-358-9199	11 10.5-21 A 558	64356	207
W01-358-9200	11 10.5-15 A 415	64253	188
W01-358-9201	11 10.5-21 A 219	69746	206
W01-358-9203	9 10-19 P 355	64324	151
W01-358-9204	11 10.5-15 A 506	64429	190
W01-358-9213	9 10-16 P 441	64308	115
W01-358-9215	11 10.5-15 A 414	64424	188
W01-358-9216	11 10.5-15 A 421	64427	189

Firestone	CT	No.	2 3
W01-358-9218	11 10.5-15 A 422	64428	189
W01-358-9219	9 10-16 P 408	64259	113
W01-358-9221	11 10.5-17 A 388	64348	199
W01-358-9223	9 10-16 P 409	64275	114
W01-358-9227	9 10-16 P 353	64298	110
W01-358-9228	9 10-16 A 354	64299	110
W01-358-9238	9 10-19 P 356	64325	151
W01-358-9240	9 10-19 P 357	64326	151
W01-358-9241	9 10-19 P 358	64615	152
W01-358-9241	9 10-19 P 383	64281	153
W01-358-9243	9 10-19 P 1138	74663	160
W01-358-9245	9 10-19 P 390	64331	153
W01-358-9249	9 10-10 S 221	69767	70
W01-358-9250	9 10D-21 A 324	64375	166
W01-358-9252	9 10D-21 A 363	64376	167
W01-358-9256	9 10-16 P 371	64300	111
W01-358-9264	11 10.5-24 S 712	64637	213
W01-358-9265	9 10-19 P 435	64288	153
W01-358-9269	9 10D-21 A 555	64377	167
W01-358-9270	9 10-13.5 S 433	64287	89
W01-358-9274	9 10B-17.5 A 362	65359	140
W01-358-9275	9 10B-17.5 A 323	64371	140
W01-358-9277	11 10.5-15 A 420	64426	189
W01-358-9287	9 10-18.5 P 406 (BK)	68615	144
W01-358-9290	9 9M-13 P 1290	77427	59
W01-358-9291	9 9K-15 P 425	64389	66
W01-358-9293	9 9K-15 P 424	64388	65
W01-358-9294	9 9K-15 P 423	64387	65
W01-358-9295	9 9K-15 P 417	64386	65
W01-358-9296	9 10-16 P 416 (BK)	69643	114
W01-358-9297	9 10-18.5 P 935 (BK)	66978	146
W01-358-9299	9 10-16 P 710	64634	117
W01-358-9302	9 10-12 P 343	64450	80
W01-358-9303	9 10-13.5 P 1394	78638	90
W01-358-9304	9 10-16 P 392	64305	112
W01-358-9307	9 10-10 P 471	64439	73
W01-358-9307	9 10-10.5 P 883	67490	76
W01-358-9308	9 10-10 P 398	64436	72
W01-358-9320	9 10-21 P 360	64382	162
W01-358-9321	9 10-21 A 361	64715	162
W01-358-9325	9 10-12 P 395	64451	80
W01-358-9332	9 10-10 P 397	64435	72
W01-358-9333	9 10-10 P 481	64442	74

Firestone	CT	No.	2 3
W01-358-9334	9 10-10 P 482	64443	75
W01-358-9335	9 10-14 P 465 (BK)	69644	97
W01-358-9336	9 10-14 P 490	64479	98
W01-358-9338	9 10-21 P 511	64385	164
W01-358-9339	9 10-12 P 487 (BK)	69645	83
W01-358-9342	9 10-17.5 P 418	64334	128
W01-358-9346	9 10-19 P 470	64338	154
W01-358-9348	9 10-19 P 439	65356	154
W01-358-9349	9 10-19 P 438	64335	154
W01-358-9350	9 10-19 P 359	64328	152
W01-358-9362	9 10-16 P 391	64304	112
W01-358-9364	9 10-16 P 392	64305	112
W01-358-9365	9 10-12 P 495	64460	84
W01-358-9366	9 10-12 P 488	64459	83
W01-358-9367	9 10-21 A 505	64716	163
W01-358-9370	9 10-21 P 448	64383	163
W01-358-9371	9 10-18.5 P 521 (BK)	69646	145
W01-358-9373	9 10-18.5 P 519 (BK)	64265	144
W01-358-9375	9 10-18.5 P 451 (BK)	68616	144
W01-358-9376	9 9-12 P 477	64365	50
W01-358-9377	9 9-12 P 478	64366	50
W01-358-9378	9 9-12 P 447	64363	49
W01-358-9379	9 9-12 P 379	64361	49
W01-358-9387	9 9-12 P 479	64367	51
W01-358-9392	9 10-16 P 376	64302	111
W01-358-9394	9 10-19 P 383	64281	153
W01-358-9415	9 9-14 P 322	64378	60
W01-358-9421	9 9-12 P 705	64627	52
W01-358-9422	9 9-12 P 314	64255	48
W01-358-9439	9 9-14 A 337	64379	60
W01-358-9441	9 9-14 P 1146	74791	63
W01-358-9448	9 9-12 P 563	64286	52
W01-358-9463	9 10-14 P 437	64471	96
W01-358-9466	9 10-16 P 410	64276	114
W01-358-9467	9 10-14 A 491	64480	99
W01-358-9469	9 10-14 A 103	68620	91
W01-358-9470	9 10-17.5 P 501 (BK)	69647	132
W01-358-9471	9 10-17.5 P 502 (BK)	69648	132
W01-358-9472	9 10-17.5 P 467 (BK)	69649	131
W01-358-9473	9 10-17.5 P 445 (BK)	69650	130
W01-358-9474	9 10-16 P 500	64317	116
W01-358-9476	9 9-12 P 516	64368	51
W01-358-9478	6 6.5-13 S 047	68131	42

Firestone	CT	No.	2 3
W01-358-9482	9 10-14 P 492 (BK)	69651	99
W01-358-9483	9 10-14 P 493	64482	99
W01-358-9484	9 10-14 P 494	64483	100
W01-358-9491	9 10B-17.5 P 554 (BK)	69652	140
W01-358-9496	9 10-16 P 547 (BK)	69653	116
W01-358-9501	9 10-17.5 P 572 (BK)	69662	134
W01-358-9502	9 10-17.5 P 571	64415	134
W01-358-9504	9 10-17.5 P 574 (BK)	69654	135
W01-358-9507	9 10-14 P 718 (BK)	64644	102
W01-358-9507	9 10-14 PT75 (BK)	64621	106
W01-358-9529	FD 530-35 1165	77199	263
W01-358-9534	9 10-10 P 717	64643	76
W01-358-9539	9 9M-13 P 1156	75007	57
W01-358-9541	9 9-10 P 861 (BK)	68357	46
W01-358-9547	9 9-9 P 859 (BK)	68358	45
W01-358-9554	9 9K-12 P 093	68608	56
W01-358-9565	9 9-12 P 206	69627	48
W01-358-9567	9 10-14 P 461	64473	97
W01-358-9568	9 10-14 P 450	64472	96
W01-358-9579	9 10-13.5 S 881	66447	90
W01-358-9580	10 10-21 P 434	64394	182
W01-358-9581	10 10-21 P 015	67951	181
W01-358-9592	9 9K-15 P 1298	77616	67
W01-358-9616	9 9-12 P 515	64256	51
W01-358-9617	9 9-9 P 860 (BK)	69656	45
W01-358-9618	9 9-10 P 862 (BK)	69657	47
W01-358-9619	9 9B-22 P 741	64697	69
W01-358-9621	9 9B-20 P 740	64696	69
W01-358-9622	9 9-9 P 537 (BK)	68359	44
W01-358-9625	9 9-10 P 538 (BK)	68360	46
W01-358-9626	9 9-16 P 568	64692	68
W01-358-9634	9 10-14 P 575	65361	101
W01-358-9640	9 10-12 A 427	64395	81
W01-358-9641	9 10-18.5 P 1322	77861	147
W01-358-9643	9 10-16 P 549 (BK)	69658	117
W01-358-9644	9 10BP-16 P 569	64693	120
W01-358-9645	9 10BP-22 P 739	64695	167
W01-358-9646	9 10BP-20 P 738	64694	162
W01-358-9647	9 10-18.5 P 550 (BK)	69659	145
W01-358-9648	9 10S-16 P 1068 (BK)	73770	122
W01-358-9649	9 10-18.5 P 551	64414	145
W01-358-9650	9 9-12 P 1292	77432	55
W01-358-9651	9 9-9 P 756	64700	44

Firestone	CT	No.	2 3
W01-358-9652	9 9M-13 P 1182	75180	57
W01-358-9654	9 10-18.5 P 097	68614	143
W01-358-9663	9 10-18.5 P 939 (BK)	67573	146
W01-358-9675	9 9-10 P 576 (BK)	68361	46
W01-358-9697	9 10-14 P 882	66521	103
W01-358-9774	9 10-13.5 P 232	69800	88
W01-358-9780	9 10S-16 P 382	67473	121
W01-358-9781	9 10S-16 A 382	64266	120
W01-358-9782	9 10S-16 S 382	77614	121
W01-358-9797	9 10-14 A 496	64484	100
W01-358-9798	9 10-14 P 381	64470	96
W01-358-9804	11 10.5-19 A 960	67547	203
W01-358-9807	9 10-13.5 P 874	68151	89
W01-358-9811	11 10.5-17 A 208	69629	196
W01-358-9865	9 10BS-17 P 1192 (BK)	75266	124
W01-358-9866	9 10BS-17 P 1193	75267	124
W01-358-9867	9 10BS-17 P 1193 (BK)	77593	125
W01-358-9891	11 10.5-22 S 1009	70771	211
W01-358-9902	9 10-17.5 P 426	64398	128
W01-358-9915	11 10.5-24 S 276	70118	212
W01-358-9921	9 10-17.5 P 443	64402	130
W01-358-9922	9 10-17.5 P 428	64399	129
W01-358-9923	9 10-17.5 P 429	64278	129
W01-358-9929	11 10.5-24 S 277	70119	213
W01-358-9935	9 10-17.5 P 548	64412	133
W01-358-9936	9 10-17.5 P 454	64405	131
W01-358-9942	9 10-17.5 P 430	64400	129
W01-358-9943	9 10-17.5 P 475	64407	132
W01-358-9944	9 10-16 P 510	64318	116
W01-358-9947	9 10-17.5 P 732 (BK)	64669	135
W01-358-9947	9 10-17.5 P 452	64404	131
W01-358-9948	9 10-17.5 A 535	64411	133
W01-358-9959	9 10-14 P 188	69493	91
W01-358-9961	11 10.5-17 A 367	64346	198
W01-358-9966	9 10-17.5 P 731 (BK)	64668	135
W01-358-9972	9 10-17.5 P 023	68158	126
W01-358-9974	9 10-17.5 A 930	67586	138
W01-358-9978	9 10-14 P 959	67588	105
W01-377-9759	9 10S-16 P 999	68208	122
W01-653-9446	9 9-12 P 1155	74911	55
W01-M58-8463	9 10S-17 P 1153 (BK)	74883	125
W01-M58-8468	9 10S-17 P 1206	75561	126
W01-M58-9372	9 10-18.5 P 095 (BK)	68612	142

Firestone	CT	No.	2 3
W01-M58-9656	9 10-18.5 P 096 (BK)	68613	143
W01-W35-8497	9 9-14 P 191	69511	59
W01-W35-8739	10 10U-13 P 189	69494	169
W01-W35-8754	10 10-15 P 1140	74765	175
W01-W35-8809	9 10-14 P 1143	74768	105
W01-W35-8937	9 10-12 P 190	69495	78
W01-W35-8953	9 9-14 P 1144	74769	63
W01-W35-9060	9 10-14 P 709	64632	102
W01-W35-9236	11 10.5-15 A 1141	74766	190
W01-W35-9385	9 9-14 P 895	67492	62
W01-W35-9465	9 9-14 P 708	64631	61
W01-W35-9468	9 9-14 P 1142	74767	62
W02-358-3001	SK 37-6 P02	74324	307
W02-358-7001	SC29-O001	67770	290
W02-358-7002	SC29-O001	67770	290
W02-358-7003	SC29-O055	69926	292
W02-358-7007	SC29-R007	70014	296
W02-358-7031	SC29-O001	67770	290
W02-358-7032	SC29-W032	69928	297
W02-358-7035	SC29-W035	67851	297
W02-358-7036	SC29-Y036	68162	301
W02-358-7037	SC29-W037	70017	298
W02-358-7040	SC29-O040	70019	290
W02-358-7041	SC29-O041	69417	291
W02-358-7042	SC29-W042	70020	298
W02-358-7043	SC29-Y043	69932	301
W02-358-7044	SC29-Y044	78413	302
W02-358-7045	SC29-W045	69929	298
W02-358-7049	SC29-O049	69925	291
W02-358-7050 (Plastic)	SC29-O055	69926	292
W02-358-7054	SC29-O054	69923	291
W02-358-7055	SC29-O055	69926	292
W02-358-7056	SC29-W056	69930	299
W02-358-7061	SC29-W061	67861	299
W02-358-7064	SC29-Y064	67768	302
W02-358-7067	SC29-W067	69931	299
W02-358-7073	SC29-O073	69927	292
W02-358-7074	SC29-W074	69416	300
W02-358-7075	SC29-W075	67859	300
W02-358-7076	SC29-O076	78411	292
W02-358-7080	SC29-R080	78412	297
W02-358-7082	SC29-Y082	67853	302
W02-358-7083	SC29-B083	78414	287

Firestone	CT	No.	2 3
W02-358-7086	SC29-O086	67858	293
W02-358-7087	SC29-W087	67636	300
W02-358-7092	SC29-B092	67854	288
W02-358-7093	SC29-B093	75313	288
W02-358-7098	SC29-O098	69924	293
W02-358-7100	SC29-O100	67637	293
W02-358-7103	SC29-W103	67860	301
W02-358-7108	SC29-Y108	67852	303
W02-358-7109	SC29-Y109	69624	303
W02-358-7110	SC29-B110	69437	288
W02-358-7116	SC29-P116	601575	296
W02-358-7132	SC29-O132	75315	294
W02-358-7150	SC29-O150	70021	294
W02-358-7152	SC29-B152	67862	289
W02-358-7155	SC29-O155	75314	294
W02-358-7200	SC29-B200	67767	289
W02-358-7201	SC29-O201	67766	295
W02-358-7202	SC31-W206	67452	306
W02-358-7205	SC31-Y205	67638	306
W02-358-7206	SC31-W206	67452	306
W02-358-7207	SC31-Y215	68161	306
W02-358-7215	SC31-Y215	68161	306
W02-811-7041	SC29-O041	69417	291
W02-811-7150	SC29-O150	70021	294
W21-760-6401	FD 110-15 758	65391	227
W21-760-6781	FD 70-15 738	64735	223
W21-760-6873	FD 110-15 763	66092	227
W26-358-9911	6 6.5B-11 P 235	69914	36
W26-358-9912	6 6.5B-11 P 236	69915	36
W26-358-9913	6 6.5B-11 P 236	69915	36
W26-358-9933	SK 125-101 P01	78360	307

**Firestone bellows CT**

10.0" YELLOW	SC29-Y036	68162	301
10.00" ORANGE	SC29-O055	69926	292
10.00" ORANGE	SC29-O049	69925	291
10.00" ORANGE	SC29-B093	75313	288
10.12" WHITE	SC29-W074	69416	300
10.25" BLUE	SC29-B200	67767	289
10.43" YELLOW	SC31-Y215	68161	306
10.87" WHITE	SC29-W045	69929	298
10.87" WHITE	SC29-W032	69928	297
10.87" WHITE	SC29-W056	69930	299
11.00" ORANGE	SC29-O073	69927	292
11.5" WHITE	SC29-W067	69931	299
11.5" YELLOW	SC29-Y043	69932	301
11.75" BLUE	SC29-B110	69437	288
113	FS 530-14 446	64524	218
113	FS 530-14 447	64525	218
113	FS 530-14 442	64523	218
113-5	FS 530-14 515	64526	219
113-1	FS 530-14 516	64527	219
113-1	FS 530-14 538	64529	220
113-1	FS 530-14 339	64521	217
113B-1	FS 530-14 361	64522	217
113B-1	FS 530-14 517	64528	219
19	FS 330-11 474	64596	216
19	FS 330-11 468	64595	216
19	FS 330-11 467	64594	216
1R1C-335-310	6S 9.5-13	70129	32
1R1C-390-310	6S 9.5-15.5 (661 N)	68461	32
1T14C1	6 6.5-11 S 048	68132	34
1T14C-1	6 6.5B-11 S 027	68108	37
1T15AA-3	9 9M-13 P 1290	77427	59
1T15AA-3	9 9K-15 P 1147	74792	67
1T15CCR6	9 10SW-14 S 1574 (BK)	600932	107
1T15L-1.5	9 9-12 P 515	64256	51
1T15L-1.5	9 9-12 P 314	64255	48
1T15L-2	9 9-12 P 447	64363	49
1T15L-2	9 9-12 P 563	64286	52
1T15L-2	9 9-12 P 464	64364	50
1T15L-2	9 9-12 P 477	64365	50
1T15L-2	9 9-12 P 516	64368	51
1T15L-2	9 9-12 P 401	64362	49
1T15L-2	9 9-12 P 479	64367	51

**Firestone bellows CT**

1T15L-2	9 9-12 P 730	64664	53
1T15L-2	9 9-12 P 478	64366	50
1T15L-2	9 9-12 A 334	64360	48
1T15L-4	9 9-14 P 322	64378	60
1T15L-4	9 9-14 A 337	64379	60
1T15L-4	9 9-14 P 1146	74791	63
1T15L-4	9 9-14 P 517	64381	60
1T15L-4	9 9-14 P 1319	77797	64
1T15L-4	9 9-14 P 1094	74328	62
1T15L-4X	9 9-14 P 1144	74769	63
1T15L-4X	9 9-14 P 1142	74767	62
1T15L-4X	9 9-14 P 895	67492	62
1T15L-6	9 9-16 P 568	64692	68
1T15LA-0	9 9-10 P 861 (BK)	68357	46
1T15LA-0	9 9-10 P 576 (BK)	68361	46
1T15LA-01	9 9-10 P 862 (BK)	69657	47
1T15LA-1	9 9-9 P 859 (BK)	68358	45
1T15LA-1	9 9-9 P 537 (BK)	68359	44
1T15LA-1	9 9-9 P 860 (BK)	69656	45
1T15LB-10	9 9B-20 P 740	64696	69
1T15LC-12	9 9B-22 P 741	64697	69
1T15LC-2.5	9 9-12 P 206	69627	48
1T15LC-2.5	9 9-12 P 379	64361	49
1T15LC-4.5	9 10-14 P 461	64473	97
1T15LC-4.5	9 10-14 P 450	64472	96
1T15LP-2	9 9K-12 P 093	68608	56
1T15LP-2	9 9K-12 P 100	68617	56
1T15LP-3	9 9M-13 P 1182	75180	57
1T15LP-3	9 9M-13 P 1181	75179	57
1T15LP-3	9 9K-15 P 1298	77616	67
1T15LP-3	9 9M-13 P 1283	77202	58
1T15LP-3	9 9M-13 P 1290	77427	59
1T15LP-5	9 9K-15 P 417	64386	65
1T15LP-5	9 9K-15 P 425	64389	66
1T15LP-5	9 9K-15 P 455	64390	66
1T15LP-5	9 9K-15 P 423	64387	65
1T15LP-5	9 9K-15 P 424	64388	65
1T15M-0	9 10-10 P 339	64433	72
1T15M-0	9 10-10 P 397	64435	72
1T15M-0	9 10-10 P 480	64441	74
1T15M-0	9 10-10 P 399	64437	73
1T15M-0	9 10-10 P 311	64260	70
1T15M-0	9 10-10 P 398	64436	72

Firestone bellows	CT	No.	2 3
1T15M-0	9 10-10 P 482	64443	75
1T15M-0	9 10-10 P 542	64658	75
1T15M-0	9 10-10 P 717	64643	76
1T15M-0	9 10-10 P 328	64430	71
1T15M-0	9 10-10 P 473	64440	74
1T15M-0	9 10-10 P 400	64438	73
1T15M-0	9 10-10 P 503	64444	75
1T15M-0	9 10-10 P 331	64431	71
1T15M-0	9 10-10 P 481	64442	74
1T15M-05	9 10-10 P 471	64439	73
1T15M-1	9 10-12 P 839	66117	86
1T15M-1	9 10-10.5 P 883	67490	76
1T15M-11	9 10-21 A 505	64716	163
1T15M-11	9 10-21 P 360	64382	162
1T15M-11	9 10-21 P 448	64383	163
1T15M-11	9 10-21 P 511	64385	164
1T15M-11	9 10-21 P 361	64291	163
1T15M-11	9 10-21 A 361	64715	162
1T15M-2	9 10-12 P 484	64456	82
1T15M-2	9 10-12 A 327	64446	79
1T15M-2	9 10-12 P 319	64445	78
1T15M-2	9 10-12 P 343	64450	80
1T15M-2	9 10-13.5 P 874	68151	89
1T15M-2	9 10-12 P 488	64459	83
1T15M-2	9 10-12 P 487 (BK)	69645	83
1T15M-2	9 10-12 A 341	64448	79
1T15M-2	9 10-12 P 395	64451	80
1T15M-2	9 10-12 P 544	64463	84
1T15M-2	9 10-12 A 1284	77203	87
1T15M-2	9 10-12 P 483	64455	82
1T15M-2	9 10-12 A 342	64449	80
1T15M-2	9 10-12 P 329	64447	79
1T15M-2	9 10-12 P 485	64457	83
1T15M-2	9 10-12 P 720	64646	85
1T15M-2	9 10-12 P 024	68009	77
1T15M-2	9 10-12 P 1145	74790	87
1T15M-2	9 10-12 P 396	64452	81
1T15M-2	9 10-12 P 1291	77433	87
1T15M-2	9 10-12 P 495	64460	84
1T15M-2	9 10-12 P 543	64462	84
1T15M-4	9 10-14 A 546	64487	101
1T15M-4	9 10-14 P 906 (BK)	68154	104
1T15M-4	9 10-14 P 718 (BK)	64644	102

Firestone bellows	CT	No.	2 3
1T15M-4	9 10-14 P 1143	74768	105
1T15M-4	9 10-14 P 345	64258	94
1T15M-4	9 10-14 P 347	65364	95
1T15M-4	9 10-14 P 489	64478	98
1T15M-4	9 10-14 P 437	64471	96
1T15M-4	9 10-14 P 465 (BK)	69644	97
1T15M-4	9 10-14 P 349	64469	95
1T15M-4	9 10-14 P 312	64274	93
1T15M-4	9 10-14 P 882	66521	103
1T15M-4	9 10-14 P 494	64483	100
1T15M-4	9 10-14 P 344	64466	94
1T15M-4	9 10-14 P 346	64467	94
1T15M-4	9 10-14 P 381	64470	96
1T15M-4	9 10-14 P 577	65990	102
1T15M-4	9 10-14 P 462	64474	97
1T15M-4	9 10-14 A 545	64486	101
1T15M-4	9 10-14 P 905 (BK)	68153	104
1T15M-4	9 10-14 P 469	64477	98
1T15M-4	9 10-14 P 709	64632	102
1T15M-4	9 10-14 P 348	64468	95
1T15M-4	9 10-14 P 490	64479	98
1T15M-4	9 10-14 A 496	64484	100
1T15M-4	9 10-14 A 330	64464	93
1T15M-4	9 10-14 P 493	64482	99
1T15M-4	9 10-14 A 491	64480	99
1T15M-4	9 10-14 P 492 (BK)	69651	99
1T15M-4	9 10-14 P 335	64465	93
1T15M-6	9 10-16 P 510	64318	116
1T15M-6	9 10-16 P 351	64296	109
1T15M-6	9 10-16 P 441	64308	115
1T15M-6	9 10-16 P 310	64269	108
1T15M-6	9 10-16 P 393	64306	112
1T15M-6	9 10-16 P 371	64300	111
1T15M-6	9 10-16 P 1602	601539	119
1T15M-6	9 10-16 P 497	64314	115
1T15M-6	9 10-16 P 325	64292	108
1T15M-6	9 10-16 P 409	64275	114
1T15M-6	9 10-16 P 376	64302	111
1T15M-6	9 10-16 P 333	64294	109
1T15M-6	9 10-16 P 1309	77699	119
1T15M-6	9 10-16 P 500	64317	116
1T15M-6	9 10-16 P 392	64305	112
1T15M-6	9 10-16 P 352	64297	110

**Firestone bellows CT**

1T15M-6	9 10-16 P 394	64307	113
1T15M-6	9 10-16 A 354	64299	110
1T15M-6	9 10-16 P 372	64301	111
1T15M-6	9 10-16 P 410	64276	114
1T15M-6	9 10-17.5 P 731 (BK)	64668	135
1T15M-6	9 10-16 P 391	64304	112
1T15M-6	9 10-16 P 353	64298	110
1T15M-6	9 10-16 P 332	64293	109
1T15M-6	9 10-16 P 416 (BK)	69643	114
1T15M-6	9 10-16 P 498	64315	115
1T15M-6	9 10-16 P 408	64259	113
1T15M-7.5	9 10-17.5 A 535	64411	133
1T15M-7.5	9 10-17.5 P 426	64398	128
1T15M-7.5	9 10-17.5 P 475	64407	132
1T15M-7.5	9 10-17.5 P 023	68158	126
1T15M-7.5	9 10-17.5 P 732 (BK)	64669	135
1T15M-7.5	9 10-17.5 P 443	64402	130
1T15M-7.5	9 10-17.5 P 548	64412	133
1T15M-7.5	9 10-17.5 P 429	64278	129
1T15M-7.5	9 10-17.5 P 904	66700	138
1T15M-7.5	9 10-17.5 P 454	64405	131
1T15M-7.5	9 10-17.5 P 418	64334	128
1T15M-7.5	9 10-17.5 A 930	67586	138
1T15M-7.5	9 10-17.5 P 452	64404	131
1T15M-7.5	9 10-17.5 P 430	64400	129
1T15M-7.5	9 10-17.5 P 428	64399	129
1T15M-8	9 10-18.5 P 097	68614	143
1T15M-8	9 10-18.5 P 519 (BK)	64265	144
1T15M-8	9 10-18.5 P 935 (BK)	66978	146
1T15M-8	9 10-18.5 P 551	64414	145
1T15M-8	9 10-18.5 P 096 (BK)	68613	143
1T15M-8	9 10-18.5 P 1322	77861	147
1T15M-8	9 10-18.5 P 939 (BK)	67573	146
1T15M-8	9 10-18.5 P 095 (BK)	68612	142
1T15M-8	9 10-18.5 P 521 (BK)	69646	145
1T15M-8	9 10-18.5 P 406 (BK)	68615	144
1T15M-9	9 10-19 P 321	64280	150
1T15M-9	9 10-19 P 356	64325	151
1T15M-9	9 10-19 P 358	64615	152
1T15M-9	9 10-19 P 439	65356	154
1T15M-9	9 10-19 P 326	64323	150
1T15M-9	9 10-19 P 552	64340	155
1T15M-9	9 10-19 P 472	64339	155

**Firestone bellows CT**

1T15M-9	9 10-19 P 315	64279	150
1T15M-9	9 10-19 P 383	64281	153
1T15M-9	9 10-19 P 553	64341	156
1T15M-9	9 10-19 P 762	64708	156
1T15M-9	9 10-19 P 355	64324	151
1T15M-9	9 10-19 P 438	64335	154
1T15M-9	9 10-19 P 765	64711	156
1T15M-9	9 10-19 P 470	64338	154
1T15M-9	9 10-19 P 1138	74663	160
1T15M-9	9 10-19 P 898	66666	158
1T15M-9	9 10-19 P 359	64328	152
1T15M-9	9 10-19 P 357	64326	151
1T15M-9	9 10-19 P 390	64331	153
1T15MBTW-10	9 10BP-20 P 738	64694	162
1T15MBTW-12	9 10BP-22 P 739	64695	167
1T15MBTW-6	9 10BP-16 P 569	64693	120
1T15MLW-7	9 10-17.5 P 436	64401	130
1T15MM-9	9 10-19 P 435	64288	153
1T15MPW-7	9 10-17.5 P 831	65831	137
1T15MPW-7	9 10-17.5 P 1388	78601	139
1T15MPW-7	9 10-17.5 P 536	64423	133
1T15MT-3	9 10-13.5 P 232	69800	88
1T15MT-3	9 10-14 P 575	65361	101
1T15MT-3	9 10-12 A 427	64395	81
1T15MT-6	9 10-16 P 549 (BK)	69658	117
1T15MT-8	9 10-18.5 P 550 (BK)	69659	145
1T15MW-6	9 10-16 P 710	64634	117
1T15T-1	9 9-12 P 1292	77432	55
1T15T-1	9 9-12 P 705	64627	52
1T15TM-1	9 9-12 P 1476	79614	55
1T15TQ-1	9 9L-10 P 1150	74843	47
1T15V-1	9 10-10 S 221	69767	70
1T15V-11	9 10D-21 A 363	64376	167
1T15V-11	9 10D-21 A 555	64377	167
1T15V-11	9 10D-21 A 324	64375	166
1T15V-8	9 10-17.5 P 502 (BK)	69648	132
1T15V-8	9 10-17.5 P 571	64415	134
1T15V-8	9 10B-17.5 A 362	65359	140
1T15V-8	9 10-17.5 P 445 (BK)	69650	130
1T15V-8	9 10-17.5 P 574 (BK)	69654	135
1T15V-8	9 10B-17.5 A 323	64371	140
1T15V-8	9 10B-17.5 P 554 (BK)	69652	140
1T15V-8	9 10-17.5 P 467 (BK)	69649	131

Firestone bellows CT		No.	2 3
1T15VMR-8	9 10BS-17 P 1193 (BK)	77593	125
1T15VMR-8	9 10BS-17 P 1192 (BK)	75266	124
1T15VMR-8	9 10BS-17 P 1193	75267	124
1T15VMW-8	9 10-17.5 P 779	64729	136
1T15VP-4	9 10-13.5 S 433	64287	89
1T15VP-4	9 10-13.5 S 881	66447	90
1T15XBZR7.5	9 10S-16 A 382	64266	120
1T15XBZR7.5	9 10S-16 S 382	77614	121
1T15XBZR7.5	9 10S-16 P 382	67473	121
1T15XMR-7	9 10S-17 P 1154 (BK)	74884	126
1T15XNR-5	9 10S-16 P 1068 (BK)	73770	122
1T15XR-9	9 10S-18 P 1067 (BK)	73746	142
1T15XR-9	9 10S-18 P 1066 (BK)	73745	142
1T15ZR-6	9 10S-16 P 999	68208	122
1T17B-11	10 10-21 P 774	64728	183
1T17B-11	10 10-21 P 570	64252	183
1T17B-11	10 10-21 P 486	64419	182
1T17B-11	10 10-21 P 964	67624	184
1T17B-5	10 10-15 S 713	64639	173
1T17B-5	10 10-15 S 518	64396	172
1T17B-5	10 10-15 P 522	64397	173
1T17B-5	10 10-15 S 871	66340	174
1T17B-5	10 10-15 S 962	67600	174
1T17B-5	10 10-15 S 773	64725	174
1T17B-5	10 10-15 P 1140	74765	175
1T17B-5	10 10-15 P 453	64624	172
1T17BB-2	10 10.5C-13 P 1226	75741	184
1T17BV-3	10 10U-13 P 189	69494	169
1T17C-3	10 10-13 S 1614	601634	168
1T17C-6.5	10 10-16.5 S 262	70010	180
1T17CA-5	10 10.5-15 P 460	64645	185
1T17CA-6.5	10 10-16 P 526	64638	177
1T17CA-6.5	10 10-16 P 533	64636	177
1T17CD-3	10 10A-12 P 1330	77963	168
1T17CL-5	10 10-15 P 711	64635	173
1T17CL-9.5	10 10-21 P 434	64394	182
1T17CL-9.5	10 10-21 P 015	67951	181
1T19F-12	11 10.5-22 S 750	64688	210
1T19F-12	11 10.5-22 A 931	68159	211
1T19F-12	11 10.5-22 S 1009	70771	211
1T19F-5	11 10.5-15 A 1141	74766	190
1T19L-11	11 10.5-21 A 558	64356	207
1T19L-11	11 10.5-21 A 313	64273	206

Firestone bellows CT		No.	2 3
1T19L-11	11 10.5-21 A 370	64354	207
1T19L-11	11 10.5-19 A 960	67547	203
1T19L-11	11 10.5-21 A 318	64352	206
1T19L-11	11 10.5-21 A 025	68010	205
1T19L-11	11 10.5-21 A 1339	78046	208
1T19L-12	11 10.5-22 A 530	64422	209
1T19L-14	11 10.5-24 S 712	64637	213
1T19L-14	11 10.5-24 S 276	70118	212
1T19L-14	11 10.5-24 S 277	70119	213
1T19L-3	11 10.5-13 A 1132	74618	187
1T19L-5	11 10.5-15 A 414	64424	188
1T19L-5	11 10.5-15 A 422	64428	189
1T19L-5	11 10.5-15 A 506	64429	190
1T19L-5	11 10.5-15 A 420	64426	189
1T19L-5	11 10.5-15 A 415	64253	188
1T19L-5	11 10.5-15 A 421	64427	189
1T19L-5	11 10.5-15 A 419	64425	188
1T19L-7	11 10.5-17 A 364	64343	197
1T19L-7	11 10.5-17 A 368	65358	198
1T19L-7	11 10.5-17 A 317	64272	197
1T19L-7	11 10.5-17 A 388	64348	199
1T19L-7	11 10.5-17 A 507	64350	199
1T19L-7	11 10.5-17 A 367	64346	198
1T19L-7	11 10.5-17 A 377	64347	198
1T19L-7	11 10.5-17 A 208	69629	196
1T19L-7	11 10.5-17 A 316	64342	196
1T19L-7	11 10.5-17 A 365	64344	197
1T19L-7	11 10.5-17 A 556	64351	200
1T19L-7	11 10.5-17 A 405	64349	199
1T19L-9	11 10.5-19 A 432	64392	202
1T19L-9	11 10.5-19 A 509	64289	203
1T19L-9	11 10.5-19 A 431	64391	202
1T19L-9	11 10.5-19 A 557	65360	203
1T19L-9	11 10.5-19 A 508	64393	202
1T19LC-6	11 10.5A-16 P 523	64421	190
1T19LC-8	11 10.5B-18 P 743	65368	201
1T19LF-7	11 10.5F-17 P 745	65593	200
1T19ZK-5.7	11 10.5C-16 A 320	64254	191
1T19ZK-5.7	11 10.5C-16 A 378	64357	191
1T19ZK-5.7	11 10.5C-16 A 385	64359	192
1T19ZK-5.7	11 10.5C-16 A 380	64358	192
20	FD 200-19 506	64518	234
20	FD 200-19 362	64511	232



Firestone bellows CT		No.	2 3
20	FD 200-19 724	64712	236
20	FD 200-19 315	64510	231
20	FD 200-19 320	64267	232
20	FD 200-19 499	64515	233
20	FD 200-19 539	64520	235
20	FD 200-19 452	64514	233
20	FD 200-19 310	64509	231
20	FD 200-19 505	64517	234
20	FD 200-19 510	64519	235
20	FD 200-19 319	64271	231
20	FD 200-19 450	64513	233
20	FD 200-19 712	64685	235
20	FD 200-19 448	64512	232
20	FD 200-19 504	64516	234
20-1	FD 200-22 529	64558	239
20-1	FD 200-23A 709	64683	241
20-1	FD 200-22 706	64665	239
20-2	FD 200-25 429	64552	242
20-2	FD 200-25 511	64557	244
20-2	FD 200-25 426	64549	241
20-2	FD 200-25 427	64550	241
20-2	FD 200-25 454	64554	243
20-2	FD 200-25 507	64556	243
20-2	FD 200-25 721	64622	244
20-2	FD 200-25 453	64553	242
20-2	FD 200-25 428	64551	242
20-2	FD 200-25 463	64555	243
20F	FD 200-19 713	67705	236
20F	FD 200-22A 1062	78246	240
20F-2	FD 200-25 1008	75184	245
21	FD 530-22 321	64545	257
21	FD 530-22 374	64548	258
21	FD 530-22 316	64544	257
21	FD 530-22 345	64547	258
21	FD 530-22 342	64546	258
21	FD 530-22 311	64543	257
21-2	FD 530-30 518	64591	259
21-2	FD 530-30 532	64593	260
21-2	FD 530-30 449	64589	259
21-2	FD 530-30 519	64592	260
21-2	FD 530-30 451	64590	259
21D-2	FD 530-35 1165	77199	263
22	FD 330-22 343	64491	247

Firestone bellows CT		No.	2 3
22	FD 330-22 337	64490	247
22	FD 330-22 363	64493	248
22	FD 330-22 318	64488	246
22	FD 330-22 368	64498	250
22	FD 330-22 472	64500	250
22	FD 330-22 331	64268	246
22	FD 330-22 540	64502	251
22	FD 330-22 365	64495	249
22	FD 330-22 313	64270	245
22	FD 330-22 367	64497	249
22	FD 330-22 471	64499	250
22	FD 330-22 346	64492	248
22	FD 330-22 334	64489	247
22	FD 330-22 366	64496	249
22	FD 330-22 327	64283	246
22	FD 330-22 364	64494	248
22	FD 330-22 500	64501	251
22-1.5	FD 330-30 323	64531	252
22-1.5	FD 330-30 340	64532	252
22-1.5	FD 330-30 371	64535	253
22-1.5	FD 330-30 513	64541	255
22-1.5	FD 330-30 373	64537	254
22-1.5	FD 330-30 370	64534	253
22-1.5	FD 330-30 369	64533	252
22-1.5	FD 330-30 512	64540	254
22-1.5	FD 330-30 502	64539	254
22-1.5	FD 330-30 372	64536	253
224C	FD 110-15 758	65391	227
224C	FD 110-15 763	66092	227
228-1.5	FD 331-26 514	64597	256
228-1.5	FD 331-26 480	64284	256
228-1.5	FD 331-26 541	64599	256
233-2	FD 530-35 544	64606	261
233-2	FD 530-35 530	64604	261
233-2	FD 530-35 545	64607	262
233-2	FD 530-35 543	64605	261
255C-1.5	FD 70-15 738	64735	223
26	FD 120-20 715	64666	230
26	FD 120-20 509	64601	229
26	FD 110-17A 775	67667	228
26	FD 110-17A 789	67553	228
26C	FD 120-20 795	66661	230
313	FT 530-32 329	64504	276

Firestone bellows CT		No.	2 3
313	FT 530-32 536	64508	277
313	FT 530-32 325	64503	276
313	FT 530-32 336	64506	277
313	FT 530-32 535	64507	277
313	FT 530-32 333	64505	276
333	FT 530-35 456	64582	280
333	FT 530-35 521	64584	281
333	FT 530-35 726	65828	282
333	FT 530-35 438	64578	279
333	FT 530-35 523	64586	281
333	FT 530-35 455	64581	280
333	FT 530-35 534	64587	282
333	FT 530-35 437	64577	278
333	FT 530-35 457	64583	280
333	FT 530-35 441	64580	279
333	FT 530-35 436	64576	278
333	FT 530-35 537	64588	282
333	FT 530-35 439	64579	279
333	FT 530-35 522	64585	281
352D	FT 330-29 790	69747	273
354	FT 330-29 875	69641	274
354	FT 330-29 525	64571	269
354	FT 330-29 714	67904	271
354D	FT 330-29 554	66522	271
38	FT 330-29 469	64566	268
38	FT 330-29 430	64561	266
38	FT 330-29 546	64572	270
38	FT 330-29 432	64563	267
38	FT 330-29 520	64570	269
38	FT 330-29 548	64574	270
38	FT 330-29 434	64285	267
38	FT 330-29 498	64567	268
38	FT 330-29 413	64560	266
38	FT 330-29 433	64564	267
38	FT 330-29 874	69630	273
38	FT 330-29 466	64565	268
38	FT 330-29 547	64573	270
38	FT 330-29 723	64710	272
38	FT 330-29 431	64562	266
38D	FT 330-29 703	64648	271
5.25" ORANGE	SC29-O086	67858	293
6.5" BLUE	SC29-B152	67862	289
6.5" WHITE	SC29-W035	67851	297

Firestone bellows CT		No.	2 3
6.5" WHITE	SC31-W206	67452	306
6.75" ORANGE	SC29-O001	67770	290
6.75" WHITE	SC29-W087	67636	300
7.00" GREEN	SC29-O001	67770	290
7.25" ORANGE	SC29-O201	67766	295
7.5" ORANGE	SC29-O100	67637	293
7.5" ORANGE	SC29-O155	75314	294
7.75" WHITE	SC29-W103	67860	301
7.75" WHITE	SC29-W075	67859	300
7.75" YELLOW	SC29-Y108	67852	303
7.75" YELLOW	SC29-Y064	67768	302
7.87" YELLOW	SC29-Y109	69624	303
8" YELLOW	SC31-Y205	67638	306
8.0" WHITE	SC29-W061	67861	299
8.0" WHITE	SC29-W037	70017	298
8.25" YELLOW	SC29-Y082	67853	302
8.75" BLUE	SC29-B092	67854	288
9.25" ORANGE	SC29-O054	69923	291
9.62" ORANGE	SC29-O098	69924	293
C01-358-0583	9 10S-16 A 382	64266	120
C01-358-0583	9 10S-16 S 382	77614	121
C01-358-0583	9 10S-16 P 382	67473	121
IT14C1	6 6.5-11 S 048	68132	34
IT14C-1	6 6.5-11 S 052	68134	35
IT14C-1	6 6.5-11 S 028	68109	33
IT14C-1	6 6.5-11 S 030	68111	33
IT14C-1	6 6.5-11 S 032	68113	34
IT14C-1	6 6.5-11 S 051	68133	35
IT14C-1	6 6.5-11 S 031	68112	34
IT14C-1	6 6.5-11 S 029	68110	33
IT14C3	6 6.5-13 S 040	68122	39
IT14C3	6 6.5-13 S 043	68126	40
IT14C-3	6 6.5-13 S 559	68127	43
IT14C-3	6 6.5-13 S 056	68136	42
IT14C-3	6 6.5-13 S 038	68120	39
IT14C-3	6 6.5-13 S 045	68129	41
IT14C-3	6 6.5-13 S 041	68124	40
IT14C-3	6 6.5-13 S 047	68131	42
IT14C-3	6 6.5-13 S 039	68121	39
IT14C-3	6 6.5-13 S 044	68128	41
IT14C-3	6 6.5-13 S 446	68123	42
IT14C-3	6 6.5-13 S 046	68130	41
IT14CB-1	6 6.5B-11 S 035	68116	37

Firestone bellows		CT	No.	2 3
IT14CB-1	6 6.5D-11 S 037		68118	38
IT14CB-1	6 6.5B-11 S 054		68135	37
IT14CB-1	6 6.5D-11 S 525		68119	38
IT14CB-1	6 6.5D-11 S 034		68115	38

Goodyear	CT	No.	2 3
1B12-301	FS 330-11 468	64595	216
1B12-313	FS 330-11 474	64596	216
1B12-322	FS 330-11 467	64594	216
1B14-350	FS 530-14 442	64523	218
1B14-351	FS 530-14 447	64525	218
1B14-358	FS 530-14 339	64521	217
1R10-036	99M-13 P 1196	75412	58
1R10-089	99K-15 P 1147	74792	67
1R10-101	99L-10 P 1150	74843	47
1R10-105	99K-15 P 1299	77618	67
1R10-120	99K-15 P 424	64388	65
1R10-122	99K-15 P 425	64389	66
1R10-133	99K-15 P 1298	77616	67
1R11-018	99-14 P 322	64378	60
1R11-028	99-12 P 314	64255	48
1R11-039	99-14 A 337	64379	60
1R11-119	99M-13 P 1197	75410	58
1R11-121	99-14 P 1146	74791	63
1R11-149	99-12 P 464	64364	50
1R11-150	99-12 P 563	64286	52
1R11-159	99-12 P 479	64367	51
1R11-161	99-12 P 1476	79614	55
1R11-166	99K-15 P 417	64386	65
1R11-171	99-12 P 705	64627	52
1R11-178	99-14 P 895	67492	62
1R11-179	99-14 P 708	64631	61
1R11-191	99-14 P 517	64381	60
1R11-200	99-12 P 477	64365	50
1R11-201	99-12 P 478	64366	50
1R11-202	99-12 P 447	64363	49
1R11-203	99-12 P 479	64367	51
1R11-204	99-12 P 401	64362	49
1R11-205	99-12 P 516	64368	51
1R11-219	99-9 P 860 (BK)	69656	45
1R11-220	99-10 P 862 (BK)	69657	47
1R11-221	99-9 P 537 (BK)	68359	44
1R11-221	99-10 P 576 (BK)	68361	46
1R11-222	99-10 P 538 (BK)	68360	46
1R11-223	9 10-14 A 103	68620	91
1R11-225	99-12 P 1292	77432	55
1R11-232	9 10J-16 S 1551	600688	120
1R11-241	99-14 P 1308	77705	63
1R11-242	99-12 P 515	64256	51

Goodyear	CT	No.	2 3
1R11-252	9 10-17.5 P 536	64423	133
1R11-268	99-9 P 859 (BK)	68358	45
1R11-292	99-16 P 568	64692	68
1R11-893	6603 N P01	74916	44
1R11-915	99K-15 P 423	64387	65
1R12-028	99M-13 P 1181	75179	57
1R12-066	9 10-16 P 333	64294	109
1R12-069	9 10-14 P 312	64274	93
1R12-076	9 10-12 P 1145	74790	87
1R12-090	9 10-16 P 407	64262	113
1R12-092	9 10-16 P 310	64269	108
1R12-095	9 10-10 P 311	64260	70
1R12-1028	9 10-19 P 1251	76151	160
1R12-103	9 10-19 P 315	64279	150
1R12-1047	9 10-13.5 P 874	68151	89
1R12-1048	9 10-17.5 A 930	67586	138
1R12-1049	9 10S-17 P 1206	75561	126
1R12-1093	9 10-18.5 P 939 (BK)	67573	146
1R12-1094	9 10-12 P 543	64462	84
1R12-1095	9 10-14 P 882	66521	103
1R12-1179	9 10-14 A 959	601421	104
1R12-1204	9 10-14 P 577	65990	102
1R12-130	9 10-16 P 353	64298	110
1R12-132(0°Piston align)	9 10-12 A 341	64448	79
1R12-132(15°Piston align)	9 10-12 P 343	64450	80
1R12-132(45°Piston align)	9 10-12 P 319	64445	78
1R12-142	9 10-19 P 946	67479	159
1R12-142	9 10-19 A 946	67480	159
1R12-143	9 10-16 P 376	64302	111
1R12-145	9 10-19 P 356	64325	151
1R12-151	9 10-16 P 408	64259	113
1R12-152	9 10-12 P 319	64445	78
1R12-155	9 10-16 P 325	64292	108
1R12-156	99-12 P 1155	74911	55
1R12-165	9 10-12 P 343	64450	80
1R12-178	99-12 P 379	64361	49
1R12-182	9 10-16 P 408	64259	113
1R12-185	9 10-19 P 326	64323	150
1R12-188	9 10-16 P 409	64275	114
1R12-195	9 10-19 P 438	64335	154
1R12-205	9 10-14 P 450	64472	96
1R12-208	9 10-19 P 973	67703	159
1R12-220	9 10-16 P 372	64301	111

Goodyear	CT	No.	2 3	Goodyear	CT	No.	2 3
1R12-256	9 10-21 P 505	64384	164	1R12-436	9 10-16 P 497	64314	115
1R12-261	9 10-19 A 358	64327	152	1R12-437	9 10-14 A 496	64484	100
1R12-274	9 10-18.5 P 1183	75183	147	1R12-438	9 10-14 P 462	64474	97
1R12-275	9 10-19 P 357	64326	151	1R12-439	9 10-19 P 470	64338	154
1R12-279	9 10-19 P 383	64281	153	1R12-441	9 10-16 P 391	64304	112
1R12-281	9 10-19 P 321	64280	150	1R12-444	9 10-21 A 1332 (BK)	78074	165
1R12-281	9 10-19 P 383	64281	153	1R12-445	9 10-14 A 545	64486	101
1R12-285	9 10-14 P 709	64632	102	1R12-446	9 10-19 P 390	64331	153
1R12-303	9 10S-16 P 382	67473	121	1R12-450	9 10-17.5 P 418	64334	128
1R12-309	9 10-12 A 327	64446	79	1R12-467	9 10-19 A 830	65807	158
1R12-324	9 9-12 P 206	69627	48	1R12-467	9 10-19.5 A 801	65387	161
1R12-325	9 10-14 P 461	64473	97	1R12-480	9 10-19 P 1138	74663	160
1R12-335	9 10-21 A 361	64715	162	1R12-481	9 10-17.5 P 429	64278	129
1R12-350	9 10-10 P 339	64433	72	1R12-484	9 10-17.5 P 574 (BK)	69654	135
1R12-351	9 10-10 P 328	64430	71	1R12-485	9 10-17.5 P 572 (BK)	69662	134
1R12-352	9 10-14 P 345	64258	94	1R12-486	9 10-17.5 P 574 (BK)	69654	135
1R12-355	9 10-12 P 329	64447	79	1R12-487	9 10-12 P 488	64459	83
1R12-356	9 10-16 P 352	64297	110	1R12-492	9 10-14 A 545	64486	101
1R12-357	9 10-19 P 439	65356	154	1R12-494	9 10-17.5 A 802	64762	137
1R12-358	9 10-16 P 325	64292	108	1R12-498	9 10-17.5 P 428	64399	129
1R12-359	9 10-10 P 331	64431	71	1R12-499	9 10-17.5 P 454	64405	131
1R12-363	9 10-21 P 360	64382	162	1R12-502	9 10-17.5 P 443	64402	130
1R12-365	9 10-16 P 410	64276	114	1R12-504	9 10-17.5 P 502 (BK)	69648	132
1R12-366	9 10-17.5 P 436	64401	130	1R12-505	9 10-12 P 395	64451	80
1R12-366	9 10-16 P 710	64634	117	1R12-507	9 10AS-21 P 1280	77093	166
1R12-367	9 10-12 A 427	64395	81	1R12-508	9 10-12 P 484	64456	82
1R12-370	9 10-14 A 330	64464	93	1R12-509	9 10-16 A 310	70115	108
1R12-373	9 10B-17.5 P 554 (BK)	69652	140	1R12-512	9 10-12 A 707	64633	85
1R12-375	9 10-19 P 435	64288	153	1R12-512	9 10-12 P 707	69541	85
1R12-395	9 10-19 P 355	64324	151	1R12-523	9 10S-18 P 1066 (BK)	73745	142
1R12-400	9 10-16 P 416 (BK)	69643	114	1R12-532	9 10-17.5 P 548	64412	133
1R12-401	9 10-18.5 P 521 (BK)	69646	145	1R12-534	9 10-19 P 762	64708	156
1R12-402	9 10-18.5 P 935 (BK)	66978	146	1R12-538	9 10S-16 P 1068 (BK)	73770	122
1R12-403	9 10-18.5 P 519 (BK)	64265	144	1R12-541	9 10-16 P 769	64650	117
1R12-404	9 10-18.5 P 451 (BK)	68616	144	1R12-543	9 10-14 PT75 (BK)	64621	106
1R12-421	9 10-14 P 345	64258	94	1R12-552	9 10-17.5 P 572 (BK)	69662	134
1R12-422	9 10-12 A 104	68638	77	1R12-553	9 10B-17.5 P 554 (BK)	69652	140
1R12-423	9 10-16 P 1309	77699	119	1R12-554	9 10-17.5 P 571	64415	134
1R12-424	9 10-18.5 P 406 (BK)	68615	144	1R12-555	9 10-10 P 542	64658	75
1R12-432	9 10S-18 P 1067 (BK)	73746	142	1R12-556	9 10-10 P 480	64441	74
1R12-434	9 10-14 P 469	64477	98	1R12-557	9 10-10 P 503	64444	75
1R12-435	9 10-10 P 482	64443	75	1R12-558	9 10-10 P 400	64438	73
1R12-435	9 10-10 P 471	64439	73	1R12-559	9 10-10 P 399	64437	73

Goodyear	CT	No.	2 3
1R12-560	9 10-10 P 398	64436	72
1R12-561	9 10-10 P 397	64435	72
1R12-562	9 10-12 P 024	68009	77
1R12-563	9 10-12 P 544	64463	84
1R12-567	9 10-16 P 393	64306	112
1R12-568	9 10-19 P 472	64339	155
1R12-571	9 10-12 P 495	64460	84
1R12-576	9 10-16 P 770	64651	118
1R12-580	9 10-21 P 448	64383	163
1R12-584	9 10-16 P 1240	75973	119
1R12-586	9 10-17.5 P 445 (BK)	69650	130
1R12-599	9 10-21 P 1581	601035	166
1R12-603	9 10S-16 A 382	64266	120
1R12-607	9 10-19.5 P 801	600568	161
1R12-609	9 10-21 P 817	65649	164
1R12-613	9 10-19 P 552	64340	155
1R12-614	9 10-13.5 P 1394	78638	90
1R12-615	9 10S-17 P 1154 (BK)	74884	126
1R12-617	9 10-17.5 A 1205	75562	139
1R12-620	9 10-14 P 465 (BK)	69644	97
1R12-621	9 10-16 P 332	64293	109
1R12-622	9 10S-17 P 1152 (BK)	74882	125
1R12-629	9 10S-17 P 1153 (BK)	74883	125
1R12-636	9 10-14 P 575	65361	101
1R12-637	9 10-21 P 511	64385	164
1R12-639	9 10-19 P 357	64326	151
1R12-640	9 10-17.5 P 426	64398	128
1R12-644	9 10-19 P 552	64340	155
1R12-647	9 10S-17 P 1153 (BK)	74883	125
1R12-648	9 10-14 P 490	64479	98
1R12-653	9 10-21 A 1187	75221	165
1R12-654	9 10S-17 P 1206	75561	126
1R12-663	9 10-21 P 360	64382	162
1R12-669	9 10-14 A 312	75626	92
1R12-676	9 10-14 P 312	64274	93
1R12-689	9 10S-18 P 1067 (BK)	73746	142
1R12-843	6602 N P02	74915	43
1R13-038	11 10.5-21 A 313	64273	206
1R13-039	10 10-16.5 S 783	64746	180
1R13-047	11 10.5-17 A 377	64347	198
1R13-053	10 10-15 P 1140	74765	175
1R13-075	10 10-15 S 1015	72729	175
1R13-087	10 10-15 S 962	67600	174

Goodyear	CT	No.	2 3
1R13-097	10 10-15 S 962	67600	174
1R13-109	10 10-15 S 871	66340	174
1R13-115	9 10D-21 A 324	64375	166
1R13-116	9 10D-21 A 363	64376	167
1R13-117	9 10B-17.5 A 323	64371	140
1R13-118	10 10-21 P 434	64394	182
1R13-119	9 10-13.5 S 433	64287	89
1R13-120	11 10.5-15 A 422	64428	189
1R13-124	10 10-15 P 522	64397	173
1R13-124	10 10-15 P 711	64635	173
1R13-130	10 10A-12 P 1330	77963	168
1R13-138	10 10-15 S 518	64396	172
1R13-139	11 10.5-13 A 1132	74618	187
1R13-149	10 10-21 P 434	64394	182
1R13-152	10 10-21 P 570	64252	183
1R13-153	10 10-21 P 486	64419	182
1R13-155	10 10-16 S 724	64649	178
1R13-159	10 10.5-15 P 460	64645	185
1R13-171	10 10.5V-22 S 1179	75268	186
1R13-172	10 10.5V-24 S 1060	73913	186
1R13-176	10 10-16 P 533	64636	177
1R13-177	10 10-16 P 526	64638	177
1R13-181	10 10-16 S 1239	75972	178
1R13-188	10 10.5AV-16 P 1219	78239	185
1R13-189	10 10.5AV-16 P 1222	78238	186
1R13-207	10 10-15 S 713	64639	173
1R13-208	10 10-21 P 774	64728	183
1R13-210	10 10-15 S 773	64725	174
1R13-235	10 10.5V-24 S 1060	73913	186
1R13-237	10 10.5V-22 S 1179	75268	186
1R13-239	9 10-13.5 S 881	66447	90
1R14-018	11 10.5-17 A 365	64344	197
1R14-019	11 10.5-21 A 370	64354	207
1R14-026	11 10.5-17 A 364	64343	197
1R14-028	11 10.5-17 A 316	64342	196
1R14-030	11 10.5-21 A 318	64352	206
1R14-037	11 10.5-15 A 414	64424	188
1R14-038	11 10.5-15 A 415	64253	188
1R14-039	11 10.5C-16 A 320	64254	191
1R14-042	11 10.5C-16 A 378	64357	191
1R14-045	11 10.5-21 A 313	64273	206
1R14-068	11 10.5-15 A 415	64253	188
1R14-094	11 10.5C-16 A 380	64358	192



Goodyear	CT	No.	2 3
1R14-113	11 10.5-22 S 750	64688	210
1R14-115	11 10.5-17 A 367	64346	198
1R14-127	11 10.5-24 S 712	64637	213
1R14-130	11 10.5-17 A 507	64350	199
1R14-137	11 10.5-19 A 431	64391	202
1R14-148	11 10.5-24 S 1200	75464	213
1R14-149	11 10.5-22 S 1199	75465	212
1R14-151	11 10.5-19 A 960	67547	203
1R14-152	11 10.5D-21 S 1063	75269	209
1R14-154	11 10.5-21 A 062	68589	205
1R14-155	11 10.5C-16 A 729	64660	193
1R14-159	11 10.5-17 A 405	64349	199
1R14-160	11 10.5-17 A 377	64347	198
1R14-170	11 10.5-22 A 752	64690	210
1R14-171	11 10.5A-16 P 523	64421	190
1R14-172	11 10.5F-17 P 745	65593	200
1R14-174	11 10.5-22 A 530	64422	209
1R14-190	11 10.5F-17 P 745	65593	200
1R14-198	11 10.5C-16 A 706	64628	192
1R14-201	11 10.5-21 A 965	67625	208
1R14-209	11 10.5-19 A 1069	73833	204
1R14-232	11 10.5E-19 S 1320	77833	205
1R14-234	11 10.5-19 A 1250	76150	204
1R14-236	11 10.5-24 S 1200	75464	213
1R14-240	11 10.5-22 S 1199	75465	212
1R9-003	6 6.5-13 S 056	68136	42
1R9-038	6 6.5-13 S 039	68121	39
1R9-065	6 6.5B-11 S 027	68108	37
1R9-065	6 6.5D-11 S 525	68119	38
1R9-070	6 6.5-13 S 446	68123	42
1S3-013	SK 37-6 P02	74324	307
1S4.5-107	SC29-R080	78412	297
1S4.5-113	SC29-W056	69930	299
1S4.5-121	SC29-W035	67851	297
1S4-007	SC29-OG05	73607	295
1S4-035	SC29-O055	69926	292
1S4-044	SC29-OG13	78379	295
1S4-058	SC29-O086	67858	293
1S4-067	SC29-R007	70014	296
1S4-074	SC31-OG11	78422	305
1S4-173	SC29-PG09	78418	296
1S4-234	SC29-O132	75315	294
1S5-010	SC29-YG01	67882	304

Goodyear	CT	No.	2 3
1S5-040	SC29-W087	67636	300
1S5-045	SC29-YG02	70825	304
1S5-057	SC29-Y108	67852	303
1S5-070	SC31-BG12	78423	305
1S5-133	SC29-YG14	78410	304
1S5-152	SC29-B110	69437	288
1S5-154	SC29-BG07	78405	289
1S5-157	SC29-Y064	67768	302
1S5-164	SC29-BG08	78417	290
1S5-171	SC31-BG10	78421	305
1S5-175	SC31-Y215	68161	306
1S5-176	SC31-W206	67452	306
1S5-186	SC29-Y036	68162	301
1S5-190	SC29-B093	75313	288
2B10-226	FD 200-19 713	67705	236
2B12-300	FD 330-22 327	64283	246
2B12-304	FD 330-22 500	64501	251
2B12-305	FD 330-30 323	64531	252
2B12-307	FD 330-22 318	64488	246
2B12-309	FD 330-22 313	64270	245
2B12-313	FD 330-22 364	64494	248
2B12-317	FD 330-30 502	64539	254
2B12-319	FD 330-22 367	64497	249
2B12-320	FD 330-22 334	64489	247
2B12-324	FD 330-30 340	64532	252
2B12-324	FD 330-30 513	64541	255
2B12-345	FD 331-26 514	64597	256
2B12-346	FD 331-26 541	64599	256
2B12-402	FD 330-30 370	64534	253
2B12-406	FD 330-22 331	64268	246
2B12-410	FD 330-22 346	64492	248
2B12-411	FD 330-22 472	64500	250
2B12-412	FD 330-22 471	64499	250
2B12-416	FD 330-30 369	64533	252
2B12-425	FD 330-22 363	64493	248

Goodyear	CT	No.	2 3
2B12-426	FD 330-22 365	64495	249
2B12-427	FD 330-22 343	64491	247
2B12-428	FD 330-30 372	64536	253
2B12-429	FD 330-22 780	66300	251
2B12-432	FD 330-22 368	64498	250
2B12-434	FD 330-30 371	64535	253
2B12-440	FD 331-26 480	64284	256
2B12-446	FD 330-30 369	64533	252
2B12-463	FD 330-22 540	64502	251
2B14-354	FD 530-22 374	64548	258
2B14-355	FD 530-22 342	64546	258
2B14-356	FD 530-22 321	64545	257
2B14-359	FD 530-22 316	64544	257
2B14-360	FD 530-22 311	64543	257
2B14-362	FD 530-30 518	64591	259
2B14-363	FD 530-35 1165	77199	263
2B14-365	FD 530-30 451	64590	259
2B14-366	FD 530-30 449	64589	259
2B14-367	FD 530-22 345	64547	258
2B14-383	FD 530-35 530	64604	261
2B14-385	FD 530-35 1316	600554	263
2B14-462	FD 530-30 532	64593	260
2B14-470	FD 530-35 544	64606	261
2B14-476	FD 530-35 543	64605	261
2B6-535	FD 110-15 766	66094	228
2B7-548	FD 110-17A 775	67667	228
2B8-550	FD 120-20 509	64601	229
2B9-200	FD 200-19 320	64267	232
2B9-201	FD 200-19 499	64515	233
2B9-206	FD 200-19 315	64510	231
2B9-210	FD 200-19 362	64511	232
2B9-216	FD 200-19 319	64271	231
2B9-218	FD 200-25 453	64553	242
2B9-229	FD 200-19 505	64517	234
2B9-229	FD 200-22 706	64665	239
2B9-230	FD 200-19 450	64513	233
2B9-239	FD 200-19 310	64509	231
2B9-245	FD 200-19 510	64519	235
2B9-246	FD 200-19 452	64514	233
2B9-250	FD 200-25 426	64549	241
2B9-251	FD 200-25 429	64552	242
2B9-252	FD 200-25 454	64554	243
2B9-253	FD 200-25 427	64550	241

Goodyear	CT	No.	2 3
2B9-254	FD 200-25 463	64555	243
2B9-255	FD 200-25 428	64551	242
2B9-265	FD 200-19 448	64512	232
2B9-266	FD 200-25 454	64554	243
2B9-270	FD 200-25 721	64622	244
2B9-280	FD 200-19 448	64512	232
2B9-283	FD 200-22 529	64558	239
2B9-288	FD 200-19 504	64516	234
2B9-296	FD 200-19 1148	77120	238
2B9-495	FD 200-23A 709	64683	241
2B9-606	FD 200-19 539	64520	235
2B9-607	FD 200-25 511	64557	244
2B9-611	FD 200-19 895	70659	237
2B9-614	FD 200-19 894	70658	237
3B12-300	FT 330-29 431	64562	266
3B12-301	FT 330-29 498	64567	268
3B12-303	FT 330-29 434	64285	267
3B12-304	FT 330-29 503	64568	269
3B12-310	FT 330-29 466	64565	268
3B12-312	FT 330-29 525	64571	269
3B12-315	FT 330-29 547	64573	270
3B12-319	FT 330-29 413	64560	266
3B12-322	FT 330-29 790	69747	273
3B12-323	FT 430-35 1188	78687	275
3B12-324	FT 330-29 703	64648	271
3B12-326	FT 430-35 1178	77340	274
3B12-328	FT 330-29 546	64572	270
3B12-329	FT 330-29 703	64648	271
3B12-335	FT 330-29 520	64570	269
3B12-335	FT 330-29 723	64710	272
3B12-337	FT 430-35 1298	601025	275
3B12-338	FT 330-29 1007	75142	274
3B12-339	FT 430-35 1314	600720	275
3B12-415	FT 330-29 554	66522	271
3B12-416	FT 330-29 875	69641	274
3B14-354	FT 530-32 336	64506	277
3B14-356	FT 530-32 329	64504	276
3B14-359	FT 530-32 325	64503	276
3B14-360	FT 530-32 333	64505	276
3B14-364	FT 530-35 455	64581	280
3B14-367	FT 530-35 457	64583	280
3B14-450	FT 530-35 521	64584	281
3B14-451	FT 530-35 456	64582	280



Goodyear	CT	 No.	 2 3
3B14-452	FT 530-35 441	64580	279
3B14-453	FT 530-35 436	64576	278
3B14-456	FT 530-35 437	64577	278
3B14-457	FT 530-35 455	64581	280
3B14-459	FT 530-35 457	64583	280
3B14-460	FT 530-35 439	64579	279
3B14-462	FT 530-35 522	64585	281
3B14-463	FT 530-35 523	64586	281
3B14-464	FT 530-35 534	64587	282
8015	6S 9.5-13	70129	32
8017	5S 8-15.5 (644N)	66141	32
8018	6S 9.5-15.5 (661 N)	68461	32

Goodyear bellows	CT	No.	2 3
556038015	6S 9.5-13	70129	32
556038018	6S 9.5-15.5 (661 N)	68461	32
556338335	FT 530-35 521	64584	281
556338335	FT 530-35 441	64580	279
566183003	6 6.5B-11 S 027	68108	37
566183003	6 6.5D-11 S 525	68119	38
566183004	6 6.5-13 S 056	68136	42
566183004	6 6.5-13 S 446	68123	42
566183010	6 6.5-13 S 039	68121	39
566203021	9 9K-15 P 1298	77616	67
566203021	9 9K-15 P 1299	77618	67
566203021	9 9K-15 P 424	64388	65
566203021	9 9K-15 P 1147	74792	67
566203027	9 9L-10 P 1150	74843	47
566207106	10 10-15 S 773	64725	174
566223006	9 9-14 P 322	64378	60
566223021	9 9-10 P 538 (BK)	68360	46
566223021	9 9-12 P 515	64256	51
566223021	9 9-10 P 862 (BK)	69657	47
566223021	9 9-12 P 447	64363	49
566223021	9 9-9 P 859 (BK)	68358	45
566223021	9 9-12 P 563	64286	52
566223021	9 9-9 P 537 (BK)	68359	44
566223021	9 9-12 P 477	64365	50
566223021	9 9-12 P 516	64368	51
566223021	9 9-12 P 401	64362	49
566223021	9 9-12 P 479	64367	51
566223021	9 9-12 P 478	64366	50
566223021	9 9-10 P 576 (BK)	68361	46
566223021	9 9-14 P 1308	77705	63
566223021	9 9-9 P 860 (BK)	69656	45
566223042	9 10-17.5 P 536	64423	133
566223057	9 9-12 P 1292	77432	55
566223057	9 9-12 P 705	64627	52
566 22 3 057	9 9-12 P 1476	79614	55
566-22-3-095	9 9-16 P 568	64692	68
566223143	9 9-14 P 708	64631	61
566223143	9 9K-15 P 417	64386	65
566223143	9 10-14 A 103	68620	91
566223143	9 9-14 A 337	64379	60
566223143	9 9-14 P 1146	74791	63
566223143	9 9-14 P 517	64381	60
566223143	9 9-12 P 464	64364	50

Goodyear bellows	CT	No.	2 3
566223143	9 9-14 P 895	67492	62
566223143	9 10J-16 S 1551	600688	120
566223578	6603 N P01	74916	44
566243021	9 9-12 P 314	64255	48
566243024	9 9M-13 P 1181	75179	57
566243038	9 10-17.5 P 571	64415	134
566243038	9 10-17.5 P 436	64401	130
566243038	9 10-16 P 310	64269	108
566243038	9 10-16 P 393	64306	112
566243038	9 10-17.5 P 426	64398	128
566243038	9 10-17.5 A 802	64762	137
566243038	9 10-16 P 407	64262	113
566243038	9 10-16 P 497	64314	115
566243038	9 10-16 P 769	64650	117
566243038	9 10-16 P 325	64292	108
566243038	9 10-16 P 409	64275	114
566243038	9 10-14 P 312	64274	93
566243038	9 10-17.5 P 443	64402	130
566243038	9 10-16 P 333	64294	109
566243038	9 10-16 P 1309	77699	119
566243038	9 10-17.5 P 445 (BK)	69650	130
566243038	9 10-17.5 P 454	64405	131
566243038	9 10-17.5 P 574 (BK)	69654	135
566243038	9 10-14 P 462	64474	97
566243038	9 10-16 P 352	64297	110
566243038	9 10-16 P 710	64634	117
566243038	9 10-16 P 372	64301	111
566243038	9 10-14 P 709	64632	102
566243038	9 10B-17.5 P 554 (BK)	69652	140
566243038	9 10-16 P 410	64276	114
566243038	9 10-16 P 391	64304	112
566243038	9 10-17.5 P 572 (BK)	69662	134
566243038	9 10-16 P 770	64651	118
566243038	9 10-16 P 353	64298	110
566243038	9 10-16 P 416 (BK)	69643	114
566243038	9 10-16 A 310	70115	108
566243038	9 10-16 P 408	64259	113
566-24-3-038	9 10-14 A 312	75626	92
566-24-3-038	9 10-16 P 1240	75973	119
566243048	9 10-16 P 376	64302	111
566243061	9 10-10 P 339	64433	72
566243061	9 10-10 P 328	64430	71
566243061	9 10-10 P 331	64431	71

**Goodyear bellows CT**

566243066	9 10-19 A 830	65807	158
566243066	9 10-17.5 P 502 (BK)	69648	132
566243066	9 10-19 P 321	64280	150
566243066	9 10-19 P 435	64288	153
566243066	9 10-19 P 356	64325	151
566243066	9 10-19 P 946	67479	159
566243066	9 10-21 A 1187	75221	165
566243066	9 10-19 P 439	65356	154
566243066	9 10-19.5 P 801	600568	161
566243066	9 10-19 P 326	64323	150
566243066	9 10-19 P 552	64340	155
566243066	9 10-19 P 472	64339	155
566243066	9 10-19 P 315	64279	150
566243066	9 10-19 P 383	64281	153
566243066	9 10-19 P 355	64324	151
566243066	9 10-19 P 438	64335	154
566243066	9 10-19 A 358	64327	152
566243066	9 10-19 A 946	67480	159
566243066	9 10-19 P 973	67703	159
566243066	9 10-19 P 470	64338	154
566243066	9 10-19 P 1138	74663	160
566243066	9 10-19.5 A 801	65387	161
566243066	9 10-19 P 357	64326	151
566243066	9 10-21 A 1332 (BK)	78074	165
566243067	9 10-12 P 484	64456	82
566243067	9 10-12 A 327	64446	79
566243067	9 10-12 P 488	64459	83
566243067	9 10-10 P 480	64441	74
566243067	9 10-10 P 399	64437	73
566243067	9 9-12 P 206	69627	48
566243067	9 10-10 P 311	64260	70
566243067	9 10-10 P 398	64436	72
566243067	9 10-10 P 482	64443	75
566243067	9 10-10 P 471	64439	73
566243067	9 10-12 P 544	64463	84
566243067	9 9-12 P 379	64361	49
566243067	9 10-10 P 542	64658	75
566243067	9 9-12 P 1155	74911	55
566243067	9 10-10 P 473	64440	74
566243067	9 10-12 P 024	68009	77
566243067	9 10-10 P 400	64438	73
566243067	9 10-10 P 503	64444	75
566243067	9 10-12 P 495	64460	84

**Goodyear bellows CT**

566243076	9 10-12 A 707	64633	85
566243076	9 10-12 P 319	64445	78
566243076	9 10-14 P 345	64258	94
566243076	9 10-12 P 707	69541	85
566243076	9 10-14 P 465 (BK)	69644	97
566243076	9 10-14 P 575	65361	101
566243076	9 10-12 P 395	64451	80
566243076	9 10-12 A 104	68638	77
566243076	9 10-14 P 461	64473	97
566243076	9 10-14 PT75 (BK)	64621	106
566243076	9 10-14 P 469	64477	98
566243076	9 10-12 P 329	64447	79
566243076	9 10-12 A 427	64395	81
566243076	9 10-13.5 P 1394	78638	90
566243076	9 10-12 P 1145	74790	87
566243076	9 10-14 P 490	64479	98
566243076	9 10-14 A 496	64484	100
566243076	9 10-14 A 330	64464	93
566243076	9 10-14 P 450	64472	96
566243090	9 10-21 P 505	64384	164
566243090	9 10-21 P 817	65649	164
566243090	9 10-21 P 360	64382	162
566243090	9 10-21 P 511	64385	164
566243090	9 10-21 A 361	64715	162
566-24-3-090	9 10-21 P 1581	601035	166
566-24-3-090	9 10AS-21 P 1280	77093	166
566243097	9 10-18.5 P 935 (BK)	66978	146
566243097	9 10S-17 P 1206	75561	126
566243097	9 10-18.5 P 451 (BK)	68616	144
566243097	9 10-17.5 P 548	64412	133
566243097	9 10S-17 P 1153 (BK)	74883	125
566243097	9 10-17.5 P 429	64278	129
566243097	9 10-19 P 552	64340	155
566243097	9 10S-17 P 1152 (BK)	74882	125
566243097	9 10-17.5 P 418	64334	128
566243097	9 10-17.5 A 930	67586	138
566243097	9 10-17.5 P 428	64399	129
566243097	9 10-16 P 332	64293	109
566243097	9 10-18.5 P 1183	75183	147
566243097	9 10-19 P 390	64331	153
566243097	9 10-18.5 P 406 (BK)	68615	144
566243108	9 10S-16 A 382	64266	120
566243108	9 10S-16 P 382	67473	121

Goodyear bellows	CT	No.	2 3
566243116	9 10-19 P 762	64708	156
566-24-3-116	9 10-19 P 1251	76151	160
566243117	9 10-21 P 448	64383	163
566243140	9 10-18.5 P 519 (BK)	64265	144
566243142	9 10-13.5 P 874	68151	89
566-24-3-161	9 10-12 P 543	64462	84
566243163	9 10S-16 P 1068 (BK)	73770	122
566243163	9 10-18.5 P 521 (BK)	69646	145
566243164	9 10S-17 P 1154 (BK)	74884	126
566243165	9 10S-18 P 1067 (BK)	73746	142
566243165	9 10S-18 P 1066 (BK)	73745	142
566-24-3-170	9 10-18.5 P 939 (BK)	67573	146
566-24-3-171	9 10-14 P 882	66521	103
566-24-3-172	9 10-19 P 898	66666	158
566-24-3-289	9 10-14 P 577	65990	102
566243548	6602 N P02	74915	43
566263015	11 10.5C-16 A 729	64660	193
566263043	9 10B-17.5 A 323	64371	140
566263044	9 10D-21 A 363	64376	167
566263044	9 10D-21 A 324	64375	166
566263050	10 10-15 S 518	64396	172
566263050	10 10-15 P 522	64397	173
566263050	10 10-15 P 711	64635	173
566263051	10 10-15 S 1015	72729	175
566263051	11 10.5-17 A 377	64347	198
566263051	10 10-16 S 724	64649	178
566263051	10 10-15 P 1140	74765	175
566263051	10 10-16.5 S 783	64746	180
566-26-3-051	10 10-16 S 1239	75972	178
566263053	9 10-13.5 S 433	64287	89
566263053	9 10-13.5 S 881	66447	90
566263054	11 10.5-15 A 422	64428	189
566263055	10 10A-12 P 1330	77963	168
566263068	10 10-21 P 434	64394	182
566263071	10 10-21 P 774	64728	183
566263071	10 10-21 P 570	64252	183
566263071	10 10-21 P 486	64419	182
566263072	11 10.5-21 A 313	64273	206
566263073	10 10.5-15 P 460	64645	185
566263078	10 10-16 P 526	64638	177
566263078	10 10-16 P 533	64636	177
566263078	10 10.5AV-16 P 1222	78238	186
566263078	10 10.5AV-16 P 1219	78239	185

Goodyear bellows	CT	No.	2 3
566263081	10 10-15 S 713	64639	173
566263081	10 10-15 S 871	66340	174
566263081	10 10-15 S 962	67600	174
566263097	10 10.5V-22 S 1179	75268	186
566283015	11 10.5-15 A 414	64424	188
566283015	11 10.5C-16 A 378	64357	191
566283015	11 10.5C-16 A 706	64628	192
566283015	11 10.5-15 A 415	64253	188
566283015	11 10.5C-16 A 380	64358	192
566283020	11 10.5-21 A 965	67625	208
566283020	11 10.5-22 A 530	64422	209
566283020	11 10.5-21 A 313	64273	206
566283020	11 10.5-21 A 370	64354	207
566283020	11 10.5-19 A 1069	73833	204
566283020	11 10.5-21 A 062	68589	205
566283020	11 10.5-19 A 960	67547	203
566283020	11 10.5-21 A 318	64352	206
566283020	11 10.5-22 A 752	64690	210
566283021	11 10.5-17 A 364	64343	197
566283021	11 10.5-17 A 367	64346	198
566283021	11 10.5-17 A 377	64347	198
566283021	11 10.5-19 A 431	64391	202
566283021	11 10.5-17 A 316	64342	196
566283021	11 10.5-17 A 365	64344	197
566283021	11 10.5-17 A 405	64349	199
566-28-3-021	11 10.5-19 A 1250	76150	204
566283030	11 10.5-22 S 750	64688	210
566283031	11 10.5-24 S 712	64637	213
566283042	11 10.5F-17 P 745	65593	200
566283042	11 10.5E-19 S 1320	77833	205
566283044	11 10.5F-17.5 P 800	65218	200
566283044	11 10.5F-17 P 745	65593	200
566283057	11 10.5-24 S 1200	75464	213
566283059	11 10.5-22 S 1199	75465	212
566283065	11 10.5C-16 A 320	64254	191
566283065	11 10.5A-16 P 523	64421	190
566338335	FT 530-35 455	64581	280
566338335	FT 530-35 534	64587	282
566338335	FT 530-35 457	64583	280
566923356	FD 530-30 518	64591	259
578338335	FT 530-35 523	64586	281
578338335	FT 530-35 437	64577	278
578338335	FT 530-35 436	64576	278

**Goodyear bellows CT**

578338335	FT 530-35 522	64585	281
578913301	FS 330-11 474	64596	216
578913301	FS 330-11 468	64595	216
578913301	FS 330-11 467	64594	216
578913351	FS 530-14 447	64525	218
578913351	FS 530-14 442	64523	218
578913352	FS 530-14 339	64521	217
57892306	FD 200-25 721	64622	244
578923202	FD 200-19 362	64511	232
578923202	FD 200-19 315	64510	231
578923202	FD 200-19 320	64267	232
578923202	FD 200-19 499	64515	233
578923202	FD 200-19 510	64519	235
578923202	FD 200-19 319	64271	231
578923202	FD 200-19 450	64513	233
578923206	FD 200-25 429	64552	242
578923206	FD 200-25 511	64557	244
578923206	FD 200-25 426	64549	241
578923206	FD 200-25 427	64550	241
578923206	FD 200-25 454	64554	243
578923206	FD 200-25 453	64553	242
578923206	FD 200-19 448	64512	232
578923206	FD 200-25 428	64551	242
578923206	FD 200-25 463	64555	243
578923208	FD 200-25 454	64554	243
578-923-211	FD 200-19 1148	77120	238
578923211	FD 200-19 539	64520	235
578923211	FD 200-19 452	64514	233
578923211	FD 200-19 310	64509	231
578923211	FD 200-19 505	64517	234
578923211	FD 200-22 706	64665	239
578923211	FD 200-19 448	64512	232
578923211	FD 200-19 504	64516	234
578-92-3-217	FD 200-23A 709	64683	241
578923250	FD 200-19 713	67705	236
578923309	FD 330-22 343	64491	247
578923309	FD 330-22 363	64493	248
578923309	FD 330-22 318	64488	246
578923309	FD 330-22 368	64498	250
578923309	FD 330-22 472	64500	250
578923309	FD 330-22 331	64268	246
578923309	FD 330-22 540	64502	251
578923309	FD 330-22 365	64495	249

**Goodyear bellows CT**

578923309	FD 330-22 313	64270	245
578923309	FD 330-22 367	64497	249
578923309	FD 330-22 471	64499	250
578923309	FD 330-22 780	66300	251
578923309	FD 330-22 346	64492	248
578923309	FD 330-22 334	64489	247
578923309	FD 330-22 327	64283	246
578923309	FD 330-22 364	64494	248
578923309	FD 330-22 500	64501	251
578923310	FD 330-30 323	64531	252
578923310	FD 330-30 340	64532	252
578923310	FD 330-30 371	64535	253
578923310	FD 330-30 513	64541	255
578923310	FD 330-30 370	64534	253
578923310	FD 330-30 369	64533	252
578923310	FD 330-30 502	64539	254
578923310	FD 330-30 372	64536	253
578923315	FD 331-26 514	64597	256
578923315	FD 330-30 369	64533	252
578923315	FD 331-26 480	64284	256
578923315	FD 331-26 541	64599	256
578923350	FD 530-22 311	64543	257
578923353	FD 530-22 321	64545	257
578923353	FD 530-22 374	64548	258
578923353	FD 530-22 316	64544	257
578923353	FD 530-22 345	64547	258
578923353	FD 530-30 449	64589	259
578923353	FD 530-22 342	64546	258
578923356	FD 530-35 544	64606	261
578923356	FD 530-35 530	64604	261
578923356	FD 530-35 1165	77199	263
578923356	FD 530-30 532	64593	260
578923356	FD 530-35 543	64605	261
578923356	FD 530-30 451	64590	259
578933100	FT 330-29 503	64568	269
578933100	FT 330-29 546	64572	270
578933100	FT 330-29 520	64570	269
578933100	FT 330-29 525	64571	269
578933100	FT 330-29 434	64285	267
578933100	FT 330-29 498	64567	268
578933100	FT 330-29 413	64560	266
578933100	FT 330-29 703	64648	271
578933100	FT 330-29 466	64565	268

**Goodyear bellows CT**

578933100	FT 330-29 547	64573	270
578933100	FT 330-29 723	64710	272
578933100	FT 330-29 431	64562	266
578933103	FT 430-35 1188	78687	275
578933103	FT 430-35 1178	77340	274
578933103	FT 330-29 790	69747	273
578 93 3 104	FT 430-35 1298	601025	275
578933105	FT 330-29 554	66522	271
578933105	FT 330-29 875	69641	274
578933335	FT 530-35 456	64582	280
578933350	FT 530-32 329	64504	276
578933350	FT 530-35 455	64581	280
578933350	FT 530-32 325	64503	276
578933350	FT 530-32 336	64506	277
578933350	FT 530-35 457	64583	280
578933350	FT 530-32 333	64505	276
579101083	SC29-Y036	68162	301
579101115	SC31-W206	67452	306
579101116	SC31-Y215	68161	306
579923515	FD 110-15 766	66094	228
579923526	FD 110-17A 775	67667	228
579923530	FD 120-20 509	64601	229
580-23-4-604	SC29-B093	75313	288
758-93-3-100	FT 330-29 1007	75142	274









## Fitment Guide Manufacturer > ContiTech

Lista de Aplicaciones  
Fabricante > ContiTech



MANUFACTURER	CT	No.	2	3
<b>3-T's</b>				
W02-T03-7049	SC29-0049	69925	291	
W02-T03-7100	SC29-0100	67637	293	
W02-T03-7103	SC29-W103	67860	301	
<b>Air Flex</b>				
W02-A05-7037	SC29-W037	70017	298	
W02-A05-7067	SC29-W067	69931	299	
<b>American Carrier</b>				
8003-003	9 9-12 P 705	64627	52	
8003-005	FD 530-22 342	64546	258	
8003-006	FD 120-20 509	64601	229	
8003-007	FS 530-14 447	64525	218	
8003-011	6 6.5-13 S 041	68124	40	
8003-013	FS 530-14 515	64526	219	
8003-017	6 6.5-11 S 031	68112	34	
8003-023	9 9-12 P 1476	79614	55	
8003-025	9 9M-13 P 1290	77427	59	
9003-001	6 6.5-11 S 030	68111	33	
<b>Binkley</b>				
XB-SPN-053-37	9 10-12 P 484	64456	82	
XB-SPN-053-37	FD 331-26 480	64284	256	
<b>Bluebird</b>				
1263581	6 6.5D-11 S 525	68119	38	
12TA-1-2	9 10-10 P 311	64260	70	
300-961250	9 10-10 P 311	64260	70	
300-961425	6 6.5D-11 S 525	68119	38	
90557038	9 10-12 P 319	64445	78	
990671	9 9M-13 P 1181	75179	57	
<b>BPW</b>				
02.200.24.40.0	5S 8-15.5 (644N)	66141	32	
<b>Brake &amp; Wheel</b>				
M3500	FD 200-19 310	64509	231	
M3502	FD 530-22 311	64543	257	
M3503	FD 530-22 321	64545	257	
M3505	FD 530-22 374	64548	258	
M3506	FD 330-22 313	64270	245	
M3507	FD 330-22 318	64488	246	
M3508	FD 330-22 331	64268	246	
M3509	FD 330-22 327	64283	246	
M3510	11 10.5C-16 A 320	64254	191	
M3512	9 10-14 A 312	75626	92	
M3512	9 10-14 P 312	64274	93	
M3513	9 10-16 A 310	70115	108	

MANUFACTURER	CT	No.	2	3
M3513	9 10-16 P 310	64269	108	
M3514	9 10-16 P 333	64294	109	
M3516	9 10-12 P 319	64445	78	
M3517	11 10.5-17 A 317	64272	197	
M3518	11 10.5-21 A 313	64273	206	
M3519	9 10-19 P 321	64280	150	
M3520	11 10.5-21 A 318	64352	206	
M3521	11 10.5-17 A 316	64342	196	
M3522	9 10-16 P 441	64308	115	
M3523	9 10-19 A 358	64327	152	
M3523	9 10-19 P 358	64615	152	
M3523	9 10-19 P 383	64281	153	
M3524	9 10-19 P 435	64288	153	
M3525	9 9-12 P 314	64255	48	
M3526	9 10-16 P 410	64276	114	
M3527	FS 330-11 467	64594	216	
M3528	FD 200-19 505	64517	234	
M3531	FD 331-26 480	64284	256	
M3533	FT 530-32 336	64506	277	
M3535	11 10.5C-16 A 378	64357	191	
M3536	9 9-12 A 334	64360	48	
M3538	9 10-19 P 326	64323	150	
M3539	9 10-16 P 352	64297	110	
M3540	9 10-16 P 408	64259	113	
M3542	9 10-13.5 S 433	64287	89	
M3544	9 9K-15 P 417	64386	65	
M3545	9 10-21 A 361	64715	162	
M3545	9 10-21 P 361	64291	163	
M3546	9 10-19 A 358	64327	152	
M3546	9 10-19 P 358	64615	152	
M3546	9 10-19 P 383	64281	153	
M3547	9 9-12 P 705	64627	52	
M3548	9 10-17.5 P 429	64278	129	
M3550	9 10S-16 P 382	67473	121	
<b>Büssing</b>				
536 905 265	5S 8-15.5 (644N)	66141	32	
546 905 134	6S 9.5-15.5 (661 N)	68461	32	
546 905 134	6S 9.5-15.5 (661 N)	68461	32	
831 120 144	6S 9.5-15.5 (661 N)	68461	32	
831 120 144	6S 9.5-15.5 (661 N)	68461	32	
831 120 144	6S 9.5-15.5 (661 N)	68461	32	
831 120 144	6S 9.5-15.5 (661 N)	68461	32	
831 120 144	6S 9.5-15.5 (661 N)	68461	32	

MANUFACTURER	CT	No.	2	3
<b>Chevrolet</b>				
15630691	9 10-14 P 381	64470	96	
15963147	9 10-12 P 487 (BK)	69645	83	
15963148	9 10-12 P 487 (BK)	69645	83	
1622372C1	9 10-18.5 P 406 (BK)	68615	144	
2076095	FD 330-22 337	64490	247	
693230	FD 330-22 313	64270	245	
711954	FD 330-22 337	64490	247	
<b>Connect Air Springs</b>				
198729	10 10A-12 P 1330	77963	168	
<b>Cush</b>				
C-0060	9 10-19.5 A 801	65387	161	
C-0073	FD 331-26 480	64284	256	
C-0079	9 10-17.5 A 802	64762	137	
C-0080	FD 200-25 429	64552	242	
C-0083	FD 530-35 545	64607	262	
C-0294	11 10.5C-16 A 320	64254	191	
<b>DANA/SPICER</b>				
SR1JA100	10 10.5AV-16 P 1219	78239	185	
SR1VA101-1	10 10.5AV-16 P 1219	78239	185	
SR1VA105	10 10.5AV-16 P 1219	78239	185	
<b>Dart</b>				
21-4048	11 10.5-17 A 368	65358	198	
<b>Dayton</b>				
352-8050	11 10.5C-16 A 320	64254	191	
352-9011	9 10-14 P 346	64467	94	
352-9039	9 10-10 P 311	64260	70	
352-9053	9 10-12 A 327	64446	79	
352-9069	9 10-14 A 312	75626	92	
352-9069	9 10-14 P 312	64274	93	
352-9082	10 10.5AV-16 P 1219	78239	185	
352-9082	9 10-16 A 310	70115	108	
352-9082	9 10-16 P 310	64269	108	
352-9083	9 10-16 P 333	64294	109	
352-9096	9 10-16 P 325	64292	108	
352-9101	9 10-19 P 315	64279	150	
352-9105	9 10-12 P 319	64445	78	
352-9121	11 10.5-17 A 317	64272	197	
352-9122	11 10.5-21 A 313	64273	206	
352-9130	9 10-19 P 321	64280	150	
352-9148	11 10.5-17 A 364	64343	197	
352-9149	11 10.5-17 A 365	64344	197	
352-9158	11 10.5-21 A 318	64352	206	

MANUFACTURER	CT	No.	2	3
352-9177	11 10.5-17 A 316	64342	196	
352-9192	9 10-19 P 326	64323	150	
352-9194	9 10-16 P 352	64297	110	
352-9200	11 10.5-15 A 415	64253	188	
352-9203	9 10-19 P 355	64324	151	
352-9213	9 10-16 P 441	64308	115	
352-9215	11 10.5-15 A 414	64424	188	
352-9227	9 10-16 P 353	64298	110	
352-9238	9 10-19 P 356	64325	151	
352-9321	9 10-21 A 361	64715	162	
352-9321	9 10-21 P 361	64291	163	
352-9349	9 10-19 P 438	64335	154	
352-9415	9 9-14 P 322	64378	60	
352-9422	9 9-12 P 314	64255	48	
354-6801	FD 530-30 451	64590	259	
354-6803	FD 530-30 449	64589	259	
354-6902	FD 200-19 310	64509	231	
354-6905	FD 200-19 315	64510	231	
354-6910	FD 200-19 320	64267	232	
354-6947	FD 200-25 428	64551	242	
354-7112	FS 530-14 339	64521	217	
354-7123	FD 530-22 345	64547	258	
354-7135	FD 530-22 311	64543	257	
354-7136	FD 530-22 321	64545	257	
354-7140	FD 530-22 316	64544	257	
354-7145	FD 530-22 374	64548	258	
354-7146	FD 530-22 342	64546	258	
354-7181	FD 330-22 472	64500	250	
354-7183	FD 330-22 471	64499	250	
354-7400	FD 330-22 313	64270	245	
354-7403	FD 330-22 318	64488	246	
354-7404	FD 330-22 346	64492	248	
354-7406	FD 330-22 365	64495	249	
354-7409	FD 330-22 367	64497	249	
354-7410	FD 330-22 331	64268	246	
354-7424	FD 330-22 327	64283	246	
354-7429	FD 330-22 343	64491	247	
354-7437	FD 330-22 334	64489	247	
354-7443	FD 330-30 323	64531	252	
354-7446	FD 330-30 370	64534	253	
354-7447	FD 330-30 340	64532	252	
354-7798	FT 530-32 329	64504	276	
354-7800	FT 530-32 333	64505	276	

MANUFACTURER	CT	No.	2	3
354-7808	FT 530-32 336	64506	277	
354-7818	FT 530-32 325	64503	276	
354-7839	FT 530-35 437	64577	278	
354-7846	FT 530-35 456	64582	280	
354-7847	FT 530-35 457	64583	280	
354-8008	FT 330-29 431	64562	266	
354-8008	FT 330-29 469	64566	268	
<b>DINA</b>				
A-8127-19	FD 200-19 320	64267	232	
AZ-8127-19	FD 200-19 319	64271	231	
<b>DYNA CRAFT</b>				
D5000-2253	SC29-O155	75314	294	
<b>Eldorado Bus</b>				
7089	9 9-12 P 563	64286	52	
7113D000	6 6.5-13 S 042	68125	40	
<b>Eveley</b>				
RA 1954-11	9 10-16 P 500	64317	116	
RA 1954-4	11 10.5-21 A 313	64273	206	
RA 1954-5	9 10-16 A 310	70115	108	
RA 1954-5	9 10-16 P 310	64269	108	
RA 1990-1	FD 530-22 311	64543	257	
<b>EvoBus</b>				
322 327 03 01	5S 8-15.5 (644N)	66141	32	
A 000 320 03 21	5S 8-15.5 (644N)	66141	32	
A 000 327 02 01	5S 8-15.5 (644N)	66141	32	
A 307 328 00 01	5S 8-15.5 (644N)	66141	32	
A 307 328 00 01	5S 8-15.5 (644N)	66141	32	
A 327 328 00 01	5S 8-15.5 (644N)	66141	32	
A 410 327 00 01	6S 9.5-15.5 (661 N)	68461	32	
A 613 327 00 01	5S 8-15.5 (644N)	66141	32	
<b>EZ Ride</b>				
8030120	FD 200-19 315	64510	231	
8030150	FD 330-30 340	64532	252	
8030155	FT 330-29 431	64562	266	
8030160	FD 530-30 451	64590	259	
8030170	FT 530-32 336	64506	277	
8030180	FT 530-32 325	64503	276	
8030180	FT 530-35 437	64577	278	
8030190	FD 330-22 363	64493	248	
8030192	9 10-12 A 327	64446	79	
<b>Fab Tek</b>				
04-0080	FD 330-22 313	64270	245	
101357	9 10-14 P 349	64469	95	

MANUFACTURER	CT	No.	2	3
101827	9 10-10 P 311	64260	70	
101929	9 10-16 A 310	70115	108	
101929	9 10-16 P 310	64269	108	
10828	9 10-12 A 327	64446	79	
<b>Flexible</b>				
6-304-157	9 9K-15 P 1147	74792	67	
6-336-11	6 6.5-13 S 056	68136	42	
6-336-13	FD 330-22 500	64501	251	
6-336-174	9 9K-15 P 1147	74792	67	
6-336-196	6 6.5D-11 S 525	68119	38	
6-336-2	6 6.5-11 S 030	68111	33	
6-336-200	9 9-14 P 1146	74791	63	
6-336-202	9 10-10 P 311	64260	70	
6-336-205	9 10-12 P 319	64445	78	
6-336-4	6 6.5-11 S 048	68132	34	
6-336-5	FD 330-22 500	64501	251	
6-379-1	6 6.5-11 S 031	68112	34	
6-379-2	9 10-10 P 339	64433	72	
6-379-6	6 6.5-11 S 051	68133	35	
6-841-92	9 9K-15 P 1147	74792	67	
6-9999-00178	6S 9.5-15.5 (661 N)	68461	32	
6336212	9 9M-13 P 1181	75179	57	
97-240-153	9 9K-15 P 1147	74792	67	
97-9999-01867	SC29-O001	67770	290	
<b>Ford</b>				
E9HZ5580A	9 10-16 P 410	64276	114	
F2HZ5580A	9 10-18.5 P 406 (BK)	68615	144	
F3HS5580AA	9 10-14 P 465 (BK)	69644	97	
F6HT5C06CAB	SC29-O201	67766	295	
F6HT5C063BA	SC29-B200	67767	289	
FOHZ5580A	9 10-18.5 P 406 (BK)	68615	144	
<b>Freightliner</b>				
16-10796-000	FD 330-22 313	64270	245	
16-11378-000	FD 330-22 331	64268	246	
16-13810-000	9 10S-16 S 382	77614	121	
16-13810-000	9 10S-16 A 382	64266	120	
16-13810-000	9 10S-16 P 382	67473	121	
16-13810-001	9 10S-16 P 382	67473	121	
16-13810-002	9 10S-16 P 382	67473	121	
16-13840-000	9 10S-16 S 382	77614	121	
16-13840-000	9 10S-16 A 382	64266	120	
16-13840-000	9 10S-16 P 382	67473	121	
16-14004-000	9 10S-16 S 382	77614	121	

MANUFACTURER	CT	No.	2 3
16-14004-000	9 10S-16 A 382	64266	120
16-14004-000	9 10S-16 P 382	67473	121
16-14004-001	9 10S-16 S 382	77614	121
16-14004-001	9 10S-16 A 382	64266	120
16-14004-001	9 10S-16 P 382	67473	121
16-14263-000	9 10-14 P 575	65361	101
16-14263-001	9 10-14 P 575	65361	101
16-14318-000	FD 200-19 499	64515	233
16-14377-000	9 10S-16 P 382	67473	121
16-15443-000	9 10-14 P 575	65361	101
16-15443-001	9 10-14 P 575	65361	101
16-15444-000	9 10-14 P 575	65361	101
16-15595-000	9 10S-16 S 382	77614	121
16-15595-000	9 10S-16 A 382	64266	120
16-15595-000	9 10S-16 P 382	67473	121
16-15595-001	9 10S-16 P 382	67473	121
16-15595-002	9 10S-16 P 382	67473	121
16-15762-000	9 10-13.5 P 232	69800	88
16-16019-000	9 10-12 P 1291	77433	87
16-16773-000	9 10S-16 S 382	77614	121
16-16773-000	9 10S-16 A 382	64266	120
16-16773-000	9 10S-16 P 382	67473	121
16-16825-000	9 10S-16 P 382	67473	121
16-19465-000	9 10S-16 S 382	77614	121
16-19465-000	9 10S-16 A 382	64266	120
16-19466-000	9 10S-16 S 382	77614	121
16-19466-000	9 10S-16 A 382	64266	120
16-19467-000	9 10S-16 P 382	67473	121
16-19468-000	9 10S-16 P 382	67473	121
16-19769-000	9 10S-16 P 999	68208	122
18-29919-000	SC31-W206	67452	306
18-40977-000	SC31-Y215	68161	306
18-42609-000	SC29-B200	67767	289
18-45068-000	SC29-O201	67766	295
18-52651-000	SC31-Y215	68161	306
18-66715-000	SC31-Y215	68161	306
66003-3405	SC29-Y082	67853	302
66003-3406	SC31-Y205	67638	306
681-320-0017	9 10S-16 S 382	77614	121
681-320-0017	9 10S-16 A 382	64266	120
681-320-0017	9 10S-16 P 382	67473	121
A16-13668-002	9 10S-16 P 382	67473	121
A16-14004-000	9 10S-16 S 382	77614	121

MANUFACTURER	CT	No.	2 3
A16-14004-000	9 10S-16 A 382	64266	120
A16-14004-000	9 10S-16 P 382	67473	121
A16-17574-000	9 10S-16 A 999	68207	121
A16-17574-001	9 10S-16 A 999	68207	121
A16-17574-002	9 10S-16 A 999	68207	121
A16-18333-000	9 10S-13 P 264	70023	88
A16-18333-001	9 10S-13 P 264	70023	88
A16-18335-000	9 10S-16 P 999	68208	122
A16-18335-001	9 10S-16 P 999	68208	122
A16-19677-000	9 10S-16 A 999	68207	121
A16-19677-001	9 10S-16 A 999	68207	121
A16-20121-000	9 10S-16 P 1631	601986	123
A16-20121-001	9 10S-16 P 1631	601986	123
A16-21556-000	9 10S-16 A 1634	601989	123
A16-21556-001	9 10S-16 A 1634	601989	123
A16-21557-000	9 10S-16 P 1600	601538	122
A16-21557-001	9 10S-16 P 1600	601538	122
GYR 1S5-040	SC29-W087	67636	300
GYR1S5045	SC29-YG02	70825	304
<b>Fruehauf</b>			
MFR-022354	9 10-10 P 331	64431	71
MFR-022355	9 10-12 P 329	64447	79
UAB-5620	FD 330-22 472	64500	250
UCA-0112	FD 330-22 471	64499	250
UCA-0112-B	FD 330-22 471	64499	250
UCB-44531	9 10-10 P 331	64431	71
UCB-9668-1	9 10-12 P 329	64447	79
UCC-3054-1	FD 330-22 472	64500	250
UCD-9393-2	9 10-19 A 358	64327	152
UCD-9393-2	9 10-19 P 358	64615	152
UCD-9393-2	9 10-19 P 383	64281	153
UCE-1304-1	9 10-16 P 325	64292	108
UCE-1304-2	9 10-12 A 327	64446	79
UCE-9393-1	9 10-16 P 333	64294	109
UCE-9393-1	9 10-19 A 358	64327	152
UCE-9393-1	9 10-19 P 321	64280	150
UCE-9393-1	9 10-19 P 358	64615	152
UCE-9393-1	9 10-19 P 383	64281	153
UCE-9393-2	9 10-19 A 358	64327	152
UCE-9393-2	9 10-19 P 358	64615	152
UCE-9393-2	9 10-19 P 383	64281	153
UCE-9393-3	9 10-19 A 358	64327	152
UCE-9393-3	9 10-19 P 321	64280	150

MANUFACTURER	CT	No.	2	3
UCE-9393-3	9 10-19 P 358	64615	152	
UCE-9393-3	9 10-19 P 383	64281	153	
UCE-9393-4	9 10-19 A 358	64327	152	
UCE-9393-4	9 10-19 P 321	64280	150	
UCE-9393-4	9 10-19 P 358	64615	152	
UCE-9393-4	9 10-19 P 383	64281	153	
<b>FUSO</b>				
MK459314	9 10-14 P 875	67449	103	
MK459315	9 10-16 P 876	67450	118	
<b>Gillig</b>				
0837209-000N	6 6.5B-11 S 054	68135	37	
5309611001	9 10-14 A 330	64464	93	
5313187	99-14 P 1146	74791	63	
5313188	11 10.5-17 A 365	64344	197	
5314006	99-14 P 1146	74791	63	
5317602001	9 10-16 A 310	70115	108	
5317602001	9 10-16 P 310	64269	108	
5320415-0001	11 10.5C-16 A 380	64358	192	
538212	99-14 P 1146	74791	63	
8717289	9 10-12 P 395	64451	80	
<b>GMC</b>				
10530087	99K-15 P 1147	74792	67	
15963160	9 10-18.5 P 406 (BK)	68615	144	
2383257	99K-15 P 1147	74792	67	
661756	99K-15 P 1147	74792	67	
661759A	99K-15 P 1147	74792	67	
661759C	99K-15 P 1147	74792	67	
662743	6 6.5-13 S 039	68121	39	
662743	6 6.5-13 S 056	68136	42	
665621	99K-15 P 1147	74792	67	
677302	99K-15 P 1147	74792	67	
684192	99K-15 P 1147	74792	67	
684193	99K-15 P 1147	74792	67	
6841953	99K-15 P 1147	74792	67	
68419C	99K-15 P 1147	74792	67	
684242C	99K-15 P 1147	74792	67	
693230	FD 330-22 313	64270	245	
698935	99K-15 P 1147	74792	67	
711954	FD 330-22 334	64489	247	
716111	6 6.5-13 S 039	68121	39	
8865456	6 6.5-13 S 039	68121	39	
8870485	99K-15 P 1147	74792	67	
8875032	99K-15 P 1147	74792	67	

MANUFACTURER	CT	No.	2	3
G1019449	9 9K-15 P 1147	74792	67	
G1019450	9 9K-15 P 1147	74792	67	
<b>Granning</b>				
1014	FT 530-32 325	64503	276	
1015	FD 530-22 316	64544	257	
1218	FD 330-30 323	64531	252	
1359	9 10-16 P 333	64294	109	
1371	FD 200-19 320	64267	232	
1476	FT 530-35 437	64577	278	
1528	9 10-16 P 333	64294	109	
15765	6 6.5-13 S 039	68121	39	
1589	FD 330-30 323	64531	252	
1613	FT 530-32 329	64504	276	
1613	FT 530-35 436	64576	278	
1626	FD 530-22 321	64545	257	
1971	6 6.5-13 S 039	68121	39	
2112	6 6.5-13 S 446	68123	42	
2725	FD 330-22 318	64488	246	
2726	FD 200-19 320	64267	232	
2726	FD 330-22 313	64270	245	
2727	9 10-16 A 310	70115	108	
2727	9 10-16 P 310	64269	108	
2727	9 10-17.5 P 418	64334	128	
4514	FT 530-32 333	64505	276	
4848	FD 200-19 310	64509	231	
4848	FD 200-19 499	64515	233	
5065	9 10-12 P 319	64445	78	
5122	6 6.5B-11 S 027	68108	37	
5235	6 6.5-13 S 559	68127	43	
5307	6 6.5-13 S 559	68127	43	
5691	6 6.5-11 S 028	68109	33	
6104	6 6.5-11 S 028	68109	33	
6250	6 6.5-13 S 047	68131	42	
6352	FD 200-25 426	64549	241	
6389	FD 200-19 315	64510	231	
6390	FD 200-25 454	64554	243	
6391	FD 330-30 370	64534	253	
6392	FT 330-29 431	64562	266	
6393	FT 330-29 434	64285	267	
6394	11 10.5-21 A 313	64273	206	
6396	9 10-19 P 390	64331	153	
6418	9 10-16 A 310	70115	108	
6418	9 10-16 P 310	64269	108	

MANUFACTURER	CT	No.	2 3
6419	FS 530-14 339	64521	217
6420	FD 530-22 311	64543	257
6421	FD 330-22 327	64283	246
6422	FD 330-22 334	64489	247
6425	11 10.5-21 A 318	64352	206
6426	11 10.5-17 A 316	64342	196
6427	9 10D-21 A 324	64375	166
6941	9 10-19 P 315	64279	150
700029-01	10 10-16.5 S 262	70010	180
700195-01	10 10-14 S 736	64625	169
7025	FD 200-25 507	64556	243
7026	FT 530-35 522	64585	281
702932-01	FD 200-19 499	64515	233
702932-01	FT 330-29 520	64570	269
704691-01	9 10-13.5 S 734	64667	89
712151-01	10 10K-13 S 1025	73071	169
7504	6 6.5-11 S 032	68113	34
7593	11 10.5-13 A 1132	74618	187
7631	FD 200-19 448	64512	232
7639	FD 200-25 454	64554	243
7640	9 10-21 A 361	64715	162
7640	9 10-21 P 361	64291	163
7765	6 6.5-13 S 045	68129	41
7831	6 6.5-13 S 046	68130	41
7901	10 10-16.5 S 262	70010	180
8221	FT 330-29 520	64570	269
B59	9 10-16 P 333	64294	109
<b>Hanomag</b>			
536 905 265	6S 9.5-15.5 (661 N)	68461	32
536 905 265	6S 9.5-15.5 (661 N)	68461	32
536 905 265	6S 9.5-15.5 (661 N)	68461	32
536 905 265	6S 9.5-15.5 (661 N)	68461	32
536 905 265	6S 9.5-15.5 (661 N)	68461	32
536 905 265	6S 9.5-15.5 (661 N)	68461	32
536 905 265	6S 9.5-15.5 (661 N)	68461	32
536 905 266	6S 9.5-15.5 (661 N)	68461	32
546 905 134	5S 8-15.5 (644N)	66141	32
<b>Hendrickson</b>			
1015	FT 330-29 790	69747	273
10214	FD 200-22 A 908	600929	240
10343	FT 330-29 821	70123	273
1285	FT 530-35 523	64586	281
1346	FT 530-32 535	64507	277

MANUFACTURER	CT	No.	2 3
1347	FD 110-17A 789	67553	228
13675	9 10JS-13 S 1104	78242	88
13676	9 10BS-14 S 1096	78243	107
13677	10 10BS-14 S 1124	78244	170
1475	FD 330-30 513	64541	255
1503	FD 330-30 512	64540	254
1560	FT 330-29 548	64574	270
1795	FT 530-35 534	64587	282
1796	FD 331-26 514	64597	256
2878	FD 200-22 524	64602	239
3316	FT 330-29 525	64571	269
3317	FD 200-19 713	67705	236
3318	FD 200-19A 730	70120	238
3319	9 10-21 A 505	64716	163
3319	9 10-21 P 505	64384	164
36514-10	11 10.5-21 A 313	64273	206
36514-11	11 10.5-21 A 318	64352	206
36514-12	11 10.5C-16 A 378	64357	191
36514-13	11 10.5C-16 A 320	64254	191
36514-2	11 10.5-21 A 313	64273	206
36514-3	9 10-12 P 343	64450	80
36514-4	11 10.5-21 A 318	64352	206
36514-5	FD 330-30 371	64535	253
36514-7	9 10-16 A 310	70115	108
36514-7	9 10-16 P 310	64269	108
36514-8	11 10.5-21 A 313	64273	206
45843-1	FD 200-19 315	64510	231
45843-3	FD 200-19 320	64267	232
48195-1	9 10-16 P 353	64298	110
48195-2	9 10-16 P 409	64275	114
4828	FT 530-35 726	65828	282
49048	9 10-16 P 410	64276	114
49048-2	9 10-16 P 410	64276	114
49160	9 10-16 P 371	64300	111
49207	9 10-16 P 410	64276	114
49674-1	9 10-16 P 410	64276	114
49674-2	9 10-16 P 410	64276	114
50405-2	9 10-18.5 P 406 (BK)	68615	144
5079	FD 110-17A 775	67667	228
5079	FD 110-17A 804	68160	229
50898-2	9 10-18.5 P 935 (BK)	66978	146
50899-1	9 10-18.5 P 451 (BK)	68616	144
50899-2	9 10-18.5 P 451 (BK)	68616	144

MANUFACTURER	CT	No.	2 3
5360	FD 200-22A 1062	78246	240
56808-2	9 10-12 P 487 (BK)	69645	83
56917-1	9 10-14 P 465 (BK)	69644	97
56917-2	9 10-14 P 465 (BK)	69644	97
57122-1	9 10-18.5 P 519 (BK)	64265	144
57122-2	9 10-18.5 P 519 (BK)	64265	144
57140LH	9 10-12 P 487 (BK)	69645	83
57150RH	9 10-12 P 487 (BK)	69645	83
58520-2	9 10-18.5 P 095 (BK)	68612	142
58520-2D	9 10-18.5 P 095 (BK)	68612	142
58786-2	9 10-18.5 P 550 (BK)	69659	145
58983-2	99-14 P 1319	77797	64
58995-2	9 10-16 P 549 (BK)	69658	117
59010-2	9 10-18.5 P 1322	77861	147
59484-2	9 10-10 P 204	69625	70
59823-2C	6 6.5B-11 P 235	69914	36
59861-002	9 10-18.5 P 1139 (BK)	74762	146
60271-2	9 10-18.5 P 939 (BK)	67573	146
60716-2	99K-12 P 093	68608	56
60750-2	6 6.5B-11 P 236	69915	36
60750-2E	6 6.5B-11 P 236	69915	36
60925-2	9 10-14 P 906 (BK)	68154	104
60929-2	9 10-14 P 905 (BK)	68153	104
64075-2	6 6.5B-11 P 236	69915	36
64489-002	9 10-18.5 P 095 (BK)	68612	142
64489-2	9 10-18.5 P 095 (BK)	68612	142
64651-2	9 10-18.5 P 096 (BK)	68613	143
64651-2	9 10-18.5 P 935 (BK)	66978	146
65032-2	9 10-18.5 P 097	68614	143
65183-002	9 10-18.5 P 111 (BK)	69801	143
66349-2	6 6.5B-11 P 236	69915	36
67043-002	9 10BS-17 P 1192 (BK)	75266	124
67304-2	6 6.5B-11 P 237	69916	36
67391-2	9 10BS-17 P 1193	75267	124
67392-2	9 10BS-17 P 1193 (BK)	77593	125
69782-002	6 6.5B-11 P 235	69914	36
698132	10 10-15 S 962	67600	174
77619-000	10 10S-14 S 1095 (BK)	78248	172
7795	FT 530-32 1088	78245	278
78546-000	9 10SW-14 S 1208 (BK)	78249	107
78824-000	6 6.5-11 S 1259	78247	35
9189	FD 200-25 797	67905	245
98734-003	9 10-10 S 221	69767	70

MANUFACTURER	CT	No.	2 3
98734016	9 9K-15 P 1147	74792	67
B-12335	FD 330-30 371	64535	253
B-12514-001	FD 330-22 318	64488	246
B-12514-003	9 10-12 P 343	64450	80
B-12514-007	9 10-16 A 310	70115	108
B-12514-007	9 10-16 P 310	64269	108
B-12514-012	11 10.5C-16 A 378	64357	191
B-12514-013	11 10.5C-16 A 320	64254	191
B-14249	9 10-21 A 361	64715	162
B-14249	9 10-21 A 505	64716	163
B-14249	9 10-21 P 361	64291	163
B-14249	9 10-21 P 505	64384	164
B-14486	FD 200-19 713	67705	236
B-14487	FT 330-29 525	64571	269
B-14487	FT 330-29 714	67904	271
B-34050-1	SC17-WC10	77548	286
B-34050-2	SC17-WC08	77546	286
B-34051-1	SC17-WC11	77549	287
B-34051-2	SC17-WC09	77547	286
B-3411	9 10-16 A 354	64299	110
B-3842	9 10-19 P 315	64279	150
B-4375	9 10-21 A 505	64716	163
B-4375	9 10-21 P 505	64384	164
B-4771	11 10.5C-16 A 320	64254	191
B-4773	9 10-16 P 376	64302	111
B-7193	99-14 P 322	64378	60
C-10443	9 10-19 P 973	67703	159
C-20217	9 10-16 P 710	64634	117
C-20413	9 10-19 P 435	64288	153
C-20901	11 10.5A-16 P 523	64421	190
C-21624	10 10-15 P 711	64635	173
C-22173	11 10.5-21 A 313	64273	206
C-23748	11 10.5B-18 P 743	65368	201
C-24445	11 10.5-22 S 1199	75465	212
C-24446	11 10.5-24 S 1200	75464	213
C-24488	SC26-WC12	77550	287
C-24774	11 10.5-22 S 1221	78237	212
C-25319	11 10.5D-21 S 1063	75269	209
C-25871	10 10.5V-22 S 1179	75268	186
C-25872	10 10.5V-24 S 1060	73913	186
C-25873	11 10.5F-17 P 745	65593	200
C-33001	10 10K-14 S 1024	78241	171
C-33247	10 10K-14 S 1022	78231	171



MANUFACTURER	CT	No.	2 3
HA400	9 10-16 P 410	64276	114
HA460	9 10-16 P 410	64276	114
NA1817	9 10-19 P 326	64323	150
NS501304	9 10-21 A 361	64715	162
NS501304	9 10-21 P 361	64291	163
NS502049	9 10-18.5 P 406 (BK)	68615	144
S-1013	FD 330-22 313	64270	245
S-10170	FD 330-22 331	64268	246
S-10214	FD 200-19 836	70121	237
S-10352	9 10-19 A 358	64327	152
S-10352	9 10-19 P 357	64326	151
S-10352	9 10-19 P 358	64615	152
S-10352	9 10-19 P 383	64281	153
S-10443	9 10-19 P 315	64279	150
S-1080	FD 530-22 321	64545	257
S-11566	9 10-14 P 345	64258	94
S-1159	FD 330-22 318	64488	246
S-11637	FT 330-29 431	64562	266
S-11650	9 10-10 P 311	64260	70
S-11651	9 10-16 A 310	70115	108
S-11651	9 10-16 P 310	64269	108
S-12353	9 10-16 P 372	64301	111
S-12405	FT 330-29 413	64560	266
S-12437	11 10.5-21 A 313	64273	206
S-1245/36514-3	9 10-12 P 319	64445	78
S-12514-004	11 10.5-21 A 318	64352	206
S-12514-005	FD 330-30 371	64535	253
S-12514-008	11 10.5-21 A 313	64273	206
S-12514-010	11 10.5-21 A 313	64273	206
S-12514-011	11 10.5-21 A 318	64352	206
S-12514-014	FD 530-22 311	64543	257
S-13031	9 10-14 A 312	75626	92
S-13031	9 10-14 P 312	64274	93
S-13032	99-12 P 314	64255	48
S-13033	9 10-16 P 441	64308	115
S-13034	FD 530-22 311	64543	257
S-13035	FD 330-30 323	64531	252
S-13036	FD 330-22 331	64268	246
S-13037	FD 330-22 334	64489	247
S-13038	FD 530-22 374	64548	258
S-13039	FT 530-32 329	64504	276
S-13039	FT 530-35 436	64576	278
S-13040	99-14 P 322	64378	60

MANUFACTURER	CT	No.	2 3
S-13040	9 9M-13 P 1181	75179	57
S-13041	FT 530-32 325	64503	276
S-13042	9 10-16 P 333	64294	109
S-13043	FD 330-22 327	64283	246
S-13044	FS 530-14 339	64521	217
S-13045	11 10.5-17 A 365	64344	197
S-13046	FD 530-22 342	64546	258
S-13047	FT 530-35 439	64579	279
S-13048	FD 530-22 345	64547	258
S-13049	9 10-16 P 325	64292	108
S-13050	FD 330-22 472	64500	250
S-13052	FD 330-22 343	64491	247
S-13053	11 10.5-17 A 364	64343	197
S-13122	11 10.5-24 S 712	64637	213
S-13155	6 6.5-13 S 042	68125	40
S-13157	FT 530-32 336	64506	277
S-13158	9 10-12 A 327	64446	79
S-13159	9 10-16 A 310	70115	108
S-13159	9 10-16 P 310	64269	108
S-13160	11 10.5-17 A 317	64272	197
S-13161	9 10-19 P 321	64280	150
S-13163	9 10-16 P 352	64297	110
S-1345	FD 330-22 346	64492	248
S-14147	9 9M-13 P 1182	75180	57
S-14318	FD 200-19 499	64515	233
S-14395	FD 120-20 509	64601	229
S-1561	9 10-16 P 333	64294	109
S-20010	9 10-13.5 S 433	64287	89
S-20124	9 10-19 P 435	64288	153
S-20127	10 10-21 P 434	64394	182
S-20217	9 10-17.5 P 436	64401	130
S-20223	9 10-12 A 427	64395	81
S-20228	9 10-12 P 544	64463	84
S-20413	9 10-19 P 435	64288	153
S-20414	10 10-21 P 015	67951	181
S-2063	11 10.5-21 A 318	64352	206
S-2064	9 10-10 P 311	64260	70
S-2065	11 10.5-17 A 316	64342	196
S-2066	9 10-16 A 310	70115	108
S-2066	9 10-16 P 310	64269	108
S-20716	9 10-16 P 710	64634	117
S-20900	10 10.5-15 P 460	64645	185
S-20900	10 10-15 P 453	64624	172

MANUFACTURER	CT	No.	2 3
S-21208	9 10-13.5 S 881	66447	90
S-21323	FD 200-25 511	64557	244
S-21623	10 10-15 P 522	64397	173
S-21800	10 10.5-15 P 460	64645	185
S-21966	10 10-16 P 526	64638	177
S-22045	10 10-15 P 522	64397	173
S-22046	10 10-15 P 711	64635	173
S-22173	11 10.5-22 A 931	68159	211
S-22948	10 10-16 P 533	64636	177
S-2307	9 10-14 P 346	64467	94
S-23114	FD 200-23A 709	64683	241
S-23611	9 10BP-20 P 738	64694	162
S-23612	9 10BP-22 P 739	64695	167
S-23613	9 9B-20 P 740	64696	69
S-23614	9 9B-22 P 741	64697	69
S-23720	9 9-16 P 568	64692	68
S-23721	9 10BP-16 P 569	64693	120
S-2394	6 6.5B-11 S 027	68108	37
S-2630	FD 200-19 310	64509	231
S-2694	9 10-19 P 355	64324	151
S-2734	FD 530-30 451	64590	259
S-2827	9 10-14 P 345	64258	94
S-2883	FD 330-22 318	64488	246
S-28929	9 10-14 P 959	67588	105
S-2924	9 10-16 P 353	64298	110
S-29892	10 10.5AV-16 P 1219	78239	185
S-3184	FD 530-22 316	64544	257
S-3467	11 10.5-21 A 313	64273	206
S-3518	FD 200-19 315	64510	231
S-3648	11 10.5-15 A 414	64424	188
S-3798	FD 330-30 370	64534	253
S-3830	11 10.5-21 A 313	64273	206
S-3839	11 10.5-15 A 415	64253	188
S-3842	9 10-19 P 357	64326	151
S-4041	9 10-16 A 310	70115	108
S-4041	9 10-16 P 310	64269	108
S-4771	11 10.5C-16 A 320	64254	191
S-5060	9 10-19 P 356	64325	151
S-5270	FD 200-19 315	64510	231
S-5468	FD 330-22 346	64492	248
S-6195	9 10-19 P 326	64323	150
S-6242	FD 330-30 340	64532	252
S-6412	FD 530-30 449	64589	259

MANUFACTURER	CT	No.	2 3
S-6861	FT 530-35 437	64577	278
S-7100	FT 530-35 455	64581	280
S-7128	11 10.5-21 A 370	64354	207
S-7193	9 9M-13 P 1181	75179	57
S-7853	FT 530-35 456	64582	280
S-8701	FD 200-25 428	64551	242
S-8768	FD 200-19 320	64267	232
S-8832	6 6.5-11 S 030	68111	33
S-8874	FT 530-35 457	64583	280
S-8988	9 10-19 P 438	64335	154
S-9346	6 6.5-13 S 038	68120	39
S-9830	FD 330-30 369	64533	252
SR1VA104	10 10.5AV-16 P 1222	78238	186
<b>Histeer</b>			
10300	FT 530-35 437	64577	278
10301	FT 530-35 441	64580	279
10302	FD 200-19 448	64512	232
10303	FT 330-29 434	64285	267
10303	FT 330-29 875	69641	274
10305	FD 200-19 450	64513	233
10307	FD 200-25 454	64554	243
10313	FT 330-29 554	66522	271
10315	FD 331-26 480	64284	256
10315	FD 331-26 541	64599	256
10316	FD 530-35 530	64604	261
<b>Holland Hitch</b>			
4514	FT 530-32 333	64505	276
<b>Hutchens</b>			
10384-01	FD 330-22 364	64494	248
19141-01	9 9-12 P 1476	79614	55
H-1913-1	9 10-14 P 335	64465	93
H-2007	9 9-12 A 334	64360	48
H-9360-01	9 10-16 A 310	70115	108
H-9360-01	9 10-16 P 310	64269	108
H-9424-01	9 10-10 P 311	64260	70
H-9424-03	9 10-10 P 311	64260	70
<b>Ikarus</b>			
	6S 9.5-15.5 (661 N)	68461	32
	6S 9.5-15.5 (661 N)	68461	32
	6S 9.5-15.5 (661 N)	68461	32
<b>International</b>			
1681579C1	9 10-19 A 946	67480	159
1681579C1	9 10-19 P 946	67479	159



MANUFACTURER	CT	No.	2	3
4731042000	6S 9.5-15.5 (661 N)	68461	32	
4731042000	6S 9.5-15.5 (661 N)	68461	32	
4731042000	6S 9.5-15.5 (661 N)	68461	32	
4731042000	6S 9.5-15.5 (661 N)	68461	32	
4731042000	6S 9.5-15.5 (661 N)	68461	32	
4731042000	6S 9.5-15.5 (661 N)	68461	32	
4731042000	6S 9.5-15.5 (661 N)	68461	32	
4731042000	6S 9.5-15.5 (661 N)	68461	32	
4731042000	6S 9.5-15.5 (661 N)	68461	32	
4771170000	5S 8-15.5 (644N)	66141	32	
4771170000	5S 8-15.5 (644N)	66141	32	
4771170000	5S 8-15.5 (644N)	66141	32	
4771170000	5S 8-15.5 (644N)	66141	32	
4771170000	5S 8-15.5 (644N)	66141	32	
4771170000	5S 8-15.5 (644N)	66141	32	
4771170000	5S 8-15.5 (644N)	66141	32	
4771170000	5S 8-15.5 (644N)	66141	32	
4771170000	5S 8-15.5 (644N)	66141	32	
4771170000	5S 8-15.5 (644N)	66141	32	
4771170000	5S 8-15.5 (644N)	66141	32	
4771170000	5S 8-15.5 (644N)	66141	32	
4771170000	5S 8-15.5 (644N)	66141	32	
4771170000	5S 8-15.5 (644N)	66141	32	
4771170000	5S 8-15.5 (644N)	66141	32	
4771170000	5S 8-15.5 (644N)	66141	32	
4771170000	5S 8-15.5 (644N)	66141	32	
4771170000	5S 8-15.5 (644N)	66141	32	
4771170000	5S 8-15.5 (644N)	66141	32	
4771170000	5S 8-15.5 (644N)	66141	32	
4771170000	5S 8-15.5 (644N)	66141	32	
4771170000	5S 8-15.5 (644N)	66141	32	
4771170000	5S 8-15.5 (644N)	66141	32	
4771170000	5S 8-15.5 (644N)	66141	32	
4771170000	5S 8-15.5 (644N)	66141	32	
4771170000	5S 8-15.5 (644N)	66141	32	
4771170000	5S 8-15.5 (644N)	66141	32	
4771427000	6S 9.5-15.5 (661 N)	68461	32	
4771427000	6S 9.5-15.5 (661 N)	68461	32	
4771440000	6S 9.5-15.5 (661 N)	68461	32	
4771441000	5S 8-15.5 (644N)	66141	32	
<b>Leland</b>				
SC2134	9 10-19 P 355	64324	151	
SC2464	9 10-19 P 321	64280	150	
<b>Link</b>				
1101-0023	SC29-OG13	78379	295	

MANUFACTURER	CT	No.	2	3
1101-0030	SC29-P116	601575	296	
1101-0045	SC29-YG14	78410	304	
1102-0023	SC29-O001	67770	290	
1102-0025	SC29-O086	67858	293	
1102-0027	SC29-O098	69924	293	
1102-0031	SC29-R080	78412	297	
1102-0041	SC29-W042	70020	298	
1102-0042	SC29-W045	69929	298	
1102-0043	SC29-W056	69930	299	
1102-0045	SC29-W074	69416	300	
1102-0046	SC29-W035	67851	297	
1102-0047	SC29-W074	69416	300	
1102-0048	SC29-W075	67859	300	
1102-0070	SC29-Y044	78413	302	
1102-0074	SC29-Y064	67768	302	
1102-0075	SC29-Y108	67852	303	
1102-0077	SC29-Y109	69624	303	
1102-0081	SC29-B083	78414	287	
1102-0082	SC29-B110	69437	288	
1102-0083	SC29-B092	67854	288	
1102-1001	SC29-YC07	75707	303	
1102-K023	SC29-O001	67770	290	
1102-K082	SC29-B110	69437	288	
1102-K083	SC29-B092	67854	288	
1103 0061	9 10-19 P 809	65396	157	
1103-0001	FT 530-35 441	64580	279	
1103-0002	FD 200-19 448	64512	232	
1103-0003	FT 330-29 722	64709	272	
1103-0019	FD 200-19 724	64712	236	
1103-0056	FT 330-29 723	64710	272	
1103-0057	FT 530-32 535	64507	277	
1103-0058	9 10-19 P 765	64711	156	
1103-0503	9 9-9 P 767	64713	45	
1103-0505	9 9-14 P 768	64714	61	
1103-0509	9 10-17.5 P 793	64756	136	
1104-K002	SC29-Y109	69624	303	
R81-1002	SC29-B110	69437	288	
R811001	SC29-O001	67770	290	
T811001	SC29-B092	67854	288	
<b>Lippert</b>				
156425	FD 70-13 796	66660	222	
156622	FD 120-20 795	66661	230	
156727	FD 200-22 765	66662	240	

MANUFACTURER	CT	No.	2	3
<b>Load Air</b>				
P10-754-U	FD 110-15 766	66094	228	
P10-755-C	FD 330-22 500	64501	251	
P10-872-A	FD 200-19 506	64518	234	
P60-733	11 10.5-17 A 388	64348	199	
<b>Loadguard</b>				
SC2010	FD 200-19 310	64509	231	
SC2010	FD 200-19 499	64515	233	
SC2010	FS 330-11 474	64596	216	
SC2011	FD 200-19 320	64267	232	
SC2012	FS 530-14 339	64521	217	
SC2013	FD 530-22 311	64543	257	
SC2014	FD 530-22 321	64545	257	
SC2015	FD 530-22 316	64544	257	
SC2016	FD 530-22 374	64548	258	
SC2017	FD 530-22 342	64546	258	
SC2018	FD 330-22 472	64500	250	
SC2019	FD 330-22 471	64499	250	
SC2020	FD 330-22 313	64270	245	
SC2021	FD 330-22 318	64488	246	
SC2022	FD 330-22 346	64492	248	
SC2023	FD 330-22 331	64268	246	
SC2024	FD 330-22 327	64283	246	
SC2025	FD 330-22 334	64489	247	
SC2026	FD 330-30 323	64531	252	
SC2027	FD 330-30 370	64534	253	
SC2028	FD 330-30 340	64532	252	
SC2029	FT 530-32 329	64504	276	
SC2029	FT 530-35 436	64576	278	
SC2030	FT 530-32 333	64505	276	
SC2031	FT 530-32 336	64506	277	
SC2032	FT 530-32 325	64503	276	
SC2033	9 10-10 P 311	64260	70	
SC2034	9 10-14 A 312	75626	92	
SC2034	9 10-14 P 312	64274	93	
SC2035	9 10-16 A 310	70115	108	
SC2035	9 10-16 P 310	64269	108	
SC2035	FD 200-19 450	64513	233	
SC2036	9 10-16 P 333	64294	109	
SC2038	9 10-19 P 315	64279	150	
SC2039	9 10-12 P 319	64445	78	
SC2040	11 10.5-17 A 317	64272	197	
SC2041	11 10.5-21 A 313	64273	206	

MANUFACTURER	CT	No.	2	3
SC2042	11 10.5-17 A 364	64343	197	
SC2043	11 10.5-17 A 365	64344	197	
SC2044	11 10.5-21 A 370	64354	207	
SC2045	11 10.5-21 A 318	64352	206	
SC2046	11 10.5-17 A 316	64342	196	
SC2046	FD 200-19 452	64514	233	
SC2047	11 10.5-15 A 414	64424	188	
SC2048	9 10-16 P 407	64262	113	
SC2048	9 10-16 P 441	64308	115	
SC2049	9 9-14 P 322	64378	60	
SC2050	9 9-12 P 314	64255	48	
SC2051	9 10-16 P 325	64292	108	
SC2052	11 10.5C-16 A 320	64254	191	
SC2070	9 10-16 P 408	64259	113	
SC2071	FD 200-19 315	64510	231	
SC2072	FD 200-25 453	64553	242	
SC2073	FD 330-22 364	64494	248	
SC2074	FD 330-22 367	64497	249	
SC2075	FD 330-22 363	64493	248	
SC2076	FD 330-22 365	64495	249	
SC2077	FD 330-22 343	64491	247	
SC2078	FD 330-30 372	64536	253	
SC2079	FD 530-30 451	64590	259	
SC2080	FD 530-22 345	64547	258	
SC2098	11 10.5-21 A 313	64273	206	
SC2101	FD 330-22 368	64498	250	
SC2102	9 10-19 P 321	64280	150	
SC2108	9 10-19 A 946	67480	159	
SC2108	9 10-19 P 946	67479	159	
SC2109	9 10-19 P 356	64325	151	
SC2110	9 9-12 P 379	64361	49	
SC2111	11 10.5-21 A 370	64354	207	
SC2112	11 10.5-17 A 365	64344	197	
SC2113	11 10.5-17 A 364	64343	197	
SC2115	11 10.5-21 A 318	64352	206	
SC2116	11 10.5-15 A 415	64253	188	
SC2119	FT 330-29 432	64563	267	
SC2120	9 10-19 P 326	64323	150	
SC2120	9 10-21 A 361	64715	162	
SC2120	9 10-21 A 505	64716	163	
SC2120	9 10-21 P 361	64291	163	
SC2120	9 10-21 P 505	64384	164	
SC2121	11 10.5C-16 A 378	64357	191	

MANUFACTURER	CT	No.	2 3
SC2122	FD 200-25 426	64549	241
SC2123	FD 200-25 429	64552	242
SC2124	FD 200-19 448	64512	232
SC2124	FD 200-25 454	64554	243
SC2125	FD 200-25 427	64550	241
SC2126	FD 200-25 463	64555	243
SC2127	FD 200-25 428	64551	242
SC2128	FD 330-30 371	64535	253
SC2129	FD 530-30 449	64589	259
SC2130	FD 330-22 540	64502	251
SC2130	FT 330-29 431	64562	266
SC2130	FT 330-29 469	64566	268
SC2131	FT 330-29 434	64285	267
SC2132	FT 330-29 503	64568	269
SC2134	9 10-19 P 390	64331	153
SC2135	FT 530-35 455	64581	280
SC2136	FT 530-35 457	64583	280
SC2175	9 10-16 P 410	64276	114
SC2457	9 10-12 A 327	64446	79
SC2464	9 10B-17.5 A 323	64371	140
SC2750	9 10S-16 S 382	77614	121
SC2750	9 10S-16 A 382	64266	120
SC2750	9 10S-16 P 382	67473	121
SC2751	FD 120-20 509	64601	229
SC2752	9 10-19 P 439	65356	154
SC2756	9 10-17.5 P 436	64401	130
SC2758	9 10-12 A 427	64395	81
SC2759	9 10-19 P 435	64288	153
SC2760	9 10-16 P 416 (BK)	69643	114
SC2761	10 10-21 P 434	64394	182
SC2762	9 10-16 A 310	70115	108
SC2762	9 10-16 P 310	64269	108
SC2762	FD 200-19 450	64513	233
SC2763	9 10-19 P 438	64335	154
SC2765	9 10-16 P 325	64292	108
SC2766	FD 200-19 362	64511	232
SC2767	9 10-16 P 372	64301	111
SC2769	9 10-14 P 461	64473	97
SC2770	9 10-18.5 P 406 (BK)	68615	144
SC2773	9 10-18.5 P 451 (BK)	68616	144
SC2774	9 10-21 P 360	64382	162
SC2775	9 10-14 A 330	64464	93
SC2778	11 10.5-17 A 367	64346	198

MANUFACTURER	CT	No.	2 3
SC2780	9 10-10 P 331	64431	71
SC2782	11 10.5-15 A 422	64428	189
SC2784	FT 330-29 525	64571	269
SC2785	9 10-10 P 339	64433	72
SC2786	9 10-16 P 352	64297	110
<b>Longer Stroke</b>			
8008	FT 330-29 554	66522	271
8018	FT 330-29 875	69641	274
<b>MAC</b>			
2380 Z1	FD 70-17 820	67700	224
2380 Z1 1/4	FD 70-15 738	64735	223
2380 Z1 3/8	FD 70-15 740	64737	223
2380 Z1-0	FD 70-15 733	64730	222
2380 Z14	FT 330-29 773	65978	272
2380 Z2	FD 110-19 815	67602	229
2380 Z2 1/4	FD 110-15 739	64736	225
2380 Z2 3/8	FD 110-15 741	64738	226
2380 Z2-0	FD 110-15 734	64731	224
2380 Z41	FD 70-15 744 (4ply)	64741	224
2380 Z42	FD 110-15 745 (4ply)	64742	226
2380 Z43	FD 70-15 742 (4ply)	64739	223
2380 Z44	FD 110-15 743 (4ply)	64740	226
2380 Z45	FD 110-15 746 (4ply)	64743	227
2380 Z5	FD 110-15 735	64732	225
2380 Z7	FD 120-20 736	64733	230
2380 Z9	FD 110-15 737	64734	225
<b>Mack</b>			
20910892	9 10S-17 P 1153 (BK)	74883	125
21244322	9 10S-17 P 1206	75561	126
21669088	9 10S-17 P 1206	75561	126
227QS312BM	SC29-BG07	78405	289
227QS32	FD 120-20 509	64601	229
227QS32	FD 330-22 364	64494	248
227QS33	SC29-O001	67770	290
227QS33	SC29-W035	67851	297
227QS34	SC29-R007	70014	296
227QS47M	SC29-BG08	78417	290
364QS28	9 10-16 P 410	64276	114
364SQ27	9 10-18.5 P 451 (BK)	68616	144
57QK1113	FD 120-20 509	64601	229
57QK1113	FD 330-22 364	64494	248
57QL1115	9 9M-13 P 1182	75180	57
57QL239	FD 530-22 374	64548	258

MANUFACTURER	CT	No.	2	3
57QL310	9 10-16 A 310	70115	108	
57QL310	9 10-16 P 310	64269	108	
57QL411M	9 10-16 P 410	64276	114	
57QL414M	9 10-18.5 P 451 (BK)	68616	144	
57QL417M	9 10-18.5 P 550 (BK)	69659	145	
57QL46	FD 530-22 311	64543	257	
57QL519M	9 10S-17 P 1153 (BK)	74883	125	
57QL53M	9 10-18.5 P 096 (BK)	68613	143	
57QL54M	9 10S-17 P 1154 (BK)	74884	126	
57QL55M	6 6.5B-11 P 236	69915	36	
57QL57M	9 10-18.5 P 939 (BK)	67573	146	
57QL59M	9 9K-12 P 093	68608	56	
<b>Magirus-Deutz</b>				
0249 8667	6S 9.5-15.5 (661 N)	68461	32	
0249 8667	6S 9.5-15.5 (661 N)	68461	32	
0249 8667	6S 9.5-15.5 (661 N)	68461	32	
0249 8667	6S 9.5-15.5 (661 N)	68461	32	
0249 8667	6S 9.5-15.5 (661 N)	68461	32	
0249 8667	6S 9.5-15.5 (661 N)	68461	32	
0249 8667	6S 9.5-15.5 (661 N)	68461	32	
0249 8667	6S 9.5-15.5 (661 N)	68461	32	
0249 8667	6S 9.5-15.5 (661 N)	68461	32	
0418 22247	6S 9.5-15.5 (661 N)	68461	32	
0418 22247	6S 9.5-15.5 (661 N)	68461	32	
0418 22247	6S 9.5-15.5 (661 N)	68461	32	
0418 22247	6S 9.5-15.5 (661 N)	68461	32	
0418 22247	6S 9.5-15.5 (661 N)	68461	32	
0445 6111	6S 9.5-13	70129	32	
<b>Mahowk</b>				
10132401	9 10-10 P 311	64260	70	
53-14006-002	9 9-14 A 337	64379	60	
82-17289-000	9 10-12 P 395	64451	80	
<b>MAN</b>				
81436010017	5S 8-15.5 (644N)	66141	32	
81436010059	6S 9.5-13	70129	32	
81436010060	6S 9.5-13	70129	32	
81436010061	6S 9.5-13	70129	32	
81436010075	6S 9.5-13	70129	32	
81436010078	6S 9.5-13	70129	32	
81436010081	6S 9.5-13	70129	32	
81436010083	6S 9.5-13	70129	32	
81436010090	6S 9.5-13	70129	32	
81436010113	6S 9.5-13	70129	32	
81436010115	6S 9.5-13	70129	32	
81436010117	6S 9.5-13	70129	32	

MANUFACTURER	CT	No.	2	3
81436010117	6S 9.5-13	70129	32	
81436010117	6S 9.5-13	70129	32	
81436010117	6S 9.5-13	70129	32	
81436010117	6S 9.5-13	70129	32	
81436010117	6S 9.5-13	70129	32	
81436010117	6S 9.5-13	70129	32	
90831120114	6S 9.5-15.5 (661 N)	68461	32	
90831120144	6S 9.5-15.5 (661 N)	68461	32	
90831120144	6S 9.5-15.5 (661 N)	68461	32	
90831120144	6S 9.5-15.5 (661 N)	68461	32	
90831120144	6S 9.5-15.5 (661 N)	68461	32	
90831120144	6S 9.5-15.5 (661 N)	68461	32	
90831120144	6S 9.5-15.5 (661 N)	68461	32	
<b>MB Tuerk</b>				
A 000 327 01 01	5S 8-15.5 (644N)	66141	32	
A 000 327 01 01	5S 8-15.5 (644N)	66141	32	
A 000 327 01 01	5S 8-15.5 (644N)	66141	32	
A 613 327 00 01	5S 8-15.5 (644N)	66141	32	
A 613 327 02 01	6S 9.5-15.5 (661 N)	68461	32	
<b>MCI</b>				
1622372C1	9 10-18.5 P 406 (BK)	68615	144	
2992101C1	11 10.5C-16 A 378	64357	191	
2992101C1	11 10.5C-16 A 380	64358	192	
2992101C1	9 10-18.5 P 519 (BK)	64265	144	
2K3-11	9 9-12 P 1155	74911	55	
393902468	9 9L-10 P 1150	74843	47	
<b>Mercedes</b>				
A 363 328 00 01	6S 9.5-13	70129	32	
A 363 328 00 01	6S 9.5-13	70129	32	
A 363 328 00 01	6S 9.5-13	70129	32	
A 363 328 00 01	6S 9.5-13	70129	32	
A 363 328 00 01	6S 9.5-13	70129	32	
A 363 328 00 01	6S 9.5-13	70129	32	
A 363 328 00 01	6S 9.5-13	70129	32	
A 363 328 00 01	6S 9.5-13	70129	32	
A 363 328 00 01	6S 9.5-13	70129	32	
A 363 328 01 01	6S 9.5-13	70129	32	
<b>Meritor</b>				
200041	9 10-19 A 358	64327	152	
200041	9 10-19 P 358	64615	152	
200041	9 10-19 P 383	64281	153	
200042	FD 200-19 310	64509	231	
200117	FT 330-29 466	64565	268	
200118	FD 200-25 454	64554	243	
200154	9 10-12 P 319	64445	78	

MANUFACTURER	CT	No.	2	3
200175	FS 530-14 517	64528	219	
200177	FT 530-35 441	64580	279	
200180	FD 200-25 463	64555	243	
200183	FD 200-19 506	64518	234	
200448	FD 330-22 318	64488	246	
200457	9 10-10 P 311	64260	70	
200458	11 10.5-15 A 415	64253	188	
200504	11 10.5-22 A 530	64422	209	
200792	FS 530-14 516	64527	219	
200807	FS 530-14 516	64527	219	
200981	FD 330-22 364	64494	248	
201150	9 10-10 S 221	69767	70	
201222	11 10.5-15 A 422	64428	189	
201339	FD 330-30 370	64534	253	
201364	FD 330-30 370	64534	253	
201377	FD 530-30 451	64590	259	
201498	FT 530-35 439	64579	279	
201531	11 10.5-15 A 420	64426	189	
201548	FD 200-19 499	64515	233	
201602	FD 330-30 502	64539	254	
201680	11 10.5C-16 A 320	64254	191	
201869	9 10-16 A 310	70115	108	
201869	9 10-16 P 310	64269	108	
202035	9 10-19 P 326	64323	150	
202219	9 10-16 P 332	64293	109	
202394	FT 330-29 434	64285	267	
202796	10 10A-12 P 1330	77963	168	
203022	FT 530-35 455	64581	280	
21208939	9 10-10 P 311	64260	70	
21216135	9 10-10 P 311	64260	70	
21227742	9 10-17.5 P 1388	78601	139	
21227742	9 10-17.5 P 831	65831	137	
21227892	9 10-17.5 P 779	64729	136	
2258C1459	9 10-12 P 543	64462	84	
2258G1489	FD 200-25 1008	75184	245	
2258N1470	9 10-10 S 221	69767	70	
A2258D1668	11 10.5B-16.5 P 279	79093	195	
A2258E1461	10 10A-12 P 1330	77963	168	
A2258F1410	10 10A-12 P 1330	77963	168	
A2258P1576	11 10.5A-16 P 523	64421	190	
S6002	11 10.5C-16 A 320	64254	191	
<b>Milsco</b>				
07067A	SC29-Y108	67852	303	

MANUFACTURER	CT	No.	2	3
<b>Monaco Coach</b>				
0180 4591	9 9-12 P 730	64664	53	
0180 6160	9 9-9 P 756	64700	44	
0180 7467	9 9-12 P 757	64701	53	
0180 7468	FD 200-25 717	64702	244	
0180 8670	9 9-12 P 786	64752	53	
14002	9 9-12 P 477	64365	50	
8108	9 9-12 P 477	64365	50	
8618	6 6.5B-11 S 035	68116	37	
8619	9 9-12 P 477	64365	50	
<b>National Seating</b>				
2112283	SC29-0055	69926	292	
2123403	SC29-0001	67770	290	
<b>Navistar/Fleetrite</b>				
1622372C1	9 10-18.5 P 406 (BK)	68615	144	
1660581C1	9 10-16 P 407	64262	113	
1660581C1	9 10-16 P 441	64308	115	
1660694C1	9 9-12 P 379	64361	49	
1670043C1	9 10-18.5 P 521 (BK)	69646	145	
1670073C1	9 10-18.5 P 521 (BK)	69646	145	
1672401C1	9 10-16 P 408	64259	113	
1675495C1	9 10-14 P 450	64472	96	
1681737C1	9 10-19 P 356	64325	151	
1681738C1	9 10-19 P 326	64323	150	
1681739C1	9 10-16 P 408	64259	113	
1681740C1	9 10-19 P 326	64323	150	
1681741C1	11 10.5-17 A 365	64344	197	
1681742C1	11 10.5-21 A 370	64354	207	
1681743C1	11 10.5-17 A 364	64343	197	
1681745C1	11 10.5-21 A 318	64352	206	
1681746C1	11 10.5-15 A 415	64253	188	
1681747C1	11 10.5C-16 A 378	64357	191	
1681748C1	11 10.5-21 A 313	64273	206	
1681750C1	FD 330-22 368	64498	250	
1681751C1	FD 330-30 371	64535	253	
1685174C1	11 10.5C-16 A 320	64254	191	
1685175C1	FD 200-19 315	64510	231	
1685176C1	FD 200-25 453	64553	242	
1685177C1	FD 330-22 364	64494	248	
1685178C1	FD 330-22 367	64497	249	
1685179C1	FD 330-22 363	64493	248	
1685180C1	FD 330-22 365	64495	249	
1685181C1	FD 330-22 343	64491	247	



MANUFACTURER	CT	No.	2	3
1685182C1	FD 330-30 372	64536	253	
1685183C1	FD 530-30 451	64590	259	
1685184C1	FD 530-22 345	64547	258	
1686386C1	9 10-16 P 441	64308	115	
1686386C1	9 10-18.5 P 521 (BK)	69646	145	
1R11-278	99-12 P 314	64255	48	
1R12-1054	9 10S-16 P 382	67473	121	
1R12-1056	9 10-18.5 P 519 (BK)	64265	144	
1R12-1057	9 10S-16 P 1068 (BK)	73770	122	
1R12-1058	9 10-19 P 472	64339	155	
1R12-1059	9 10S-17 P 1154 (BK)	74884	126	
1R12-1062	9 10-18.5 P 521 (BK)	69646	145	
1R12-1064	9 10S-16 S 382	77614	121	
1R12-1064	9 10S-16 A 382	64266	120	
1R13-246	11 10.5-21 A 313	64273	206	
1R13-247	10 10-21 P 434	64394	182	
1R13-249	10 10.5-15 P 460	64645	185	
1R13-250	10 10-16 P 526	64638	177	
1R14-241	11 10.5C-16 A 320	64254	191	
1R14-242	11 10.5A-16 P 523	64421	190	
2027297C1	9 10-17.5 P 467 (BK)	69649	131	
2027911C1	9 10S-16 P 1068 (BK)	73770	122	
2027911C2	9 10S-16 P 1068 (BK)	73770	122	
2027911C3	9 10S-16 P 1068 (BK)	73770	122	
2027912C1	99-12 P 206	69627	48	
2027913C1	9 10-14 P 461	64473	97	
2B9-490	FD 200-19 505	64517	234	
2B9-491	FD 200-19 499	64515	233	
350243C94	9 10S-18 P 1067 (BK)	73746	142	
350449C1	9 10-14 P 348	64468	95	
3541731C1	9 10S-18 P 1067 (BK)	73746	142	
3541732C1	9 10S-18 P 1066 (BK)	73745	142	
359519C1	9 10-14 P 347	65364	95	
3596112C1	9 10S-17 P 1152 (BK)	74882	125	
501159C2	9 10-16 P 407	64262	113	
501559C1	9 10-16 P 407	64262	113	
501559C1	9 10-16 P 441	64308	115	
501559C2	9 10-16 P 441	64308	115	
517096C91	9 10-16 P 372	64301	111	
517559C9	9 10-16 A 310	70115	108	
517559C9	9 10-16 P 310	64269	108	
554761C1	99-14 P 322	64378	60	
554762C1	99-12 P 314	64255	48	

MANUFACTURER	CT	No.	2	3
554763C1	9 10-16 P 333	64294	109	
554764C1	9 10-14 A 312	75626	92	
554764C1	9 10-14 P 312	64274	93	
554766C1	9 10-10 P 311	64260	70	
554768C1	9 10-19 P 315	64279	150	
554770C1	9 10-12 P 319	64445	78	
554771C1	9 10-16 P 325	64292	108	
554772C1	11 10.5-21 A 313	64273	206	
554773C1	11 10.5-17 A 317	64272	197	
554776C1	11 10.5-17 A 365	64344	197	
554777C1	11 10.5-21 A 370	64354	207	
554778C1	11 10.5-17 A 364	64343	197	
554779C1	11 10.5-17 A 316	64342	196	
554780C1	11 10.5-21 A 318	64352	206	
554781C1	11 10.5-15 A 414	64424	188	
554782C1	FS 530-14 339	64521	217	
554783C1	FD 200-19 320	64267	232	
554784C1	FD 200-19 310	64509	231	
554784C1	FD 200-19 499	64515	233	
554785C1	FD 330-22 327	64283	246	
554786C1	FD 330-30 323	64531	252	
554787C1	FD 330-22 318	64488	246	
554788C1	FD 330-22 313	64270	245	
554789C1	FD 330-22 334	64489	247	
554789C1	FD 330-22 337	64490	247	
554790C1	FD 330-30 340	64532	252	
554791C1	FD 330-30 370	64534	253	
554792C1	FD 330-22 331	64268	246	
554793C1	FD 330-22 346	64492	248	
554794C1	FD 330-22 472	64500	250	
554795C1	FD 330-22 471	64499	250	
554796C1	FD 530-22 374	64548	258	
554797C1	FD 530-22 342	64546	258	
554798C1	FD 530-22 321	64545	257	
554799C1	FD 530-22 316	64544	257	
554800C1	FD 530-22 311	64543	257	
554801C1	FT 530-32 336	64506	277	
554802C1	FT 530-32 329	64504	276	
554802C1	FT 530-35 436	64576	278	
554803C1	FT 530-32 325	64503	276	
554803C1	FT 530-35 437	64577	278	
554804C1	FT 530-32 333	64505	276	

MANUFACTURER	CT	No.	2	3
<b>Neoplan</b>				
1001 10 300	5S 8-15.5 (644N)	66141	32	
1001 10 300	5S 8-15.5 (644N)	66141	32	
1001 12 250	6S 9.5-15.5 (661 N)	68461	32	
1001 12 250	6S 9.5-15.5 (661 N)	68461	32	
1001 12 250	6S 9.5-15.5 (661 N)	68461	32	
1001 12 250	6S 9.5-15.5 (661 N)	68461	32	
1001 12 250	6S 9.5-15.5 (661 N)	68461	32	
1001 12 250	6S 9.5-15.5 (661 N)	68461	32	
1001 12 254	5S 8-15.5 (644N)	66141	32	
1001 12 254	5S 8-15.5 (644N)	66141	32	
1001 12 254	5S 8-15.5 (644N)	66141	32	
1001 12 254	5S 8-15.5 (644N)	66141	32	
1001 12 254	5S 8-15.5 (644N)	66141	32	
1001 12 254	5S 8-15.5 (644N)	66141	32	
1001 12 254	5S 8-15.5 (644N)	66141	32	
1001 12 254	5S 8-15.5 (644N)	66141	32	
1001 12 254	5S 8-15.5 (644N)	66141	32	
1101 63 45	6S 9.5-15.5 (661 N)	68461	32	
AA 10-01-001	6S 9.5-15.5 (661 N)	68461	32	
AA 10-01-001	6S 9.5-15.5 (661 N)	68461	32	
AA 10-01-001	6S 9.5-15.5 (661 N)	68461	32	
AA 10-01-001	6S 9.5-15.5 (661 N)	68461	32	
AA 10-01-001	6S 9.5-15.5 (661 N)	68461	32	
AA 10-01-001	6S 9.5-15.5 (661 N)	68461	32	
AA 10-01-001	6S 9.5-15.5 (661 N)	68461	32	
AA 10-01-001	6S 9.5-15.5 (661 N)	68461	32	
AA 10-01-001	6S 9.5-15.5 (661 N)	68461	32	
AA 10-01-001	6S 9.5-15.5 (661 N)	68461	32	
AA 10-01-001	6S 9.5-15.5 (661 N)	68461	32	
AA 10-01-001	6S 9.5-15.5 (661 N)	68461	32	
AA 10-01-001	6S 9.5-15.5 (661 N)	68461	32	
AA 10-01-001	6S 9.5-15.5 (661 N)	68461	32	
AA 10-01-001	6S 9.5-15.5 (661 N)	68461	32	
AA 10-01-001	6S 9.5-15.5 (661 N)	68461	32	
AA 10-01-001	6S 9.5-15.5 (661 N)	68461	32	
AA 10-01-001	6S 9.5-15.5 (661 N)	68461	32	
AA 10-01-001	6S 9.5-15.5 (661 N)	68461	32	
AA 10-01-001	6S 9.5-15.5 (661 N)	68461	32	
AA 10-01-001	6S 9.5-15.5 (661 N)	68461	32	
AA 10-01-001	6S 9.5-15.5 (661 N)	68461	32	
AA 10-01-001	6S 9.5-15.5 (661 N)	68461	32	
AA 10-01-001	6S 9.5-15.5 (661 N)	68461	32	
AA 10-01-001	6S 9.5-15.5 (661 N)	68461	32	
AA 10-01-001	6S 9.5-15.5 (661 N)	68461	32	
AA 10-01-001	6S 9.5-15.5 (661 N)	68461	32	
AA 10-01-001	6S 9.5-15.5 (661 N)	68461	32	
AA 10-01-300	5S 8-15.5 (644N)	66141	32	
<b>New Flyer</b>				
102221	9 9-14 P 1142	74767	62	
124011	9 10-14 P 1143	74768	105	
13	10 10-15 P 1140	74765	175	
14635	9 10-14 P 709	64632	102	

MANUFACTURER	CT	No.	2	3
15201	11 10.5-15 A 1141	74766	190	
200555	9 9-14 P 1144	74769	63	
201313	10 10U-13 P 189	69494	169	
201316	10 10U-13 P 189	69494	169	
204429	9 10-12 P 190	69495	78	
303734	9 9-14 P 191	69511	59	
55089	9 9-14 P 895	67492	62	
5920815	6 6.5-13 S 056	68136	42	
5973876	9 10-12 P 1145	74790	87	
5973877	6 6.5-13 S 056	68136	42	
5973923	6 6.5-13 S 056	68136	42	
5993113	6 6.5-13 S 056	68136	42	
6160104	6 6.5-11 S 052	68134	35	
65	9 10-14 P 188	69493	91	
65	9 10-14 P 220	69774	92	
65	9 10-14 P 709	64632	102	
9594	9 10-12 A 707	64633	85	
9594	9 10-12 P 707	69541	85	
99865	9 9-14 P 708	64631	61	
<b>Newlite</b>				
NS19016	9 10-12 P 484	64456	82	
<b>Novabus</b>				
G1012381	9 9K-15 P 1147	74792	67	
G1019358	9 9K-15 P 1147	74792	67	
G1076863	9 9K-15 P 1299	77618	67	
G5001706	9 9K-15 P 1147	74792	67	
N15558	9 9K-15 P 1147	74792	67	
N16374	9 9-14 P 1146	74791	63	
N21361	9 10-12 A 104	68638	77	
<b>Orion</b>				
101324014	9 10-10 P 311	64260	70	
80131522	9 9-14 P 053	68355	59	
80231503	9 10-10 P 717	64643	76	
<b>Oshkosh</b>				
3620210	11 10.5-19 A 557	65360	203	
8013	FT 330-29 432	64563	267	
RX-08-03	9 10D-21 A 555	64377	167	
<b>PACCAR</b>				
B81-6023	SK 125-101 P01	78360	307	
<b>Peerless</b>				
0550-00001	FD 330-22 363	64493	248	
0550-00010	11 10.5-17 A 365	64344	197	
0550-00015	FS 530-14 442	64523	218	

MANUFACTURER	CT	No.	2	3
0550-00030	FT 530-32 336	64506	277	
0550-00051	9 10-10 P 339	64433	72	
0550-00070	11 10.5-17 A 364	64343	197	
0550-00080	11 10.5-21 A 370	64354	207	
0550-00081	11 10.5-21 A 370	64354	207	
<b>Peterbilt</b>				
03-01649	9 10-14 A 312	75626	92	
03-01649	9 10-14 P 312	64274	93	
03-02038	9 10-14 A 312	75626	92	
03-02038	9 10-14 P 312	64274	93	
03-02456	9 10-14 A 312	75626	92	
03-02456	9 10-14 P 312	64274	93	
03-04759	9 10-14 A 312	75626	92	
03-04759	9 10-14 P 312	64274	93	
03-05107	9 10-16 P 352	64297	110	
03-06213	9 10-16 P 393	64306	112	
03-06746	9 10-14 A 312	75626	92	
03-06746	9 10-14 P 312	64274	93	
03-07111	9 10-16 P 393	64306	112	
03-07112	9 10-14 A 312	75626	92	
03-07112	9 10-14 P 312	64274	93	
03-07887	9 10-19 P 472	64339	155	
03-08716	9 10-19 P 898	66666	158	
03-10042	9 10-14 A 312	75626	92	
03-10042	9 10-14 P 312	64274	93	
20-19036	SC29-O155	75314	294	
29-02454	SC29-Y036	68162	301	
29-03200	SC29-Y036	68162	301	
29-06016	SC29-B093	75313	288	
301686	9 9M-13 P 1283	77202	58	
308424	9 9M-13 P 1283	77202	58	
C81-6000	9 10-14 P 577	65990	102	
R81-6003	SC29-O132	75315	294	
<b>Pezzani</b>				
AR-21-A	FD 530-22 311	64543	257	
<b>Porcupine</b>				
7142	FD 530-22 316	64544	257	
7818	FD 330-22 366	64496	249	
7818	FT 530-35 437	64577	278	
<b>Prevost</b>				
63-0044	9 9K-15 P 1147	74792	67	
63-0158	9 9K-15 P 1147	74792	67	
63-0173	FD 200-19 319	64271	231	

MANUFACTURER	CT	No.	2	3
63-0174	FD 200-19 320	64267	232	
63-0178	9 10-19 P 356	64325	151	
63-0179	9 9-12 P 1155	74911	55	
63-0188	6S 9.5-15.5 (661 N)	68461	32	
63-0194	9 9K-15 P 1147	74792	67	
630045	9 9M-13 P 1181	75179	57	
950208	SK 37-6 P02	74324	307	
<b>R&amp;S Truck</b>				
1027405	FD 200-19 320	64267	232	
1027505	FD 200-19 310	64509	231	
1027505	FD 200-19 499	64515	233	
1027519	FD 330-22 313	64270	245	
1027556	FD 530-22 321	64545	257	
1040201	FD 330-22 318	64488	246	
1082914	FD 330-30 370	64534	253	
1090023	11 10.5-17 A 317	64272	197	
1090201	FD 330-22 318	64488	246	
1090214	FD 530-22 316	64544	257	
1090215	FD 330-22 327	64283	246	
1090216	11 10.5-17 A 316	64342	196	
1090217	9 10-16 A 310	70115	108	
1090217	9 10-16 P 310	64269	108	
1090218	9 10-10 P 311	64260	70	
1090276	9 10-14 A 330	64464	93	
1090326	11 10.5-17 A 405	64349	199	
10907	9 10-19 A 946	67480	159	
10907	9 10-19 P 946	67479	159	
<b>R.V.I.</b>				
5 000 819 517	6S 9.5-13	70129	32	
750208	6S 9.5-15.5 (661 N)	68461	32	
<b>RABA</b>				
	6S 9.5-15.5 (661 N)	68461	32	
<b>Raydan</b>				
211-00-000	FD 330-30 705	64245	255	
211-00-005	FD 330-30 549	64542	255	
211-00-010	9 10-10 P 311	64260	70	
211-00-025	11 10.5-16.5 A 129	68792	194	
211-00-026	11 10.5-13 A 761	64707	187	
211-00-027	11 10.5-16.5 A 751	64689	194	
211-00-030	9 10-12 A 463	64454	81	
211-00-030	9 10-12 P 463	67577	82	
211-00-040	9 9-12 P 524	64369	52	
211-00-047	11 10.5-16.5 A 976	68534	195	

MANUFACTURER	CT	No.	2	3
211-00-050	11 10.5-13 A 168	72932	187	
211-00-250	11 10.5-13 A 168	72932	187	
211-00M-034 R01	9 10-12 A 848	66029	86	
211-00M-036	9 10-12 A 118	68660	78	
225-8Z1-508	9 10-12 A 463	64454	81	
225-8Z1-508	9 10-12 P 463	67577	82	
AL460	9 10-12 A 463	64454	81	
AL460	9 10-12 P 463	67577	82	
AL520	9 10-12 A 463	64454	81	
AL520	9 10-12 P 463	67577	82	
<b>Renault</b>				
5000819517	6S 9.5-13	70129	32	
<b>Reyco</b>				
12882-01	9 10-16 A 310	70115	108	
12882-01	9 10-16 P 310	64269	108	
12882-02	11 10.5-17 A 317	64272	197	
12883-01	9 10-19 P 315	64279	150	
12883-02	11 10.5-21 A 313	64273	206	
12884-01	9 10-16 P 409	64275	114	
12884-01	9 10-17.5 P 733	64670	136	
12884-01A	9 10-16 P 409	64275	114	
12884-01B	9 10-16 P 510	64318	116	
12906-01	FD 200-25 453	64553	242	
12906-02	FD 200-25 453	64553	242	
12928-01	9 10-14 P 345	64258	94	
17360-01	9 10-10 P 398	64436	72	
17360-01	9 10-10 P 471	64439	73	
17361-01	9 9-12 P 401	64362	49	
17636-01	9 10-19 P 438	64335	154	
18813-01	FD 331-26 480	64284	256	
19983-01	FD 530-35 530	64604	261	
20018-01	FD 331-26 480	64284	256	
20018-01L	FD 331-26 514	64597	256	
20074-01	9 10-10 P 397	64435	72	
20124-01	9 10-17.5 P 731 (BK)	64668	135	
20124-01A	9 10-17.5 P 731 (BK)	64668	135	
20124-01K	9 10-17.5 P 731 (BK)	64668	135	
20124-02	9 10-17.5 P 731 (BK)	64668	135	
20124-12	9 10-17.5 P 731 (BK)	64668	135	
20142-01	9 10-17.5 P 452	64404	131	
20142-01	9 10-17.5 P 732 (BK)	64669	135	
20142-01K	9 10-17.5 P 452	64404	131	
20142-01K	9 10-17.5 P 732 (BK)	64669	135	

MANUFACTURER	CT	No.	2	3
20437-01	9 10-10 P 481	64442	74	
20773-01	9 9K-12 P 100	68617	56	
20966-01	9 10-16 P 500	64317	116	
21054-01	9 9-12 P 478	64366	50	
21055-01	9 10-10 P 503	64444	75	
21598-01	9 10-10 P 480	64441	74	
22241-01	9 10-12 P 485	64457	83	
23377-01	9 10-10 P 542	64658	75	
23433-01	10 10-15 S 773	64725	174	
23521-01	9 10-19 P 552	64340	155	
23521-02	9 10-19 P 553	64341	156	
23631-01	11 10.5C-16 A 320	64254	191	
24520-01	9 10-21 P 360	64382	162	
24556-01	11 10.5-15 A 420	64426	189	
6248	9 10B-17.5 A 323	64371	140	
6424	11 10.5-17 A 317	64272	197	
700195-01	10 10-14 S 736	64625	169	
701784-01	FD 200-22 706	64665	239	
702614-01	9 10-16 P 1602	601539	119	
709668-01	9 9K-15 P 945 (BK)	67448	66	
710387-01	9 9K-15 P 417	64386	65	
710387-02	9 9K-15 P 079	68407	64	
710442-01	9 9K-15 P 049	68406	64	
93AR	FT 330-29 434	64285	267	
<b>Ridewell</b>				
1000001	9 10-19 A 830	65807	158	
1000002	11 10.5-24 S 712	64637	213	
1000006	11 10.5-19 A 960	67547	203	
1001R12584G	9 10-16 P 1240	75973	119	
1001R13-087	10 10-15 S 962	67600	174	
1001R13-097	10 10-15 S 962	67600	174	
1001R13109G	10 10-15 S 871	66340	174	
1001R13181G	10 10-16 S 1239	75972	178	
1002B09296G	FD 200-19 1148	77120	238	
1003535770C	9 9L-10 P 1150	74843	47	
1003585310C	6 6.5-11 S 030	68111	33	
1003585311C	6 6.5-11 S 031	68112	34	
1003585323C	6 6.5-11 S 032	68113	34	
1003585410C	6 6.5-13 S 446	68123	42	
1003585412C	6 6.5-13 S 041	68124	40	
1003585414C	6 6.5-13 S 042	68125	40	
1003586801C	FD 530-30 451	64590	259	
1003586805C	FD 530-30 532	64593	260	

MANUFACTURER	CT	No.	2 3
1003586850C	FD 330-22 540	64502	251
1003586897C	FD 200-19 505	64517	234
1003586900C	FD 200-19 319	64271	231
1003586902C	FD 200-19 310	64509	231
1003586905C	FD 200-19 315	64510	231
1003586908C	FD 200-19 362	64511	232
1003586910C	FD 200-19 320	64267	232
1003586932C	FD 200-19 452	64514	233
1003586945C	FD 200-25 427	64550	241
1003586946C	FD 200-25 463	64555	243
1003586947C	FD 200-25 428	64551	242
1003586948C	FD 200-25 429	64552	242
1003587009C	FS 330-11 468	64595	216
1003587104C	FS 530-14 446	64524	218
1003587112C	FS 530-14 339	64521	217
1003587123C	FD 530-22 345	64547	258
1003587135C	FD 530-22 311	64543	257
1003587136C	FD 530-22 321	64545	257
1003587140C	FD 530-22 316	64544	257
1003587145C	FD 530-22 374	64548	258
1003587146C	FD 530-22 342	64546	258
1003587180C	FD 330-22 363	64493	248
1003587181C	FD 330-22 472	64500	250
1003587183C	FD 330-22 471	64499	250
1003587400C	FD 330-22 313	64270	245
1003587403C	FD 330-22 318	64488	246
1003587404C	FD 330-22 346	64492	248
1003587406C	FD 330-22 365	64495	249
1003587410C	FD 330-22 331	64268	246
1003587424C	FD 330-22 327	64283	246
1003587429C	FD 330-22 343	64491	247
1003587437C	FD 330-22 334	64489	247
1003587443C	FD 330-30 323	64531	252
1003587444C	FD 330-30 369	64533	252
1003587446C	FD 330-30 370	64534	253
1003587447C	FD 330-30 340	64532	252
1003587473C	FD 330-30 372	64536	253
1003587483C	FD 330-30 373	64537	254
1003587781C	FD 530-35 545	64607	262
1003587796C	FT 530-32 536	64508	277
1003587800C	FT 530-32 333	64505	276
1003587808C	FT 530-32 336	64506	277
1003587818C	FT 530-32 325	64503	276

MANUFACTURER	CT	No.	2 3
1003587839C	FT 530-35 437	64577	278
1003587843C	FT 530-35 455	64581	280
1003587844C	FT 530-35 438	64578	279
1003587846C	FT 530-35 456	64582	280
1003588008C	FT 330-29 431	64562	266
1003588010C	FT 330-29 432	64563	267
1003588014C	FT 330-29 874	69630	273
1003588016C	FT 330-29 433	64564	267
1003588018C	FT 330-29 434	64285	267
1003588030C	FT 330-29 498	64567	268
1003588032C	FT 330-29 413	64560	266
1003588051C	11 10.5C-16 A 385	64359	192
1003588052C	11 10.5C-16 A 378	64357	191
1003588088C	11 10.5-15 A 419	64425	188
1003588201C	9 10-12 P 483	64455	82
1003588752C	10 10-15 S 518	64396	172
1003588753C	10 10-15 S 713	64639	173
1003588778C	11 10.5-17 A 507	64350	199
1003588782C	10 10-15 S 871	66340	174
1003588802C	9 10-14 P 469	64477	98
1003588803C	9 10-14 P 489	64478	98
1003588805C	9 10-14 P 462	64474	97
1003588806C	9 10-14 A 545	64486	101
1003588901C	9 9-12 P 464	64364	50
1003588919C	9 9-14 P 517	64381	60
1003588924C	9 10-16 P 497	64314	115
1003588930C	9 10-12 P 396	64452	81
1003588963C	9 10-10 P 473	64440	74
1003588986C	9 10-10 P 400	64438	73
1003588992C	6 6.5D-11 S 037	68118	38
1003589008C	9 10-14 P 344	64466	94
1003589010C	9 10-14 P 345	64258	94
1003589029C	9 10-10 P 399	64437	73
1003589031C	9 10-10 P 339	64433	72
1003589053C	9 10-12 A 327	64446	79
1003589059C	9 10-14 P 335	64465	93
1003589069C	9 10-14 A 312	75626	92
1003589069C	9 10-14 P 312	64274	93
1003589071C	9 10-14 P 349	64469	95
1003589073C	9 9M-13 P 1181	75179	57
1003589075C	9 9-12 A 334	64360	48
1003589077C	9 10-10 P 331	64431	71
1003589082C	9 10-16 A 310	70115	108

MANUFACTURER	CT	No.	2 3
1003589082C	9 10-16 P 310	64269	108
1003589083C	9 10-16 P 333	64294	109
1003589096C	9 10-16 P 325	64292	108
1003589101C	9 10-19 P 315	64279	150
1003589105C	9 10-12 P 319	64445	78
1003589118C	9 10-12 A 342	64449	80
1003589121C	11 10.5-17 A 317	64272	197
1003589122C	11 10.5-21 A 313	64273	206
1003589149C	11 10.5-17 A 365	64344	197
1003589158C	11 10.5-21 A 318	64352	206
1003589177C	11 10.5-17 A 316	64342	196
1003589192C	9 10-19 P 326	64323	150
1003589200C	11 10.5-15 A 415	64253	188
1003589203C	9 10-19 P 355	64324	151
1003589213C	9 10-16 P 441	64308	115
1003589218C	11 10.5-15 A 422	64428	189
1003589219C	9 10-16 P 408	64259	113
1003589223C	9 10-16 P 409	64275	114
1003589245C	9 10-19 P 390	64331	153
1003589250C	9 10D-21 A 324	64375	166
1003589252C	9 10D-21 A 363	64376	167
1003589270C	9 10-13.5 S 433	64287	89
1003589274C	9 10B-17.5 A 362	65359	140
1003589275C	9 10B-17.5 A 323	64371	140
1003589277C	11 10.5-15 A 420	64426	189
1003589290C	9 9M-13 P 1290	77427	59
1003589308C	9 10-10 P 398	64436	72
1003589320C	9 10-21 P 360	64382	162
1003589321C	9 10-21 A 361	64715	162
1003589321C	9 10-21 P 361	64291	163
1003589334C	9 10-10 P 482	64443	75
1003589370C	9 10-21 P 448	64383	163
1003589378C	9 9-12 P 447	64363	49
1003589387C	9 9-12 P 479	64367	51
1003589394C	9 10-19 A 358	64327	152
1003589394C	9 10-19 P 358	64615	152
1003589394C	9 10-19 P 383	64281	153
1003589415C	9 9-14 P 322	64378	60
1003589421C	9 9-12 P 705	64627	52
1003589422C	9 9-12 P 314	64255	48
1003589448C	9 9-12 P 563	64286	52
1003589467C	9 10-14 A 491	64480	99
1003589797C	9 10-14 A 496	64484	100

MANUFACTURER	CT	No.	2 3
1003589961C	11 10.5-17 A 367	64346	198
1003B12338G	FT 330-29 1007	75142	274
10089780C	9 10S-16 P 382	67473	121
1013589039C	9 10-10 P 311	64260	70
S1728C	FD 200-19 499	64515	233
S2061C	9 10-10 P 311	64260	70
S2683C	FD 330-30 323	64531	252
S3053C	11 10.5-21 A 313	64273	206
S4302C	FD 330-22 318	64488	246
S5828C	9 10-19 P 315	64279	150
S5844C	FT 330-29 432	64563	267
S740C	9 10-19 P 315	64279	150
Rowe Truck			
0027ASC2500	9 10-17.5 P 904	66700	138
0035ASC1600	FD 200-19 712	64685	235
0035ASC2500	FD 200-19 712	64685	235
0266ASC1600HL	11 10.5-17 A 208	69629	196
ASC1400HL	6 6.5B-11 S 027	68108	37
ASCS2000	6 6.5-11 S 028	68109	33
ASCT2500	9 10-17.5 P 904	66700	138
SAF Holland			
50857000	9 10-13.5 P 874	68151	
57005410	6 6.5-13 S 446	68123	42
57006801	FD 530-30 451	64590	259
57006803	FD 530-30 449	64589	259
57006902	FD 200-19 310	64509	231
57006905	FD 200-19 315	64510	231
57006910	FD 200-19 320	64267	232
57006927	FD 200-25 453	64553	242
57006941	FD 200-19 448	64512	232
57006947	FD 200-25 428	64551	242
57007123	FD 530-22 345	64547	258
57007136	FD 530-22 321	64545	257
57007140	FD 530-22 316	64544	257
57007145	FD 530-22 374	64548	258
57007180	FD 330-22 363	64493	248
57007181	FD 330-22 472	64500	250
57007183	FD 330-22 471	64499	250
57007325	FD 120-20 509	64601	229
57007401	FD 330-22 337	64490	247
57007403	FD 330-22 318	64488	246
57007404	FD 330-22 346	64492	248
57007405	FD 330-22 364	64494	248



MANUFACTURER	CT	No.	2	3
57007406	FD 330-22 365	64495	249	
57007409	FD 330-22 367	64497	249	
57007410	FD 330-22 331	64268	246	
57007429	FD 330-22 343	64491	247	
57007443	FD 330-30 323	64531	252	
57007446	FD 330-30 370	64534	253	
57007447	FD 330-30 340	64532	252	
57007472	FD 330-30 371	64535	253	
57007473	FD 330-30 372	64536	253	
57007798	FT 530-32 329	64504	276	
57007798	FT 530-35 436	64576	278	
57007800	FT 530-32 333	64505	276	
57007808	FT 530-32 336	64506	277	
57007818	FT 530-32 325	64503	276	
57007839	FT 530-35 437	64577	278	
57008008	FT 330-29 431	64562	266	
57008050	11 10.5C-16 A 320	64254	191	
57008052	11 10.5C-16 A 378	64357	191	
57009053	9 10-12 A 327	64446	79	
57009069	9 10-14 A 312	75626	92	
57009069	9 10-14 P 312	64274	93	
57009073	9 9M-13 P 1181	75179	57	
57009077	9 10-10 P 331	64431	71	
57009083	9 10-16 P 333	64294	109	
57009096	9 10-16 P 325	64292	108	
57009105	9 10-12 P 319	64445	78	
57009130	9 10-19 P 321	64280	150	
57009149	11 10.5-17 A 365	64344	197	
57009194	9 10-16 P 352	64297	110	
57009200	11 10.5-15 A 415	64253	188	
57009213	9 10-16 P 441	64308	115	
57009215	11 10.5-15 A 414	64424	188	
57009219	9 10-16 P 408	64259	113	
57009223	9 10-16 P 409	64275	114	
57009238	9 10-19 P 356	64325	151	
57009250	9 10D-21 A 324	64375	166	
57009275	9 10B-17.5 A 323	64371	140	
57009302	9 10-12 P 343	64450	80	
57009321	9 10-21 A 361	64715	162	
57009321	9 10-21 P 361	64291	163	
57009348	9 10-19 P 439	65356	154	
57009379	9 9-12 P 379	64361	49	
57009415	9 9-14 P 322	64378	60	

MANUFACTURER	CT	No.	2	3
57009421	9 9-12 P 705	64627	52	
57009422	9 9-12 P 314	64255	48	
90036258	9 10-17.5 P 779	64729	136	
90044197	11 10.5-21 A 318	64352	206	
90044199	9 10-10 P 311	64260	70	
90044200	9 10-16 A 310	70115	108	
90044200	9 10-16 P 310	64269	108	
90044201	9 10-19 P 315	64279	150	
90044647	9 10-16 A 310	70115	108	
90044647	9 10-16 P 310	64269	108	
90044701	9 10-19 P 315	64279	150	
90044702	11 10.5-17 A 317	64272	197	
90054060	11 10.5-17 A 317	64272	197	
90054218	9 10-19 P 315	64279	150	
90054234	9 10-10 P 311	64260	70	
90057057	6 6.5-13 S 041	68124	40	
90554043	11 10.5-21 A 313	64273	206	
90557001	FD 530-22 311	64543	257	
90557002	FS 330-11 468	64595	216	
90557003	11 10.5-17 A 316	64342	196	
90557005	11 10.5-21 A 318	64352	206	
90557006	9 10-16 A 310	70115	108	
90557006	9 10-16 P 310	64269	108	
90557007	9 10-16 P 332	64293	109	
90557008	9 10-19 P 315	64279	150	
90557009	9 10-19 P 315	64279	150	
90557010	11 10.5-17 A 317	64272	197	
90557011	9 10-10 P 311	64260	70	
90557014	FD 330-22 327	64283	246	
90557015	FD 330-22 334	64489	247	
90557016	FD 330-22 313	64270	245	
90557018	FD 330-22 313	64270	245	
90557019	11 10.5-17 A 317	64272	197	
90557020	11 10.5-21 A 313	64273	206	
90557023	9 10-10 P 311	64260	70	
90557024	FD 530-22 342	64546	258	
90557026	FS 530-14 339	64521	217	
90557027	9 10-16 A 310	70115	108	
90557027	9 10-16 P 310	64269	108	
90557028	FS 530-14 339	64521	217	
90557029	6 6.5D-11 S 525	68119	38	
90557030	9 9-12 A 334	64360	48	
90557031	9 10-16 P 372	64301	111	

MANUFACTURER	CT	No.	2 3
90557032	9 10-16 P 332	64293	109
90557033	9 10-16 A 310	70115	108
90557033	9 10-16 P 310	64269	108
90557034	6 6.5D-11 S 525	68119	38
90557035	9 10-16 P 332	64293	109
90557037	9 10-16 A 310	70115	108
90557037	9 10-16 P 310	64269	108
90557038	9 10-14 A 330	64464	93
90557039	FD 530-22 342	64546	258
90557041	FS 530-14 339	64521	217
90557043	9 10-19 P 315	64279	150
90557052	11 10.5-17 A 317	64272	197
90557054	9 10-16 A 310	70115	108
90557054	9 10-16 P 310	64269	108
90557069	11 10.5-21 A 318	64352	206
90557071	11 10.5-21 A 313	64273	206
90557075	9 10-16 A 310	70115	108
90557075	9 10-16 P 310	64269	108
90557076	11 10.5-21 A 313	64273	206
90557077	11 10.5-21 A 313	64273	206
90557078	11 10.5-17 A 317	64272	197
90557082	9 10-19 P 315	64279	150
90557083	11 10.5-17 A 317	64272	197
90557085	9 10-10 P 311	64260	70
90557086	9 10-19 P 326	64323	150
90557089	9 10-10 P 398	64436	72
90557090	9 10-14 A 330	64464	93
90557097	9 9-12 P 1292	77432	55
90557098	11 10.5C-16 A 380	64358	192
90557099	9 10-21 P 360	64382	162
90557101	9 10-16 P 351	64296	109
90557102	11 10.5-22 A 931	68159	211
90557103	11 10.5-22 S 750	64688	210
90557104	11 10.5-24 S 276	70118	212
90557105	9 10-14 P 381	64470	96
90557106	11 10.5-24 S 277	70119	213
90557107	9 10-10 S 221	69767	70
90557108	9 10-19 P 326	64323	150
90557109	9 10-19 P 326	64323	150
90557110	11 10.5-17 A 317	64272	197
90557111	11 10.5-19 A 432	64392	202
90557112	9 10-19 P 1138	74663	160
90557113	9 10-16 P 391	64304	112

MANUFACTURER	CT	No.	2 3
90557117	9 10-17.5 P 443	64402	130
90557118	9 10-17.5 P 429	64278	129
90557119	9 10-17.5 P 428	64399	129
90557120	9 9K-15 P 424	64388	65
90557121	9 9K-15 P 417	64386	65
90557122	9 9K-15 P 425	64389	66
90557124	9 10-16 P 392	64305	112
90557125	11 10.5-19 A 431	64391	202
90557126	9 10-19 P 470	64338	154
90557127	9 9K-15 P 423	64387	65
90557129	9 10-10 P 471	64439	73
90557129	9 10-10.5 P 883	67490	76
90557130	9 10-14 P 437	64471	96
90557131	9 10-14 P 437	64471	96
90557135	9 10-19 P 326	64323	150
90557136	9 10-19 P 326	64323	150
90557137	9 10-14 P 381	64470	96
90557138	9 10-17.5 P 426	64398	128
90557139	9 9K-15 P 425	64389	66
90557142	9 10-17.5 P 430	64400	129
90557143	9 10-17.5 P 475	64407	132
90557145	9 10-17.5 P 501 (BK)	69647	132
90557146	9 10-17.5 P 502 (BK)	69648	132
90557147	9 10-17.5 P 467 (BK)	69649	131
90557149	9 10-12 P 395	64451	80
90557150	9 9K-15 P 455	64390	66
90557152	9 10-17.5 P 445 (BK)	69650	130
90557155	11 10.5-17 A 377	64347	198
90557156	9 10-17.5 P 454	64405	131
90557157	9 10-17.5 P 548	64412	133
90557158	9 10-14 P 494	64483	100
90557159	9 10-12 P 495	64460	84
90557160	9 10-12 P 488	64459	83
90557161	9 10-14 P 492 (BK)	69651	99
90557162	11 10.5-19 A 509	64289	203
90557163	11 10.5-19 A 508	64393	202
90557164	11 10.5-17 A 507	64350	199
90557166	9 10-14 P 493	64482	99
90557167	10 10-21 P 570	64252	183
90557168	10 10-21 P 486	64419	182
90557169	9 10-17.5 P 536	64423	133
90557170	9 10-14 P 469	64477	98
90557173	9 10-12 P 484	64456	82



MANUFACTURER	CT	No.	2	3
90557177	9 10-17.5 P 502 (BK)	69648	132	
90557178	9 10-17.5 P 467 (BK)	69649	131	
90557179	9 10-17.5 P 445 (BK)	69650	130	
90557181	9 10-17.5 P 467 (BK)	69649	131	
90557182	9 10-17.5 P 502 (BK)	69648	132	
90557184	9 10-14 P 494	64483	100	
90557185	11 10.5-21 A 313	64273	206	
90557189	9 10-14 P 489	64478	98	
90557194	9 10-14 P 489	64478	98	
90557195	9 10-14 P 534	78183	100	
90557200	11 10.5-22 A 530	64422	209	
90557203	FD 530-35 543	64605	261	
90557205	11 10.5-19 A 557	65360	203	
90557206	9 10B-17.5 P 554 (BK)	69652	140	
90557208	9 10-16 P 547 (BK)	69653	116	
90557209	11 10.5-15 A 422	64428	189	
90557210	9 10-12 P 488	64459	83	
90557210	9 10-12 P 543	64462	84	
90557211	9 10-17.5 P 501 (BK)	69647	132	
90557211	9 10-17.5 P 571	64415	134	
90557212	9 10-17.5 P 572 (BK)	69662	134	
90557213	9 10-17.5 P 573 (BK)	70335	134	
90557214	9 10-17.5 P 572 (BK)	69662	134	
90557215	9 10-17.5 P 445 (BK)	69650	130	
90557216	9 10-17.5 P 574 (BK)	69654	135	
90557218	11 10.5-22 S 1009	70771	211	
90557219	9 10-14 P 492 (BK)	69651	99	
90557223	9 10-12 P 484	64456	82	
90557225	9 10-12 P 488	64459	83	
90557226	FS 330-11 474	64596	216	
90557227	9 10-17.5 A 535	64411	133	
90557228	FD 200-19 539	64520	235	
90557230	9 10-12 P 024	68009	77	
90557235	10 10-21 P 774	64728	183	
90557236	FT 330-29 790	69747	273	
90557237	FD 200-25 426	64549	241	
90557243	10 10-21 P 964	67624	184	
90557252	9 10-18.5 P 551	64414	145	
90557256	9 10-12 P 720	64646	85	
90557257	FD 530-22 316	64544	257	
90557260	11 10.5-21 A 025	68010	205	
90557275	9 10-14 PT75 (BK)	64621	106	
90557288	10 10-21 P 570	64252	183	

MANUFACTURER	CT	No.	2	3
90557289	10 10-21 P 486	64419	182	
90557290	9 10SW-14 S 1574 (BK)	600932	107	
90557293	11 10.5C-16 A 378	64357	191	
90557300	9 10-17.5 P 454	64405	131	
90557301	9 10-17.5 P 548	64412	133	
90557301	9 10P-18.5 P 886	67491	148	
90557302	9 10-17.5 P 023	68158	126	
90557303	9 10-10 P 717	64643	76	
90557306	9 10-12 P 839	66117	86	
90557313	9 10-14 P 718 (BK)	64644	102	
90557316	9 10-17.5 P 807 (BK)	64767	137	
90557321	9 10-14 P 1359	78328	106	
90557322	9 9-14 P 737	78232	61	
90557323	11 10.5-17 A 377	64347	198	
90557324	11 10.5-17 A 317	64272	197	
90557325	9 10-10 P 717	64643	76	
90557329	9 10-14 P 882	66521	103	
90557331	9 10P-16.5 A 926	68155	124	
90557332	9 10-17.5 A 930	67586	138	
90557343	9 9J-20 P 776	78234	69	
90557344	9 10P-19 P 1362	78230	161	
90557345	11 10.5D-21 S 788	78170	208	
90557346	9 9K-12 P 790	64754	56	
90557347	9 10LP-17.5 P 806 (BK)	65540	141	
90557351	9 10LP-17.5 P 815 (BK)	65537	141	
90557358	9 10-17.5 P 571	64415	134	
90557361	9 9-12 P 835	65908	54	
90557364	9 9A-20 P 1363	78233	68	
90557366	FD 200-20 785	67706	238	
90557367	9 10-14 P 882	66521	103	
90557368	9 10-17.5 P 892 (BK)	78179	138	
90557369	9 10P-18.5 A 888	68156	148	
90557369	9 10P-18.5 P 195	77391	147	
90557370	10 10-21 P 949	67507	183	
90557371	9 9-12 P 974	67870	54	
90557372	9 10-13.5 P 874	68151	89	
90557373	9 10P-16.5 A 926	68155	124	
90557374	9 10P-18.5 A 998	78227	148	
90557375	9 10-13.5 P 978	68152	90	
90557376	9 10-19 P 901	78223	158	
90557377	9 10-21 P 900	77809	165	
90557379	9 10-12 P 022	78334	77	
90557384	11 10.5-22 A 020	78333	209	

MANUFACTURER	CT	No.	2 3
90557389	9 10-19 A 084	78224	149
90557392	11 10.5-17 A 133	77754	195
90557393	9 10-17.5 P 169	74205	127
90557394	11 10.5-17 A 170	78165	196
90557395	9 10-17.5 P 173	78181	127
90557396	9 10-17.5 P 175	78220	128
90557397	10 10K-13 P 163	78164	168
90557398	10 10K-14 P 167	78316	170
90557399	10 10K-15 P 164	78317	176
90557400	10 10B-14 P 165	78314	170
90557401	10 10B-15 P 166	78315	175
90557402	10 10B-16 P 162	78163	179
90557403	9 10P-16.5 P 194	78226	123
90557404	9 10P-18.5 P 195	77391	147
90557407	9 10-17.5 P 136 (BK)	78015	127
90557409	11 10.5E-18 A 213	69690	201
90557410	11 10.5E-16 A 214	69701	194
90557411	9 9-12 P 937 (BK)	68675	54
90557412	6 6.5F-15 S 211	78171	43
90557413	9 10-10.5 P 122 (BK)	78172	76
90557414	10 10.5-15 P 1036	78139	185
90557415	10 10-21 P 1000	78161	184
90557416	10 10-21 P 299	78162	182
90557418	9 10-14 P 297	78176	92
90557422	11 10.5-19 A 1047	78166	204
90557423	FD 530-35 912	78235	262
90557424	FT 530-35 924	78236	283
90557425	9 10-17.5 P 1056	78221	139
90557426	9 10-14 P 1029	78177	105
90557428	9 10C-13.5 P 1082	78225	91
90557429	9 10P-18.5 P 1113	78228	149
90557430	10 10K-20 P 1114	78331	181
90557431	10 10A-16 P 1106	78311	179
90557432	10 10A-16 P 1105	78312	179
90557433	10 10A-16 P 1102	78313	178
90557435	9 10-14 P 1189	78178	106
90557452	9 10P-18.5 P 1207	78229	149
90557455	10 10A-16 P 1106	78311	179
90557458	10 10K-15 P 1033	78318	176
90557459	10 10K-15 P 1034	78319	176
90557460	10 10K-15 P 1035	78330	177
90557461	10 10K-20 P 1059	78332	181
AR11151F	11 10.5-17 A 316	64342	196

MANUFACTURER	CT	No.	2 3
AR12151F	11 10.5-21 A 318	64352	206
AR12151G	11 10.5-21 A 313	64273	206
AS-0170	9 10-17.5 P 502 (BK)	69648	132
XDSPN05360	9 10-12 P 484	64456	82
<b>Sauer</b>			
P10-754	FD 120-20 509	64601	229
P10-755	FD 330-22 327	64283	246
P10-755C	FD 330-22 500	64501	251
P10-784	FD 330-22 365	64495	249
P10-784	FD 330-22 368	64498	250
P10-872A	FD 200-19 506	64518	234
P50-705	9 10-12 P 319	64445	78
P50-732	11 10.5-21 A 313	64273	206
P50-733	11 10.5-17 A 317	64272	197
P50-733A	FD 200-19 499	64515	233
P50-733B	9 10-16 A 354	64299	110
P50-734	9 10-10 P 311	64260	70
P60-733	11 10.5-17 A 388	64348	199
PB10-784	FD 330-30 371	64535	253
<b>Scania</b>			
	6S 9.5-13	70129	32
	6S 9.5-13	70129	32
	6S 9.5-13	70129	32
	6S 9.5-13	70129	32
	6S 9.5-13	70129	32
	6S 9.5-13	70129	32
	6S 9.5-13	70129	32
	6S 9.5-13	70129	32
412418	9 10-12 P 319	64445	78
660251	9 9M-13 P 1182	75180	57
670199	FD 330-22 313	64270	245
<b>Schmitz</b>			
750 208	6S 9.5-15.5 (661 N)	68461	32
<b>Sears</b>			
S-20235	SC29-W035	67851	297
S-9383	SC29-W035	67851	297
S13384	SC29-O150	70021	294
S5388	SC29-O040	70019	290
S8645	SC29-O041	69417	291
<b>Seats</b>			
200117	FT 330-29 466	64565	268
200175	FS 530-14 517	64528	219
200807	FS 530-14 516	64527	219
201642	10 10-15 S 518	64396	172

MANUFACTURER	CT	No.	2	3
707338	SC29-0040	70019	290	
<b>Silent Drive</b>				
AS-65906	11 10.5C-16 A 834	65906	193	
AS-6882	FD 200-19 315	64510	231	
AS-6948	FD 200-25 429	64552	242	
AS-7446	FD 330-30 370	64534	253	
AS-7800	FT 530-32 333	64505	276	
AS-7818	FT 530-32 325	64503	276	
AS-7848	FT 530-35 439	64579	279	
AS-8025	FT 330-29 469	64566	268	
AS-8919	9 9-14 P 517	64381	60	
AS-9070	9 10-14 A 330	64464	93	
AS-9082	9 10-16 A 310	70115	108	
AS-9082	9 10-16 P 310	64269	108	
AS-9320	9 10-21 P 360	64382	162	
AS-9362	9 10-16 P 391	64304	112	
AS-9649	9 10-18.5 P 551	64414	145	
<b>SMB</b>				
	5S 8-15.5 (644N)	66141	32	
<b>Spring Valley</b>				
AB-1000AL	9 10-19 P 315	64279	150	
AS-4315	FD 200-19 315	64510	231	
AS-4413	FT 330-29 413	64560	266	
AS-4426	FD 200-25 426	64549	241	
AS-4429	FD 200-25 429	64552	242	
AS-4434	FT 330-29 434	64285	267	
AS-4441	FT 530-35 441	64580	279	
AS-8310	9 10-16 A 310	70115	108	
AS-8310	9 10-16 P 310	64269	108	
AS-8315	9 10-19 P 315	64279	150	
AS-8319	9 10-12 P 319	64445	78	
AS-8333	9 10-16 P 333	64294	109	
AS-8713	10 10-15 S 713	64639	173	
<b>Strong</b>				
72404004	FS 330-11 771	66091	217	
<b>Suspension Dynamics</b>				
55015	9 10-10 S 221	69767	70	
630045	9 9M-13 P 1181	75179	57	
630158	9 9K-15 P 1147	74792	67	
630173	FD 200-19 319	64271	231	
630174	FD 200-19 320	64267	232	
630194	9 9K-15 P 1147	74792	67	

MANUFACTURER	CT	No.	2	3
<b>Suspensions, Inc.</b>				
200041	9 10-19 A 358	64327	152	
200041	9 10-19 A 946	67480	159	
200041	9 10-19 P 358	64615	152	
200041	9 10-19 P 383	64281	153	
200041	9 10-19 P 946	67479	159	
200042	FD 200-19 310	64509	231	
200042	FD 200-19 499	64515	233	
200117	FT 330-29 466	64565	268	
200118	FD 200-19 448	64512	232	
200118	FD 200-25 454	64554	243	
200175	FS 530-14 517	64528	219	
200177	FT 530-35 441	64580	279	
200180	FD 200-25 463	64555	243	
200457	9 10-10 P 311	64260	70	
200458	11 10.5-15 A 415	64253	188	
200620	FD 330-22 500	64501	251	
200620	FT 330-29 503	64568	269	
200792	FS 530-14 516	64527	219	
200835	FD 200-25 426	64549	241	
200981	FD 330-22 364	64494	248	
201150	9 10-10 S 221	69767	70	
201222	11 10.5-15 A 422	64428	189	
201335	9 10-21 A 505	64716	163	
201335	9 10-21 P 505	64384	164	
201498	FT 530-35 439	64579	279	
201602	FD 330-30 502	64539	254	
201642	10 10-15 S 518	64396	172	
201869	9 10-16 A 310	70115	108	
201869	9 10-16 P 310	64269	108	
202394	FT 330-29 434	64285	267	
202796	10 10A-12 P 1330	77963	168	
<b>Taurus</b>				
AS103-9073	9 9M-13 P 1181	75179	57	
AS214-7180	FD 330-22 363	64493	248	
AS214-7181	FD 330-22 472	64500	250	
AS214-7183	FD 330-22 471	64499	250	
AS214-7400	FD 330-22 313	64270	245	
AS214-7403	FD 330-22 318	64488	246	
AS214-7404	FD 330-22 346	64492	248	
AS214-7405	FD 330-22 364	64494	248	
AS214-7406	FD 330-22 365	64495	249	
AS214-7409	FD 330-22 367	64497	249	



MANUFACTURER	CT	No.	2	3
624319-610	5S 8-15.5 (644N)	66141	32	
624319-610	5S 8-15.5 (644N)	66141	32	
624319-610	5S 8-15.5 (644N)	66141	32	
624319-610	5S 8-15.5 (644N)	66141	32	
624319-610	5S 8-15.5 (644N)	66141	32	
624319-610	5S 8-15.5 (644N)	66141	32	
624319-610	5S 8-15.5 (644N)	66141	32	
624319-610	5S 8-15.5 (644N)	66141	32	
624319-610	5S 8-15.5 (644N)	66141	32	
624319-610	5S 8-15.5 (644N)	66141	32	
624319-610	5S 8-15.5 (644N)	66141	32	
624319-610	5S 8-15.5 (644N)	66141	32	
624319-610	5S 8-15.5 (644N)	66141	32	
624319-670	6S 9.5-15.5 (661 N)	68461	32	
624319-690	6S 9.5-15.5 (661 N)	68461	32	
624319-690	6S 9.5-15.5 (661 N)	68461	32	
624319-690	6S 9.5-15.5 (661 N)	68461	32	
624319-690	6S 9.5-15.5 (661 N)	68461	32	
624319-700	6S 9.5-15.5 (661 N)	68461	32	
<b>VDL Bus</b>				
0 659 561	6S 9.5-13	70129	32	
0 689 677	5S 8-15.5 (644N)	66141	32	
0 689 677	5S 8-15.5 (644N)	66141	32	
<b>Volvo</b>				
1 134 445	5S 8-15.5 (644N)	66141	32	
1 134 445	5S 8-15.5 (644N)	66141	32	
1 134 445	5S 8-15.5 (644N)	66141	32	
1 134 445	5S 8-15.5 (644N)	66141	32	
1 134 445	5S 8-15.5 (644N)	66141	32	
1 134 445	5S 8-15.5 (644N)	66141	32	
1 134 445	5S 8-15.5 (644N)	66141	32	
1 134 445	5S 8-15.5 (644N)	66141	32	
1 137 882	6S 9.5-15.5 (661 N)	68461	32	
1 137 888	6S 9.5-15.5 (661 N)	68461	32	
1 137 888	6S 9.5-15.5 (661 N)	68461	32	
1 137 888	6S 9.5-15.5 (661 N)	68461	32	
1 137 888	6S 9.5-15.5 (661 N)	68461	32	
1 137 888	6S 9.5-15.5 (661 N)	68461	32	
1 137 888	6S 9.5-15.5 (661 N)	68461	32	
1 199 893	5S 8-15.5 (644N)	66141	32	
1 593 842	6S 9.5-15.5 (661 N)	68461	32	
1 622 111	5S 8-15.5 (644N)	66141	32	
20 480 202	6602 N P02	74915	43	
20 573 113	6602 N P02	74915	43	
20 573 312	6603 N P01	74916	44	
20396293	9 10S-17 P 1154 (BK)	74884	126	

MANUFACTURER	CT	No.	2	3
20413888	9 10S-17 P 1154 (BK)	74884	126	
20462934	6 6.5B-11 P 236	69915	36	
20462941	9 9K-12 P 093	68608	56	
20505399	9 10S-17 P 1154 (BK)	74884	126	
20733034	9 10S-17 P 1153 (BK)	74883	125	
2076095	FD 330-22 337	64490	247	
20897204	6 6.5B-11 P 236	69915	36	
21 041 697	6602 N P02	74915	43	
21 041 697	6602 N P02	74915	43	
21 097 453	6602 N P02	74915	43	
21132004	9 10S-17 P 1206	75561	126	
21132005	9 10S-17 P 1206	75561	126	
25173616	9 10-18.5 P 095 (BK)	68612	142	
25173621	9 10-18.5 P 096 (BK)	68613	143	
3 159 252	5S 8-15.5 (644N)	66141	32	
3 171 693	6603 N P01	74916	44	
3 178 706	6603 N P01	74916	44	
3 195 240	6603 N P01	74916	44	
3 195 253	6S 9.5-15.5 (661 N)	68461	32	
3130488	FD 330-22 313	64270	245	
3130489	FD 530-22 321	64545	257	
3130490	9 10-19 P 315	64279	150	
3130491	9 10-16 A 310	70115	108	
3130491	9 10-16 P 310	64269	108	
3130492	9 10-10 P 311	64260	70	
3130494	11 10.5-17 A 316	64342	196	
3130495	9 10-16 P 441	64308	115	
3130498	11 10.5C-16 A 320	64254	191	
3130499	11 10.5-21 A 318	64352	206	
3130500	11 10.5-21 A 313	64273	206	
3130501	FD 530-22 311	64543	257	
3130503	11 10.5-17 A 317	64272	197	
3130504	FD 330-22 327	64283	246	
3180673	9 10-16 P 1309	77699	119	
350033201	9 10-16 P 408	64259	113	
350033203	9 10-16 P 408	64259	113	
350033204	9 10-16 P 408	64259	113	
350033209	9 10-16 P 408	64259	113	
350034409	9 10-16 P 410	64276	114	
352033204	FD 530-22 374	64548	258	
352033205	FD 530-22 374	64548	258	
352035001	FD 330-22 318	64488	246	
3522233203	9 10-16 P 408	64259	113	

MANUFACTURER	CT	No.	2	3
3934699	9 10S-17 P 1154 (BK)	74884	126	
660003-3201	SC31-OG11	78422	305	
6885533	6S 9.5-13	70129	32	
70 313 734	6602 N P02	74915	43	
70 321 079	6602 N P02	74915	43	
70 397 453	6602 N P02	74915	43	
8061151	9 10-16 P 416 (BK)	69643	114	
8079902	9 10S-17 P 1154 (BK)	74884	126	
8083871	9 10-18.5 P 095 (BK)	68612	142	
8084296	9 10S-17 P 1154 (BK)	74884	126	
8097092	9 10S-17 P 1154 (BK)	74884	126	
8169029	SC31-BG12	78423	305	
8169868	9 10-16 P 416 (BK)	69643	114	
85101145	9 10-14 A 312	75626	92	
85101145	9 10-14 P 312	64274	93	
85101146	FD 200-19 315	64510	231	
85101147	9 10-13.5 S 433	64287	89	
85101148	99-12 P 314	64255	48	
85101149	9 10-19 P 315	64279	150	
85101151	9 10S-16 S 382	77614	121	
85101151	9 10S-16 A 382	64266	120	
85101151	9 10S-16 P 382	67473	121	
85101153	9 10-10 P 311	64260	70	
85101155	9 10-19 P 435	64288	153	
85101156	9 10-16 P 407	64262	113	
85101157	9 10-16 P 410	64276	114	
85101158	FD 330-22 331	64268	246	
85101159	11 10.5-17 A 317	64272	197	
85101160	9 10-21 A 361	64715	162	
85101160	9 10-21 P 361	64291	163	
85101163	11 10.5-21 A 313	64273	206	
<b>Warren</b>				
8030120	FD 200-19 362	64511	232	
8030170	FT 530-32 336	64506	277	
<b>Watson &amp; Chalin</b>				
AS-0001	FD 200-19 320	64267	232	
AS-0002	FD 200-19 310	64509	231	
AS-0003	FD 330-22 313	64270	245	
AS-0004	FD 530-22 321	64545	257	
AS-0005	FD 330-30 370	64534	253	
AS-0006	FT 530-32 329	64504	276	
AS-0007	FD 330-22 318	64488	246	
AS-0008	FD 530-22 316	64544	257	

MANUFACTURER	CT	No.	2	3
AS-0009	FD 330-22 327	64283	246	
AS-0010	11 10.5-17 A 316	64342	196	
AS-0011	9 10-16 A 310	70115	108	
AS-0011	9 10-16 P 310	64269	108	
AS-0012	9 10-10 P 311	64260	70	
AS-0013	10 10-16.5 S 783	64746	180	
AS-0013	11 10.5-17 A 317	64272	197	
AS-0014	FD 330-22 337	64490	247	
AS-0015	9 10-12 P 319	64445	78	
AS-0017	99-12 P 314	64255	48	
AS-0018	9 10-16 P 333	64294	109	
AS-0019	FT 330-29 469	64566	268	
AS-0019-1F	FT 330-29 546	64572	270	
AS-0020	FD 200-19 315	64510	231	
AS-0021	FD 530-30 451	64590	259	
AS-0023	11 10.5-21 A 313	64273	206	
AS-0023-1G	11 10.5-21 A 062	68589	205	
AS-0025	FT 530-32 325	64503	276	
AS-0026	6 6.5D-11 S 525	68119	38	
AS-0027	FD 330-30 323	64531	252	
AS-0028	9 10-16 P 333	64294	109	
AS-0029	6 6.5-13 S 446	68123	42	
AS-0030	FD 120-20 509	64601	229	
AS-0032	FD 530-35 544	64606	261	
AS-0033	FT 530-35 437	64577	278	
AS-0034	FD 530-30 519	64592	260	
AS-0035	FD 200-19 362	64511	232	
AS-0036	9 10-21 P 361	64291	163	
AS-0036-G	9 10-21 A 361	64715	162	
AS-0038	9 10-19 P 326	64323	150	
AS-0039	11 10.5C-16 A 320	64254	191	
AS-0039	11 10.5CT-16 A 943	67442	193	
AS-0040	9 10-19 P 315	64279	150	
AS-0040-1F	9 10-19 P 315	64279	150	
AS-0041	FD 200-25 426	64549	241	
AS-0042	99L-10 P 1150	74843	47	
AS-0043	9 10-16 P 394	64307	113	
AS-0044	9 10-14 P 345	64258	94	
AS-0046	9 10-19 P 326	64323	150	
AS-0047	11 10.5-22 A 530	64422	209	
AS-0047-1G	11 10.5-22 A 752	64690	210	
AS-0047-F	11 10.5-22 A 530	64422	209	
AS-0047-G	11 10.5-22 A 752	64690	210	

MANUFACTURER	CT	No.	2 3
AS-0048	FT 330-29 703	64648	271
AS-0048-1F	FT 330-29 547	64573	270
AS-0048-2G	FT 330-29 703	64648	271
AS-0049	9 10-16 P 391	64304	112
AS-0050	9 10-14 A 330	64464	93
AS-0053	9 10-14 P 490	64479	98
AS-0054	9 10-12 P 488	64459	83
AS-0056	9 10-19 P 470	64338	154
AS-0057	9 10-21 P 448	64383	163
AS-0057-1G	9 10-21 P 448	64383	163
AS-0058	FD 200-19 505	64517	234
AS-0058-1F	FD 200-22 706	64665	239
AS-0058C	FD 200-19 761	75977	236
AS-0059	9 10-16 P 392	64305	112
AS-0061	9 10-19 P 1138	74663	160
AS-0061-1	9 10-16 P 1240	75973	119
AS-0061-1G	9 10-19 P 762	64708	156
AS-0062	9 10-16 P 498	64315	115
AS-0063	11 10.5-24 S 276	70118	212
AS-0068	FD 120-20 715	64666	230
AS-0069	6 6.5-13 S 044	68128	41
AS-0073	11 10.5-15 A 422	64428	189
AS-0075	FT 330-29 434	64285	267
AS-0077	9 10-14 A 312	75626	92
AS-0077	9 10-14 P 312	64274	93
AS-0078	11 10.5C-16 A 378	64357	191
AS-0082	11 10.5-15 A 415	64253	188
AS-0083	9 10-16 A 354	64299	110
AS-0084	9 10-13.5 S 433	64287	89
AS-0086	FT 530-35 441	64580	279
AS-0087	FD 331-26 541	64599	256
AS-0087-1F	FD 331-26 514	64597	256
AS-0088	FD 200-19 510	64519	235
AS-0089-1G	FD 530-35 530	64604	261
AS-0090	9 10-17.5 P 443	64402	130
AS-0092	FD 200-22 529	64558	239
AS-0093	FD 330-22 367	64497	249
AS-0094	10 10-15 S 518	64396	172
AS-0095	9 10-12 A 327	64446	79
AS-0096	9 10D-21 A 324	64375	166
AS-0098	10 10-15 S 713	64639	173
AS-0099	11 10.5-24 S 277	70119	213
AS-0101	9 10-16 P 352	64297	110

MANUFACTURER	CT	No.	2 3
AS-0104	9 10-21 A 505	64716	163
AS-0104	9 10-21 P 505	64384	164
AS-0106	6 6.5D-11 S 034	68115	38
AS-0107-G	10 10-16 S 724	64649	178
AS-0109	FD 331-26 514	64597	256
AS-0110-G	FD 530-35 720	64623	262
AS-0111-G	FD 200-25 721	64622	244
AS-0112	FD 330-30 371	64535	253
AS-0113-G	9 10-16 P 769	64650	117
AS-0115-G	FD 200-25 454	64554	243
AS-0119-F	FD 200-25 427	64550	241
AS-0122-G	FD 200-25 429	64552	242
AS-0123-G	FD 530-30 707	64676	260
AS-0124-F	11 10.5-21 A 318	64352	206
AS-0125-G	9 10-16 P 770	64651	118
AS-0127-G	9 10-18.5 P 519 (BK)	64265	144
AS-0130	9 10-14 P 346	64467	94
AS-0136	FD 330-22 331	64268	246
AS-0137	9 10-21 A 505	64716	163
AS-0137	9 10-21 P 505	64384	164
AS-0139	9 10-18.5 P 521 (BK)	69646	145
AS-0140	9 10-16 P 410	64276	114
AS-0141	9 10-18.5 P 519 (BK)	64265	144
AS-0142	9 10-19 A 358	64327	152
AS-0142	9 10-19 P 358	64615	152
AS-0142	9 10-19 P 383	64281	153
AS-0143	9 9-12 P 401	64362	49
AS-0144	11 10.5F-17.5 P 800	65218	200
AS-0145-1G	FD 200-25 427	64550	241
AS-0146-1G	FD 200-19 713	67705	236
AS-0147-1G	9 10S-16 P 382	67473	121
AS-0149-1G	FS 330-11 474	64596	216
AS-0156-1G	FD 200-19 319	64271	231
AS-0159	11 10.5F-17 P 745	65593	200
AS-0159-1C	11 10.5F-17.5 P 829	65796	201
AS-0159-1G	11 10.5F-17 P 745	65593	200
AS-0164-1G	9 10-17.5 P 548	64412	133
AS-0168-G	FT 330-29 525	64571	269
AS-0171	9 9K-15 P 417	64386	65
AS-0175	10 10-21 P 486	64419	182
AS-0180	11 10.5C-16 A 706	64628	192
AS-0182	9 10S-16 P 382	67473	121
AS-0183	9 10-14 A 545	64486	101

MANUFACTURER	CT	No.	2	3
AS-0186	11 10.5C-16 A 729	64660	193	
AS-0195	9 10-19 P 796	65382	157	
AS-0204	9 10-19 P 814	65520	157	
AS-0208	11 10.5-22 A 824	65772	210	
AS-0218	9 10-16 P 841	66005	118	
AS-0219	10 10-16.5 S 854	66083	180	
AS-0220	11 10.5-21 A 855	66084	207	
AS-0221	11 10.5-22 A 856	66085	211	
AS-0222	FT 530-35 808	67572	283	
AS-0241	11 10.5E-19 S 1320	77833	205	
AS-0246	11 10.5-24 S 1200	75464	213	
<b>ZF</b>				
050121-8174	9 10-14 P 825	65912	103	
50173-6800	11 10.5A-16 P 934	67447	191	

MANUFACTURER	CT	No.	2	3
--------------	----	-----	---	---





## Air Spring Systems

Market segment

Replacement Business

Contact USA

Phone +1(855)90-CONTI  
+1(855)90-26684

Contact Mexico

ContiTech Mexicana S.A. de C.V.  
Av. Industrias 3515, Zona Industrial  
MEX - C.P. 78395 San Luis Potosí  
Phone +52 (444) 826-9412

Your local contact

[www.continental-industry.com/contactlocator](http://www.continental-industry.com/contactlocator)

Website

[www.continental-industry.com](http://www.continental-industry.com)  
[www.airspringreplacement.com](http://www.airspringreplacement.com)  
[www.continental-aftermarket.com](http://www.continental-aftermarket.com)

Online Catalogue

[www.airspringcatalogue.com](http://www.airspringcatalogue.com)

Air Spring App

[www.airspringapp.com](http://www.airspringapp.com)

Certification in the Advanced Dynamics

Solutions business area:

IATF 16949

ISO 9001

ISO 14001



Detailed information about  
our air springs can be found at:  
[www.airspringreplacement.com](http://www.airspringreplacement.com)

## Legal notice

The content of this publication is provided for information only and without responsibility. ContiTech AG's obligations and responsibilities regarding its products are governed solely by the agreements under which the products are sold. Unless otherwise agreed in writing, the information contained herein does not become part of these agreements. This publication does not contain any guarantee or agreed quality of ContiTech AG's products or any warranty of merchantability, fitness for a particular purpose and non-infringement. ContiTech AG may make changes in the products or services described at any time without notice. This publication is provided on an "as is" basis. To the extent permitted by law, ContiTech AG makes no warranty, express or implied, and assumes no liability in connection with the use of the information contained in this publication. ContiTech AG is not liable for any direct, indirect, incidental, consequential or punitive damages arising out of the use of this publication. Information contained herein is not intended to announce product availability anywhere in the world.

© 2022 ContiTech AG. All rights reserved. For complete information go to: [www.continental-industry.com/disclosure](http://www.continental-industry.com/disclosure)