



## One Stop: Multi-V Belt Kit





We have developed the new ContiTech Multi-V Belt Kits for every aftermarket mechanic for whom efficiency and reliability are important. They are suitable for 565 vehicle models from 24 manufacturers covering almost 4500 different applications. This means they cover the most popular vehicles on the European market.



#### Augmented Reality

Graphics with this symbol provide additional content like 3D-illustrations or animations that can be displayed on your smartphone or tablet PC. Just install the free ContiDrive App or the Junaio App and scan the graphic to get the augmented contents.

Available for iOS and Android.

# Full control of tension:

## Multi-V Belt Kit

After changing a multi V-belt, long-term trouble-free running is only assured if the belt tension is correct. It therefore makes sense to also replace all the wear parts in the belt drive, e.g. tensioning and idler pulleys or dampers, whenever a belt is changed.

ContiTech's Multi-V Belt Kit ensures that fitters immediately have all the necessary components at hand - optimally matched to each other and ready for immediate use. That makes the belt change simpler and faster. Furthermore, because all the components come from a single source, there is also just one

point of contact for all service queries. That makes operations in the workshop more economical and efficient. In addition, workshops are fitting original equipment quality when they use ContiTech components.

You can rely on it, and your customers also appreciate it: Multi-V Belts from ContiTech are generally not ground, but manufactured in a molding process. That ensures optimal dimensional precision, long service lives and smooth running. The quality of the components can also be seen in the detail, for instance in the deep groove ball bearings used.

These long-life bearings are fitted with an enlarged grease reservoir and deliver outstanding performance because of their high load ratings. They therefore work particularly reliably and quietly.

### Contents

- > Multi-V Belt
- > Tensioning and idler Pulleys
- > Tensioning Dampers
- > Fixing Material

### Benefits

- > Precise allocation to specific vehicles
- > Perfectly matched components
- > Original quality

#### Baseplate (mounting flange)

Made of die-cast aluminum

#### Sliding bearing

Enables rotation of the tensioning arm

#### Friction lining

With steel friction ring (outer)

#### Torsion spring

Generates pretensioning

#### Tensioning pulley

With single-row bearings

#### Tensioning arm

Made of die-cast aluminum

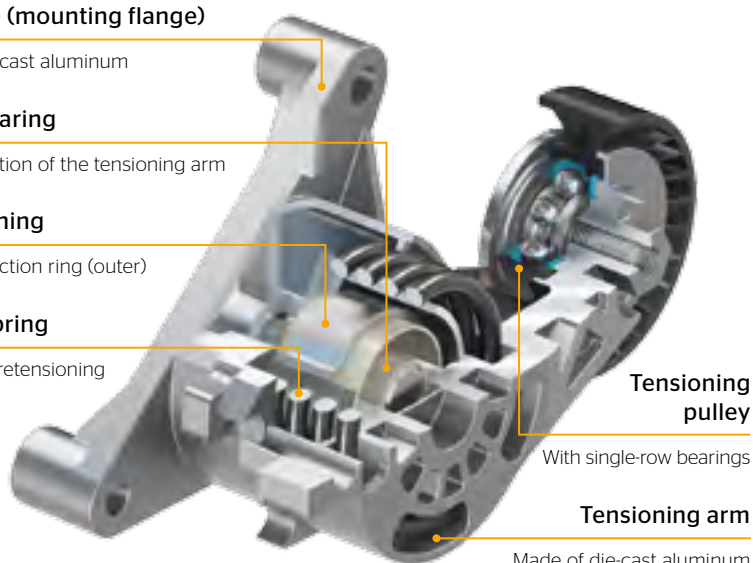

# Product range

## Multi-V Belt Kit

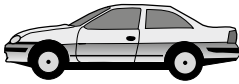
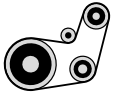

4PK		
4PK735K1	Ford Mondeo / Transit 2.0 bis 2.2 Di, TDCi, TDDi; Jaguar X-Type 2.0 bis 2.2 D	2000-2009
4PK855K1	Audi A4 / A6; VW Passat; Škoda Superb 1.6, 1.8 (T), 1.9 TDI, 2.0 (TDI)	1994-2008
4PK890K1	BMW 3 316 i, g, 318 i, is, g, ti / 5 518 i, g / Z3 1.8, 1.9	1991-2003
4PK925K1	Dacia Logan / Sandero; Renault Clio / Kangoo / Thalia / Twingo 1.2 (LPG) (16V)	1997-2008
5PK		
5PK940K1	Opel Astra G, H / Combo / Corsa / Meriva / Vectra C / Zafira A, B 1.6 (16V) (CNG), 1.8 (16V)	1998-
5PK1125K1	Nissan Primastar dCi, 2.0; Opel Vivaro 1.9 DI, DTI, 2.0 16V, ECOTEC; Renault Laguna / Trafic 1.9 dCi, 2.0 (16V)	2000-2006
5PK1145K1	Rover 25 / 45 / 200 / 400 1.4 bis 1.8 (16V); Fiat Bravo / Doblo / Punto 1.2 (LPG) 1.4 (Natural Power) (16V); Lancia Ypsilon 1.2, 1.4	2003-2012
5PK1150K1	Alfa Giulietta / Mito 1.4 (TB) (16V); Fiat 500 / Panda / Punto / Doblo 1.2 (LPG) 1.4 (Natural Power) (16V)	2003-
5PK1200K1	Nissan Almera / Micra / Kubistar 1.5 dCi; Renault Clio / Kangoo / Megane / Modus / Scénic 1.4 (16V), 1.6 (16V), 1.5 dCi	2000-
5PK1212K1	Opel Astra G, H / Combo / Corsa / Meriva / Tigra / Zafira A, B 1.6 (16V) (CNG), 1.8 (16V)	1998-
5PK1300K1	Audi A4 / A6; Škoda Superb; VW Passat 1.6, 1.8 (T), 1.9 TDI, 2.0 (TDI)	1994-2008
5PK1432K1	Audi A4 / A6; Škoda Superb; VW Golf / Passat 1.9 / 2.0 TDI	1998-2008
5PK1592K1	Audi A4 / A6; VW Passat 1.9 TDI	1995-2001
5PK1750K1	Dacia Logan / Sandero; Renault Clio / Kangoo / Laguna / Megane / Scénic 1.4 bis 2.0 (16V)	1996-
6PK / 6DPK		
6PK905 EXTRA K1	Citroën Berlingo / C3 / C4 / C5 / DS3 / DS4 / DS5; Mini Mini; Peugeot 2008 / 207 / 208 / 3008 / 308 1.4 (LPG) (16V), 1.6 (Vti) (THP) (16V) (GTI)	2006-
6PK906K1	Audi A3; Seat Cordoba / Ibiza / Inca / Leon / Toledo; Škoda Octavia; VW Bora / Caddy / Golf / New Beetle / Polo 1.9 TDI, SDI	1995-2006
6PK906K3	Audi A3; Seat Cordoba / Ibiza / Leon / Toledo; Škoda Octavia; VW Bora / Golf / Polo 1.9 D, TDI, SDI	1993-2006
6PK976K1	Citroën Berlingo / C3 / C4 / C5 / DS3 / DS4; Peugeot 1007 / 2008 / 206 (+) / 207 / 208 / 3008 / 308 / 407 / 5008 / 508 / Partner 1.4 / 1.6 16V, HDI	2002-
6PK976K2	Ford Fiesta / Focus / Fusion 1.4 / 1.5 / 1.6 TDCi; Mazda 3 1.4 / 1.6 MZ, DI, MZR; Peugeot 307; Citroën C3 / C4 1.4 / 1.6 HDI, 16V; Volvo 1.6 D	2001-
6PK976K3	Seat Cordoba / Ibiza; VW Corrado / Golf / Passat / Sharan / Vento 1.6, 1.8 (i) (16V), 2.0 (i)	1988-2002
6PK995K1	Audi A2; Seat Cordoba / Ibiza / Fabia / Roomster; VW Fox / Lupo / Polo 1.2 / 1.4 TDI	1999-
6PK1045K1	Seat Cordoba / Ibiza; VW Caddy / Golf / Passat / Polo / Transporter / Vento 1.9 D, TD, TDI, GTD, SDI	1990-2003
6PK1045K2	Audi A3; Seat Altea / Leon / Toledo; Škoda Octavia; VW Caddy / Golf / Passat / Touran / Jetta 1.6 / 2.0 FSI	2003-

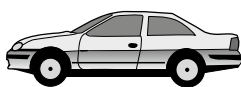

6PK1045K3	Citroën Berlingo / Jumpy / Xsara; Peugeot 306 / Expert / Partner 1.9 D	1996-
6PK1050K1	Audi A3; Seat Altea / Leon / Toledo; Škoda Octavia / Superb; VW Caddy / Golf / Passat / Touran / Jetta 1.9 TDI, 2.0 TDI, SDI	1995-
6PK1050K2	Audi A3; Seat Altea / Leon / Toledo; Škoda Octavia / Superb; VW Caddy / Golf / Passat / Touran / Jetta 1.9 TDI, 2.0 TDI, 16V	2003-
6PK1050K3	Citroën C2 / C3 / C4; Peugeot 1007 / 207 / 307 1.1, 1.4 (i) (16V) 1.6 (VTS) (16V)	2000-
6PK1070K1	Audi A1 / A(Q)3; Seat Altea / Ibiza; Škoda Fabia / Octavia / Superb; VW Caddy / Golf / Passat / Sharan / Tiguan / Touran 1.2 / 1.6 / 2.0 TDI	2003-
6PK1070K2	Seat Arosa / Cordoba / Ibiza / Inca; Škoda Felicia; VW Caddy / Golf / Lupo / Polo / Vento 1.0 (i), 1.4 (i) (16V), 1.6 (i) (GLX)	1991-2005
6PK1070K3	Citroën C2 / C3 / C4; Peugeot 1007 / 207 / 307 / 308 1.4 16V, 1.6 (BioFlex) (16V)	2000-
6PK1080K1	Audi A2; Seat Cordoba / Ibiza / Leon; Škoda Fabia / Felicia / Octavia; VW Bora / Caddy / Golf / Polo 1.4 (16V) (FSI), 1.6 (FSI) (16V) (GLX)	1995-
6PK1080K2	Citroën Berlingo / Evasion / Xantia / Xsara / ZX; Fiat Ulysse; Peugeot 306 / 405 / 406 / 806 / Expert 1.8 (i) (16V), 2.0 (i) (16V) (Turbo)	1991-
6PK1100K1	Seat Altea / Ibiza / Leon / Toledo; Škoda Octavia; VW Caddy / Golf 1.4 (16V), 1.6 (i)	1993-
6PK1125K1	Citroën C2 / C3; Peugeot 307 1.1 (i), 1.4 (i) (16V), 1.6 (16V)	2000-
6PK1145K1	Ford Galaxy; Seat Alhambra / Cordoba / Ibiza / Inca / Toledo; VW Caddy / Golf / Passat / Polo / Sharan / Vento 1.9 D, TD, TDI, SDI	1991-2004
6PK1145K2	Citroën Jumper; ZX; Fiat Ducato; Peugeot 306 / 405 / Boxer; Suzuki Vitara 1.8 D, 1.9 D, TD, DT	1991-2002
6PK1145K3	Peugeot 307 1.4 (16V), 1.6 16V	2000-
6PK1153K1	Seat Alhambra / Cordoba / Ibiza / Toledo; VW Caddy / Golf / Passat / Polo / Vento / Sharan 1.6 (i), 1.8, 2.0 (i) (16V)	1990-2002
6PK1153K2	Peugeot 307 2.0 HDI	2000-
6PK1180K1	Alfa Mito 1.3 JTDM; Fiat Punto 1.3 D; Opel Agila / Astra / Combo / Corsa / Meriva; Suzuki Ignis / Splash / Swift / 1.3 CDTI (16V), DDIS	2003-
6PK1180K2	Seat Cordoba / Ibiza; Škoda Fabia / Roomster; VW Polo 1.4 TDI, 1.9 TDI	2000-
6PK1180K3	Alfa Mito 1.3 JTDM; Fiat 500 / Doblo / Fiorino / Idea / Panda / Punto; Lancia Musa / Ypsilon; Opel Agila 1.3 JTD, D Multijet, CDTI	2003-
6DPK1195K1	Audi A3 / TT; Seat Cordoba / Leon; Škoda Octavia; VW Bora / Golf / New Beetle / Transporter 1.6 (i), 1.8 (T), 2.0	1995-2010
6DPK1195K2	Audi A3; Ford Galaxy; Seat Alhambra / Leon; Škoda Octavia; VW Bora / Golf / Sharan / Multivan / Transporter 1.9 TDI	1995-2010
6PK1200K1	Dacia Duster / Logan / Sandero; Nissan Kubistar / NV200; Renault Clio / (Grand) Scénic / Kangoo / Megane / Modus 1.5 dCi, 1.6 16V	2001-
6PK1200K2	Dacia Logan; Renault Clio / (Grand) Scénic / Kangoo / Megane / Modus / Thalia / Twingo; Nissan Micra 1.4, 1.5 dCi, 1.6 16V	2001-
6PK1217K1	Citroën C4 / C5 / Jumpy; Fiat Scudo / Ulysse; Ford C-Max / Focus / Kuga; Peugeot 307 / 308 / 407 / 508 / Expert 2.0 HDI; Volvo 2.0 D	2003-
6PK1310K1	Fiat 500 / Doblo / Idea / Panda / Punto / Strada; Lancia Musa / Ypsilon 1.3 D Multijet, JTD (16V)	2003-
6PK1370K1	Opel Astra H / Zafira B 1.9 CDTI (16V)	2004-

# Product range

## Multi-V Belt Kit

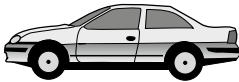

6PK1440K1	Citroën Berlingo / Jumpy / Xsara; Fiat Scudo; Peugeot 306 / Expert / Partner 1.9 D	1996-
6PK1453K1	Citroën Berlingo / Xsara; Peugeot 206 (+) / Partner 1.1(i), 1.4 (i) (BiFuel) (bivalent), 1.6 i, 16V	1996-
6PK1453K2	Seat Cordoba / Ibiza / Toledo; Škoda Fabia / Rapid / Roomster; VW Fox, Polo 1.2 (12V)	2001-
6PK1538K1	BMW 3 320 i, 323 i, 325 xi, 328 i, 330 i, 330 xi, 320 Ci, 323Ci, 325 Ci, 325 ti / 5 520 i, 523 i, 525 i, 528 i, 530 i / 7 728 i, iL / Z3 2.0, 2.2, 2.8, 3.0	1995-
6PK1538K2	BMW 3 320 i, 325 i, 325 xi, 328 i, 330 i, 330 xi, 320 Ci, 323Ci, 325 Ci, 328 Ci, 330 Ci, 325 ti / 5 520 i, 523 i, 525 i, 528 i, 530 i / 7 728 i, iL / X5 3.0 i	1995-
6PK1548K1	Seat Leon / Toledo; Škoda Octavia; VW Bora / Golf 1.4 16V, 1.6 (16V)	1996-2010
6PK1555K1	BMW 3 320 i, 323 i, 328 i, 323 ti, 323 i, 325 i / 5 520 i, 523 i, 525 i, 525 iX, 528 i / 7 728 i, iL / Z3 2.8	1889-2001
6PK1555K2	BMW 3 320 i, 323 i, 328 i, 323 ti, 323 i, 325 i / 5 520 i, 523 i, 525 i, 525 iX, 528 i / 7 728 i, iL / Z3 2.8	1889-2001
6PK1555K3	Ford Escort 1.6 16V, i, 1.8 16V	1995-2000
6PK1560K1	Citroën Berlingo / Xsara; Peugeot 206 / Partner 1.1 (i), 1.4 (i) (bivalent), 1.6 (16V)	1996-
6PK1564K1	Citroën Berlingo / Nemo / Xsara; Fiat Fiorino / Qubo; Peugeot 206 / Bipper / Partner 1.1 (i), 1.4 (i) (bivalent) (BiFuel), 1.6 16V	1996-
6PK1564K2	Citroën Xsara; Peugeot 206 1.1 (i), 1.4 i, 1.6 (16V)	1997-
6PK1613K1	Audi A4; VW Crafter 1.9 TDI, 2.0 TDI (16V)	2000-
6PK1642K1	Renault Espace / Laguna / Megane / Scénic 1.9 dTi, 1.9 dCi, 1.9 D, 1.9 dT; Volvo S40 / V40 1.9 DI, TD	1995-2003
6PK1642K2	Ford Mondeo / Transit 2.0 - 2.2 Di, TDCi, TDDi; Jaguar X-Type 2.0 - 2.2 D	2000-2009
6PK1660K1	Audi A3; Seat Cordoba / Ibiza / Leon / Toledo; Škoda Octavia; VW Bora / Caddy / Golf / New Beetle / Polo 1.9 TDI, SDI	1995-2010
6PK1660K2	Audi A3; Seat Cordoba / Ibiza / Leon / Toledo; Škoda Octavia; VW Bora / Golf / Polo 1.9 D, TDI, SDI	1993-2010
6PK1660K3	Renault Espace / Laguna / Megane 1.8, 2.0 (i)	1993-2003
6PK1660K4	Citroën Berlingo / Xantia / Xsara / ZX; Peugeot 306 / 406 1.8 16V, i	1995-
6PK1705K2	Citroën Berlingo / C5 / Xsara; Ford Fiesta / Fusion; Mazda 2; Peugeot 206 / 407 1.4 TDCi, Hdi, CD, 1.6 HDi	2001-
6PK1710K1	Citroën Berlingo / C5 / Nemo / Xsara; Peugeot 206 (+) / 407 / Bipper / Partner 1.4 Hdi, 1.6 Hdi	2001-
6PK1715K1	Ford Focus / Tourneo / Transit 1.8 DI, TDCi	1998-
6PK1725K1	Opel Astra / Calibra / Frontera / Omega / Sintra / Vectra 1.6 (i), 1.8 i, 16 V, 2.0 i, 16V	1988-
6PK1733K1	Audi A1 / A3; Seat Altea / Ibiza / Leon; Škoda Octavia / Superb; VW Golf / Jetta / Passat / Polo / Scirocco / Tiguan 1.4 TSI, TFSI, 1.6 LPG	2007-
6PK1733K2	BMW 3 316 i, 316 g, 318 i, 318 is, 318 ti / Z3 1.8, 1.9	1993-2000
6PK1733K3	Audi A3; Seat Cordoba / Ibiza; Škoda Fabia / Octavia / Rapid / Roomster; VW Eos / Golf / Passat / Polo / Touran 1.4 FSI 1.6 (16V) (FSI)	2002-
6PK1733K4	Ford Focus 1.4 / 1.6 16V	1998-2004



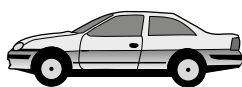

6PK1740K1	Citroën Berlingo / Jumpy / Xsara; Peugeot 206 / 406 / 807 / Expert / Partner 2.0 Hdi (16V); Fiat Scudo / Ulysse; Lancia Phedra 2.0 JTD (16V)	1998-
6PK1740K2	Citroën Berlingo / Evasion / Jumpy / Xsara / ZX; Fiat Scudo / Ulysse; Peugeot 306 / 406 / 806 / Expert / Partner 1.9 D, DT, TD, 2.1 TD	1991-
6PK1740K3	Citroën Xsara / Peugeot 206 2.0 HDi	1999-
6PK1750K1	Citroën Berlingo / C5 / Evasion / Jumpy / Xantia; Peugeot 206 / 306 / 406 / 806 / Partner 2.0 Hdi, 16V; Fiat Ulysse; Lancia Zeta 2.0 JTD, 16V	1998-
6PK1750K2	Renault Clio / Kangoo / Laguna / Megane / Scénic / Thalia 1.4 (16V), 1.6 (16V)	1997-
6PK1750K3	Citroën Berlingo / Jumpy / Xsara; Peugeot 306 / 406 / Expert 1.9 D, DT, 2.1 TD	1996-
6PK1795K1	Mitsubishi Carisma 1.9 DI-D; Opel Movano / Vivaro 1.9 DTI; DI, 2.0 16V; Renault Laguna / Trafic; Nissan Primastar 1.8 16V, 1.9 dCi, 2.0 16V	2000-
6PK1795K2	Mitsubishi Carisma 1.9 DI-D; Opel Movano / Vivaro 1.9 DTI, DI; Renault Laguna / Master / Trafic 1.9 dCi; Volvo S40 / V40 1.9 DI	1999-
6PK1870K1	BMW 1 116 i, 118 i, 120 i / 3 316 i, 318 i, 320 i, 320 si, 316 Ci, 316 ti, 318 Ci, 318 ti / 5 520 i / X1 18 i / X3 2.0 i / Z4 2.0 i	2000-
6PK1873K1	Seat Cordoba / Ibiza / Toledo; Škoda Fabia / Rapid / Roomster; VW Fox, Polo 1.2 (12V)	2001-
6PK1873K3	Opel Astra / Zafira 2.0 DI, DTI, DTI 16V, 2.2 DTI	1998-2005
6PK1873K4	Mercedes C-Klasse / CLK C200 / 230 Kompressor / E-Klasse E200 / 230 Kompressor / SLK 200 / 230 Kompressor	1995-2004
6PK1900K1	Daewoo Leganza / Nubira; Opel Astra / Calibra / Omega / Vectra 1.6 (i), 1.8 i, 16V, 2.0 i, 16V	1988-
6PK2080K1	BMW 3 318 d, 320 d, 330 d, 320 Cd, 330 Cd, 318 td, 320 td, 330 xd / 5 520 d, 525 d, 530 d, 530 xd, 535 d, 525 xd, 530 xd / 7 730 d, Ld / X5 3.0 d	2001-
6PK2260K1	Mercedes C-Klasse C200 / 220 CDI / E-Klasse E200 / 220 / 270 / 280 / 320 CDI / Sprinter 415 CDI / Viano 2.0 / 2.2 CDI / Vito 109 / 111 / 115 CDI	2001-
6PK2271K1	Mercedes C-Klasse C200 CDI / E-Klasse E200 / 220 / 270 / 320 CDI / M-Klasse ML270 CDI / Viano 2.0 / 2.2 CDI / Vito 109 / 111 / 115 CDI	1998-
6PK2404K1	Audi A4 / A6 / A8 / Allroad; Škoda Superb / VW Passat 2.5 TDI	1997-2006

## 7PK

7PK1125K1	Renault (Grand)Scénic / Megane 1.9 dCi, D, 2.0 (Tce) (16V)	2002-
-----------	--	-------





We have developed the new ContiTech Multi-V Belt Kits for every aftermarket mechanic for whom efficiency and reliability are important. They are suitable for 565 vehicle models from 24 manufacturers covering almost 4500 different applications. This means they cover the most popular vehicles on the European market.







More information available in the PIC.

# Parts list

## Multi-V Belt Kit

KIT			
<b>4PK</b>			
4PK735K1	4PK735	V85583	
4PK855K1	4PK855	V85533	
4PK890K1	4PK890	V85535	
4PK925K1	4PK925	V85602	
<b>5PK</b>			
5PK1125K1	5PK1125	V85589	
5PK1145K1	5PK1145	V85569	
5PK1150K1	5PK1150	V85569	
5PK1200K1	5PK1200	V85596	
5PK1212K1	5PK1212	V85547	
5PK1300K1	5PK1300	V85543	
5PK1432K1	5PK1432	V85563	
5PK1592K1	5PK1592	V85571	
5PK1750K1	5PK1750	V85585	V85519
5PK940K1	5PK940	V85547	
<b>6DPK / 6PK</b>			
6DPK1195K1	6DPK1195	V85542	
6DPK1195K2	6DPK1195	V85564	
6PK1045K1	6PK1045	V85567	V85537
6PK1045K2	6PK1045	V85542	
6PK1045K3	6PK1045	V85510	
6PK1050K1	6PK1050	V85578	
6PK1050K2	6PK1050	V85579	
6PK1050K3	6PK1050	V85565	
6PK1070K1	6PK1070	V85576	
6PK1070K2	6PK1070	V85548	
6PK1070K3	6PK1070	V85565	

KIT			
6PK1080K1	6PK1080	V85548	
6PK1080K2	6PK1080	V85509	
6PK1125K1	6PK1125		V85561
6PK1145K1	6PK1145	V85567	V85537
6PK1145K2	6PK1145	V85508	
6PK1145K3	6PK1145		V85561
6PK1153K1	6PK1153	V85541	V85537
6PK1153K2	6PK1153	V85555	V85516
6PK1180K1	6PK1180	V85581	
6PK1180K2	6PK1180	V85576	
6PK1180K3	6PK1180	V85598	
6PK1200K1	6PK1200	V85596	
6PK1200K2	6PK1200	V85596	V85521
6PK1217K1	6PK1217	V85591	
6PK1310K1	6PK1310	V85598	
6PK1370K1	6PK1370	V85599	V85525 V85526
6PK1440K1	6PK1440	V85555	V85500 V85504
6PK1453K1	6PK1453	V85552	
6PK1453K2	6PK1453	V85603	
6PK1538K1	6PK1538	V85546	V85534
6PK1538K2	6PK1538	V85607 V85559	V85534
6PK1548K1	6PK1548	V85562	V85511
6PK1555K1	6PK1555	V85607 V85559	V85534
6PK1555K2	6PK1555	V85546	V85534
6PK1555K3	6PK1555	V85588	V85518
6PK1560K1	6PK1560	V85601	V85520
6PK1564K1	6PK1564	V85601	V85520

KIT			
6PK1564K2	6PK1564	V85557	V85502
6PK1613K1	6PK1613	V85576	V85524
6PK1642K1	6PK1642	V85586	V85507
6PK1642K2	6PK1642	V85568	V85514 V85515
6PK1660K1	6PK1660	V85545	V85538
6PK1660K2	6PK1660	V85572	V85538
6PK1660K3	6PK1660		V85506
6PK1660K4	6PK1660	V85553	V85503
6PK1705K2	6PK1705	V85570	V85505
6PK1710K1	6PK1710	V85587	V85528
6PK1715K1	6PK1715	V85582	V85513
6PK1725K1	6PK1725	V85544	
6PK1733K1	6PK1733	V85600	V85531
6PK1733K2	6PK1733	V85549	V85536
6PK1733K3	6PK1733	V85580	V85531
6PK1733K4	6PK1733	V85560	V85518
6PK1740K1	6PK1740	V85551 V85573	
6PK1740K2	6PK1740	V85551 V85554 V85574	
6PK1740K3	6PK1740	V85573	V85530
6PK1750K1	6PK1750	V85573 V85551	
6PK1750K2	6PK1750	V85585	V85519
6PK1750K3	6PK1750	V85551 V85554 V85574	
6PK1795K1	6PK1795	V85592	V85512
6PK1795K2	6PK1795	V85592	V85519
6PK1870K1	6PK1870	V85597	V85529

KIT			
6PK1873K1	6PK1873	V85603	V85523
6PK1873K3	6PK1873	V85558	V85522
6PK1873K4	6PK1873	V85550 V85517 V85605	
6PK1900K1	6PK1900	V85544	
6PK2080K1	6PK2080	V85593 V85594	V85527
6PK2260K1	6PK2260	V85575	V85540
6PK2271K1	6PK2271	V85575	V85540
6PK2404K1	6PK2404	V85532 V85606	V85539 V85540
6PK905 EXTRA K1	6PK906	V85604	
6PK906K1	6PK906	V85545	
6PK906K3	6PK906	V85572	
6PK976K1	6PK976	V85595	
6PK976K2	6PK976	V85566	
6PK976K3	6PK976	V85541	V85537
6PK995K1	6PK995	V85590	
<b>7PK</b>			
7PK1125K1	7PK1125	V85577	

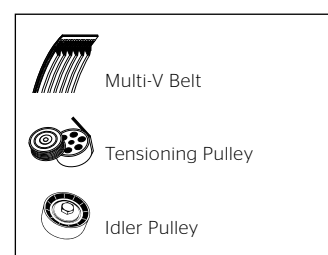

# ContiTech

## Power Transmission Group

Market segment

Automotive Aftermarket

Contact

ContiTech Antriebssysteme GmbH

Hanover, Germany

Tech. Hotline +49 (0)511 938 - 5178

aam@ptg.contitech.de

Your local contact

[www.contitech.de/contactlocator](http://www.contitech.de/contactlocator)



Data, instructions and other technical information available from the PIC at [www.contitech.de/pic](http://www.contitech.de/pic) or simply scan the QR code.

Certified in accordance with



## ContiTech. Engineering Next Level

As a division of the Continental Group, ContiTech is a recognised innovation and technology leader in natural rubber and plastics. As an industry partner with a firm future ahead of us, we engineer solutions both with and for our customers around the world. Our bespoke solutions are specially tailored to meet the needs of the market. With extensive expertise in materials and processes, we are able to develop cutting-edge technologies while ensuring we make responsible use of resources. We are quick to respond to important technological trends, such as function integration, lightweight engineering and the reduction of complexity, and offer a range of relevant products and services. That way, when you need us, you'll find we're already there.